



# CI Series

## Collaborative Intercom System System Planning Guide

### BENEFITS

- Fully Configurable
- Full Duplex, Hands-free Audio
- Universal Microphone Inputs
- Built In Phantom Power
- Built In Equalization
- Automatic Level Control
- Background Music Ducking
- 25 Volt Audio Power Amplifiers
- Vox or Push To Talk Operation
- Broadcast Quality Balanced Line In/Out for Interface to Teleconferencing

The **CI Series** is the most full-featured, flexible communications system available anywhere, at any price. Designed for the most demanding environments, CI Series systems can be custom configured to fit any space. Easy to install, easy to configure, easy to integrate, the CI SERIES' modular design makes system design a breeze. The modular design enables you to custom configure the best system for the job. Select components you need, locate them where they need to be, and put them together via fast, dependable CAT6 connectivity.

The Tech Works **CI-Series Collaborative Intercom** system includes Microphones, Speakers, the CI-MSI-22 Microphone Speaker Interface control unit, Wireless Headsets, the CI-HSI-41 Headset Interface unit, the CI-ODC-1-B Operator Desk Console, and many more accessories like foot operated switches.

The system is based on a sophisticated Automatic Level Control technology which delivers consistent, crystal clear, intelligible sound, from a whisper to a shout. With easy integration to third party headsets, microphones, and speakers, there is almost no limit to how you configure your system;

### Associated Equipment

<b>CI-HSI-41</b>	Headset Interface
<b>CI-MSI-22</b>	Microphone / Speaker Interface
<b>CI-ODC-1-B</b>	Operator Desk Console
<b>CI-ODC-4</b>	4 Group Operator Desk Console
<b>PS-2437B</b>	24VDC Power Supply

### Design Information

**Power** 24V DC  
**Wiring** CAT6 Patch Cables



# Tech Works®

"Making Specialized Communication Easy"

# How to use this Manual

Those wishing to use one of the standard Configuration Templates should first read the *Overview*, and then proceed to the appropriate Configuration Template for your application. The *Setup*, *Adjustments* section should also be read before installation.

For those users who wish to do their own engineering, all sections may be useful. You may also wish to contact a Tech Works application engineer for assistance, feel free, we're here for you.

## **Table of Contents**

	Page
CI-BUSS Components	4
Basic System Overview	10
CI-BUSS Connection	11
PA-BUSS Connection	13
Selective Monitoring	14
Ducking	15
Automatic Level Control, ALC	17
Audio System Setup	18
CI-HSI-41 – Headset Interface	5 & 20
CI-MSI-22 – Microphone Speaker Interface	5 & 24
CI-ODC-1-B – Operator Desk Console	4 & 28
CI-ODC-4 – Operator Desk Console	4 & 32
Typical System Wiring Diagram	36
Packaging and Mechanical	39
Best Practices & FAQs	40

## Figures

CI-ODC-1-B Operator Desk Console	4 & 29
CI-ODC-4 Operator Desk Console	4 & 33
CI-HSI-41 Headset Interface	5 & 20
CI-MSI-22 Microphone Speaker Interface	5 & 24
FS-ODC - Operator Foot Switch	6
FS-1-PLUS – Procedure Room Foot Switch	6
SAVI 7210 - Single-Muff, Noise Cancelling Headset	6
SAVI 7220 - Dual-Muff, Noise Cancelling Headset	6
PRO-SGM - Shotgun Microphone Assembly	7
HM-1 Omni-Directional Hidden Microphone	7
CRS-RC – Clean Room Round Ceiling Mount Speaker	7
CRS-WM – Clean Room Wall Mount Speaker	7
PA-402 Paging and Program Amplifier	8
PA-SI-1 Paging and Program Speaker Interface	8
PMI-B - Portable Music Interface	8
CAT6-BB - RJ-45 Cable Breakout Board	9
CAT6-* Patch Cord	9
PS-2437B - 24VDC @3.7A Power Supply	9
PC-* Power Patch Cable	9
CI-BUSS Connector	11
System Functional Block Diagram	12
PA-BUSS Connector	13
PA-BUSS Chain	13
Selective Gain Reduction, “Ducking”	15
Master Slave Connection Diagram	16 & 39
Automatic Level Control, ALC	17
Typical System Wiring Diagram	36-38
Packaging and Mechanical	39
CI-BUSS Crossover wiring	40

# CI-BUSS Collaborative Intercom Components

## CI-ODC-1-B – Operator Desk Console



The Tech Works CI-ODC-1-B Operator Desk Console includes a professional cardioid, condenser, gooseneck microphone, and a speaker. Buttons and indicators provide control to allow the operator to just listen to the CI-Buss communication or to talk, and collaborate hands free. A headset jack on the side of the console allows connection of a local operator headset such as the CS-540 wireless unit.

Setup is plug and play with an integral speaker level control to adjust the listening level. No further adjustments should be required for standard operation. Integral VOX and ALC allow for full duplex conversations without feedback.

Internal, installer settable, jumper options allow the functionality of the CI-ODC-1 to be Hands-Free or Push-To-Talk. The Push-To-Talk button can be either latching (Push On, Push Off) or momentary, meaning the microphone is active as long as the operator holds the button down.

The CI-ODC-1 is a CI-BUSS Master device designed to control other units or functional blocks in a system. If there is a device in the system that has a “Call” input, like the CI-MSI-22, when a contact closure on the Call input sends a Buss Call signal the CI-ODC-1 will emit a tone sequence to let the Operator know that someone is trying to get their attention.

## CI-ODC-4 – Operator Desk Console



The CI-ODC-4 allows a single operator location to communicate selectively with up to 4 separate systems in 4 separate rooms. It includes a professional cardioid, condenser, gooseneck microphone, and a speaker. Buttons and indicators provide control to allow the operator to just listen to the CI-Buss communication or to talk, and collaborate hands free. A headset jack on the side of the console allows connection of a local operator headset such as the CS-540 wireless unit.

Setup is plug and play with an integral speaker level control to adjust the listening level. No further adjustments should be required for standard operation. Integral VOX and ALC allow for full duplex conversations

without feedback.

The CI-ODC-4 can be used in a small Intercom when connected to a single CI-Buss product or as an addition to larger systems using microphones, speakers. The CI-ODC-4 can also function as an audio combiner to allow multiple rooms to collaborate.

Internal, installer settable, jumper options allow the functionality of the CI-ODC-4 to be Hands-Free or Push-To-Talk. The Push-To-Talk button can be either latching (Push On, Push Off) or momentary, meaning the microphone is active as long as the operator holds the button down.

The CI-ODC-4 is a CI-BUSS Master device designed to control other units or functional blocks in a system. If there is a device in the system that has a “Call” input, like the CI-MSI-22, when a contact closure on the Call input sends a buss Call signal the CI-ODC-4 will emit a tone sequence to let the Operator know which room is trying to get their attention.

## CI-HSI-41 – Headset Interface



The Tech Works CI-HSI-41 Headset Combiner is designed to take standard Plantronics headsets and let them talk to each other as well as other Tech Works CI-Buss products. The CI-HSI-41 accommodates up to four Plantronics CS-540 lightweight, Wireless Headsets. The headsets communicate with each other, as a single headset with four summed microphones.

The Intercom can simply plug together using standard CAT-6 patch cables. When connected to another unit all headsets become part of that system. Two CI-HIS-41 can be connected together to make a single system of up to 8 headsets. The eight headsets act as one unit.

Initial setup is accomplished with built in level indicator lights and the controls on the receiver/charging base. Once completed, no further adjustments should be required.

The CI-HSI-41 can be used as a small stand-alone Wireless Headset Intercom or as an addition to systems using microphones, speakers, and other CI-Buss and PA-Buss devices. By adding a PA-402 the headset conversation can be played over ceiling speakers so observers can hear the conversation.

## CI-MSI-22 – Microphone Speaker Interface



The CI-MSI-22 consists of five Functional Modules; Two Inputs; The local Microphone/Line Input and the PA-BUSS Input, Two Outputs; a 25 Volt Speaker Output and the PA-BUSS Output, and the CI-BUSS Interface. The Jumper Options determine how these Modules interact and function with each other. The "Standard Configuration" is a Remote (Single Location) for use with an Operator Console. The Power Amplifier, is used for a Procedure Room Speaker while the Microphone Input is used for a boom mounted or hanging Procedure Room Microphone. The PA-OUT, is used as Procedure Room Monitor Output, perhaps for Background Music. The PA-IN, may be used for an additional Microphone. The CI-BUSS, may be used with other Interfaces, such as a CI-HSI-41 to include Headsets.

Initial setup is accomplished with built in level indicator lights and the controls. Once completed, no further adjustments should be required. Integral ALC, Variable Notch Filters, and Speaker Ducking allow for full duplex conversations without feedback.

### FS-ODC - Operator Foot Switch



The FS-ODC is used in the control room for push-to-talk when hands are busy. Our Foot Switches are ruggedly designed for harsh environments with a rubber non-slip pad and 10-foot rubber jacketed cord. The FS-ODC is used in the control room for push-to-talk when hands are busy.

### FS-1-PLUS – Procedure Room Foot Switch



The FS-1-PLUS is used as a call button in the controlled environment to summon an operator.

### SAVI 7210 - Single-Muff, Noise Cancelling Headset



Mobility is key in controlled environments and our headsets give professionals just that. Using DECT technology, these headsets provide secure two-way communications between the controlled environment and operators. Standard controls on either headset operates features of the CI-Series system such as listen, talk, mic mute, and level. The **SAVI 7210** is a wireless single-muff noise cancelling headset with an adjustable boom microphone.

### SAVI 7220 - Dual-Muff, Noise Cancelling Headset



The **SAVI 7220** is a wireless dual-muff noise cancelling headset with an adjustable boom microphone. The 7220 is identical to the 7210 except that it has the dual ear muff for high noise environments.

## PRO-SGM - Shotgun Microphone Assembly



The **PRO-SGM** is a shotgun microphone assembly which includes a wall plate, jack, cord, and gimble mount, so it easily mounts to a wall or ceiling and can be easily directed toward the audio source. A 6-inch wire pigtail is soldered to the XLR jack so that the field technician can terminate the field wire without providing a soldering iron. Everything you need is included for proper installation.

## HM-1 Omni-Directional Hidden Microphone



Our **HM-1** omni-directional hidden microphone mounts to a simple wall plate and is very effective for observation areas.

We've selected the best and most popular 25V speakers to pair with the products we build. Our speakers are Clean Room Certified for use in low dust and sealed environments.



Tech Works Model CRS-RC is a complete, recessed mount loudspeaker system for hard ceiling applications in clean room environments. Rubber gaskets are included between the baffle mount screws and the baffle, the baffle and backbox, and between the backbox and the ceiling.

The CRS-RC features a moisture resistant washable cone design loudspeaker and includes a factory mounted 25V transformer.



Tech Works Model CRS-WM is a complete cost, effective, wall mounting assembly that includes a high-quality 8" loudspeaker, 25V transformer and perforated steel grill. This unit is made to "Surface Mount" in places with limited access to walls and ceilings in clean room environments. Rubber gaskets are included between the baffle mount screws and the baffle, the baffle and back box, and between the back box and the ceiling. It has an angled sloping front to allow maximum coverage of the listening area.

## PA-402 - Paging/Program Amplifier



The PA-402 is a Professional Audio Power Amplifier designed with the System Integrator in mind. It is specifically designed for Background Music, and Paging Applications and may be used with other Tech Works products to augment a variety of system designs. The PA-402 has Program Audio Inputs, Paging Audio Inputs, and Control signals that select which Audio inputs are directed to the Speaker. These inputs are transformer balanced allowing several PA-402's to be connected in tandem, for large distributed systems. There is also an unbalanced Stereo Input for "Local" Music insertion. The logic allows for a wide range of control requirements including; Enabling, Muting, Program, or Page selection. The PA-402 comes ready to use for most applications, and there are Application Templates for other common uses. The PA-402 is fully protected against overloads. The unit automatically recovers when any overload is removed.

## PA-SI-1 – Speaker Interface



The PA-SI-1 Speaker Interface is a 1-Watt Utility Audio Power Amplifier designed with the System Integrator in mind. The input is transformer balanced allowing several PA-SI-1's to be connected in tandem. Power comes from the PA-BUSS, to simplify wiring. The PA-SI-1 is fully protected against overloads. The unit automatically recovers when any overload is removed. Modular Construction makes the PA-SI-1 ideal for integrated designs. The unit is small; mounting is flexible, and easy, so it is ideal for space conscious requirements. Mounting options include Snap Track or stud mounting. All signals are connectorized for ease of installation.

## PMI-B - Portable Music Interface



The PMI-B is a Portable Music Interface for Bluetooth to connect devices such as cell phones to play music in the procedure room. The PMI is designed to plug directly into to the PA-402.

## CAT6-BB - RJ-45 Cable Breakout Board



The Tech Works CAT6-BB is a RJ-45 Cable Breakout Board designed to take our Tech Works CAT6 cables and make each conductor accessible by a screw terminal and/or assignable by jumpers. These units are designed for the systems integrator and are typically used with our Collaborative Intercom products to allow fast easy installation with custom music systems or telemedicine conferencing equipment. A built in opto-isolator provides a normally open contact closure for controlling music mute on products not provided by Tech Works.

## CAT6-\* Patch Cord (“\*” specify Length in feet; 1, 3, 10, 25, 50)



The Tech Works CAT6-\* (“\*” specify Length) is an EIA 568B standard computer network Patch Cable designed to connect our Tech Works Collaborative Intercom (CI-Buss) and PA-Buss products together. These units are designed for the systems integrator to make installation Plug and Play.

## PS-2437B - 24VDC @3.7A Power Supply



The Tech Works **PS-2437B** is a regulated computer grade power supply capable of providing 3.75 Amps of power at 24-Volts DC to any of our products. A 6-foot removable power cord with a North American standard Edison connector is included along with a metal mounting bracket to allow the unit to be screwed to the wall or under a counter.

## PC-\* Power Patch Cable (“\*” specify Length in feet; 1, 3, 10, 25, 50)



The Tech Works PC-\* (“\*” specify Length) is a Power Patch Cable designed to connect our Tech Works Collaborative Intercom (CI-Buss) and PA-Buss products together. These units are designed for the systems integrator to make installation Plug and Play. 18-gauge power cord is made with 5.5 mm barrel connectors on each end for connecting 24 VDC power from one unit to the next.

## **CI-BUSS Collaborative Intercom Basic System Overview**

The Tech Works **CI-Series Collaborative Intercom** system was designed to allow many standardized components such as professional microphones, speakers, and headsets to Collaborate to create a unique audio communication environment to best suit the particular application. The CI-Series is a modular, expandable solution which gives professionals working in separate rooms and environments the ability to speak to each other, hands free and seamlessly, as if they were in the same room. For professionals working in controlled environments such as Operating Rooms, Cath Labs, or Clean Rooms - sterile, hands free communication is not only essential, but can be critical. Typically, these environments are noisy; full of equipment and hard, reverberant surfaces. The rooms become an acoustical challenge, resulting in unclear and unintelligible communication. The CI-system is based on a sophisticated Automatic Level Control technology which delivers consistent, crystal clear, intelligible sound, from a whisper to a shout.

An operator station can selectively speak with up to 4-different rooms or controlled environments. Inside the controlled environment, there are many speaker and microphone options; from personal headsets to boom mics and ceiling speakers, the CI-Series has a solution for each professional working in your facility. And no one person dictates how the other communicates; customizable flexibility is what makes the CI-Series Collaborative Intercom truly unique.

Tech Works products use two simple Buss structures that support Collaboration Intercoms (CI-BUSS), and Paging Amplifier (PA-BUSS) Signal Distribution. The use of standard busses allows Tech Works products to plug together.

Simple systems may require a single Box; more complex systems may require several boxes.

The Collaboration Intercom Buss, CI-BUSS; has bi-directional Audio pathways for Communications, and Control. Expansion is easy; units daisy-chain together to form Collaborative Groups.

The PA-BUSS supports one direction; Background Music, Paging, Announcement Loops, selective Monitoring/Communications and many other features.

All signals are electrically isolated to perform in the harshest environments, using transformers, Opto-isolators, and floating elements, to eliminate ground loops. Short Circuit Protection ensures units recover from temporary faults. Standard Category-6 wiring and terminations are used for ease of installation.

Audio Signals are low impedance, transformer balanced and "Line Level" to provide maximum isolation from crosstalk, and noise.

Each Product is "configurable", the functional sections are connected with jumpers. Therefore, products may be 'customized' for the application.

The wiring architecture is Master to Slave. So to connect to functional units together all you do is plug the CI-Master of one unit to the CI-Slave of the next unit.

**The CI-BUSS** (Collaboration Buss) is a wired network using CAT6 patch cords that have four signal pairs for bi-directional communication:

“Call”	(Control)	Indicates a Station wants service
“Slave”	(Audio)	Communications
“Master”	(Audio)	Communications
“Alert”	(Control)	Indicates Action is requested

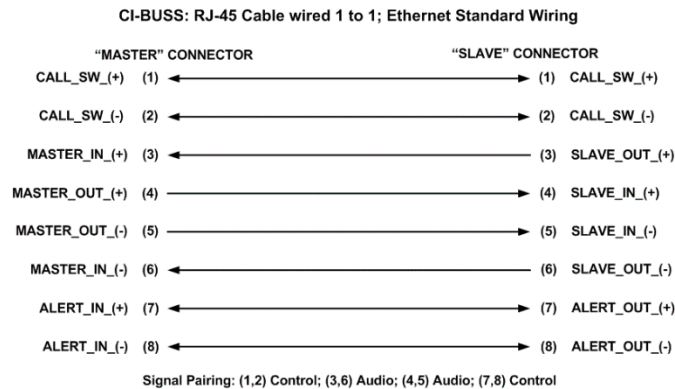

**Typical CI-BUSS Chain:**

The Collaborative Intercom is made up of a collection of functional active modules, each with its own functional design.

The CI-ODC, Operator Desk Console is designed to meet the needs of the Operator.

The CI-MSI, Microphone Speaker Interface is designed to meet the needs of the procedure room microphone and speakers.

The CI-HSI is designed to combine control and process a group of 4 headsets.

By connecting functional modules together, the audio from one can be routed to and shared with other modules to make a custom system.

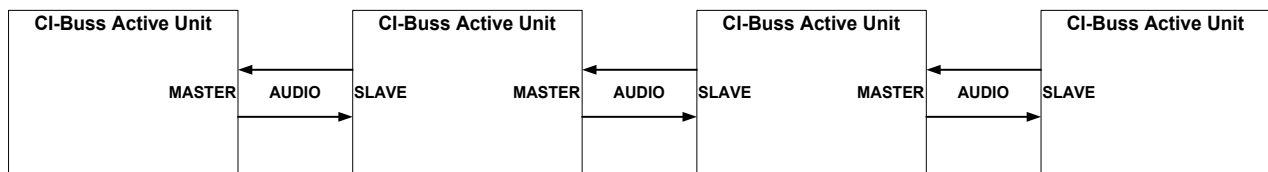

**Functional module units are always connected CI-Master connector to CI-Slave connector**

The signals do not just pass from one unit to another. Each unit has distinct Buss inputs, outputs, and make up gain so that the Buss stays at a consistent audio level. Each unit has Buss option jumpers to select what audio from “this” unit is passed to the next unit.

By arranging the order of the units in the chain and selecting what audio is passed along the installer can determine what each unit “hears”. For instance, if a chain is CI-ODC to CI-MSI to CI-HSI, the MSI jumpers determine if the Operator hears the HSI and if the HSI hears the Operator. If you change the order to ODC to HSI to MSI then the HSI determines who hears each other. If you add a PA-402 Paging and Music amplifier to the system you can plug it into either the MSI or the HSI and get different content listening results as well as different Music Muting.

## CI-BUSS Chain

A CI-BUSS system is made up of a chain of functional blocks of products each designed to do a special job or function.

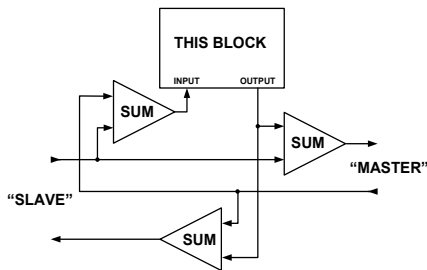

*The Inputs and Outputs, are transformer coupled; omitted here for clarity*

The box marked **"THIS BLOCK"** defines the **function of this Building Block**. A **"BLOCK"** represents a functional component which is a CI part # and may have an **"INPUT"**, or an **"OUTPUT"**, or both.

The SUMers, shown below, are part of every Block, and support the CI SERIES Interface. Each Summer Mixes the Buss Audio signals with the local Audio Signals and Routes them based on the installer configuration.

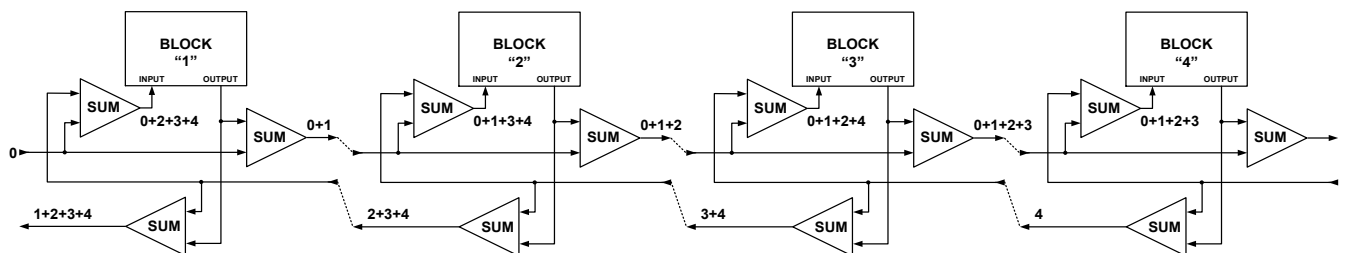

**The Buss structure allows "Blocks" to be "Added" to form a "Chain. A chain is formed by plugging a Master output into a Slave input of another unit.**

Most system requirements are satisfied with a **single "Chain"**, Very large system may have **several "Chains"**, defined as **Groups**, **Groups may be joined together by a Hub**, such as the **CI-ODC-4**

**Jumpers** inside of each unit or Block allow the installer to select what comes in from the BUSS and what goes out to the Buss. Please see the individual Installation Guide for each product for more information about jumper selections and settings of each electronic component.

**Automatic Level Control and Limiting** is used to achieve the standard Output signal levels to keep the sound quality consistent throughout a system.

The **Call Pair** is a **"Party Line"** passing through to all the **Blocks forming a Group**  
 The **Operator Console Responds to a Switch Closure** by initiating a **Calling Sequence**  
 All **Switches must be floating**, or isolated with Opto-Couplers

The **Alert Pair** is a **"Party Line"** passing through to all the **Blocks forming a Group**  
 The **Operator Console sends a signal to all the Other Blocks**, such as *my Microphone is On*  
 The other **Blocks may be configured to "Respond"** in an appropriate manner

**Responder Blocks, are electrically isolated**, with Opto-couplers

A CI-BUSS system is made up of a chain of functional blocks of products each designed to do a special job or function.

The **PA-BUSS** (Audio Distribution Buss) has four signal pairs for one-way communication:

“Buss Power”	(Option) Current Limited, 23-Volts
“Program” (Audio Option)	Background Audio or Music
“Page/Communications” (Audio)	Page/Monitor/Communications Audio
“Alert”	(Control) Indicates Action is Requested

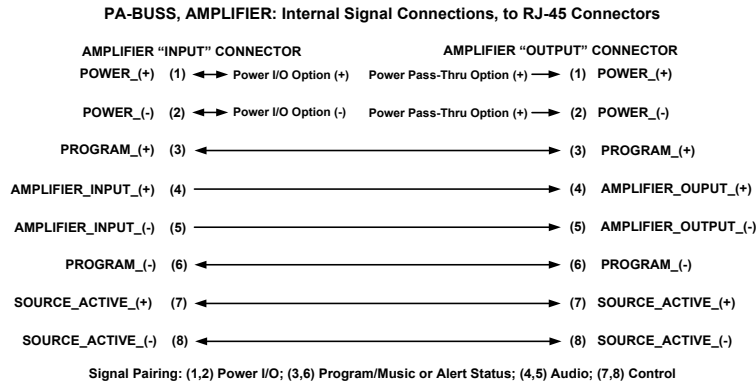

**Typical PA-BUSS Chain:**

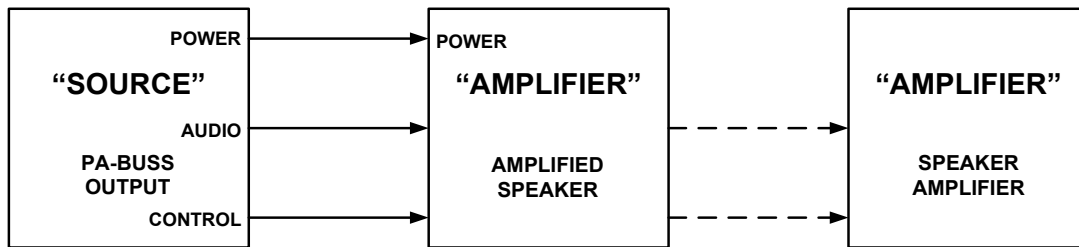

The “Audio Monitoring” may be selectable, adding together the audio sources as desired. A separate Audio pair, "Program" may contain External Music or Program material. “Amplifiers” may respond to an “ALERT” logic signal, by muting Music, and outputting Page/Communications, or other action.

An “Amplifier” is defined as any Unit having a PA-BUSS Input.

Each PA Buss has one "Source", and a "Chain" of "Amplifiers". The Source provides Line Level "Page/Communications" Audio, and Control Signal.

A Power Pair is provided for Amplified Speakers, or Microphone Pre-Amplifiers. The Source and Amplifiers in the "Chain" may share a Power or Control Connection. The Amplifier may supply power to the Source, or The Source may supply power to the Amplifier. *The supply of power is one or the other, or neither, not both (Jumper Options).*

The Audio and Control signal paths are Galvanically Isolated using Transformers and Opto-Couplers. Sources and Amplifiers may be locally bonded to Earth by a metal stud on each chassis.

Tech Works Products have "Line Level" Inputs and Outputs, 0dBm (.775 Volts, RMS).

The Maximum Output of a "Source" is 0dBm, with the "LEVEL" Control set at maximum (Fully CW).

For Tech Works Amplifiers, a 0dBm input corresponds to a Maximum rated Output.

Therefore with all the "LEVEL" controls at Maximum the full rated output is achieved.

However this setting is never used; there should always be some attenuation in the system.

Normally if there are two level controls in tandem, only one is used to set the level, the other is set to maximum (Fully Clockwise).

When an Amplified Speaker is used, the Source PA-BUSS output Level Control is used.

When the PA-BUSS is used with an Amplifier (PA-402), the Amplifier Level Control is used.

In special circumstances with multiple amplifiers, there may be a desire for a "Master" Level Control, with the Individual Amplifier Controls used for Balancing the System.

The Alert Pair is a "Party Line" passing through to all the Units forming an Amplifier Chain.

The PA-BUSS Source is the "Initiator" of the Alert, *other units may take appropriate action.*

Responder Units are electrically isolated, with Opto-couplers.

The ALERT signal requests the Amplifier or Logging Device to take action.

*For example, the amplifier switches from Background Music (Program), to Paging/Communication.*

Tech Works BUSS products are designed to be configured for the application; functional sections are connected with jumpers.

The multitude of configuration possibilities allows a few products to be configured for a myriad of application possibilities! *This design is very flexible; each system is customized for the application!*

If amplifiers are in a chain, configuration *switches* allow different amplifiers to respond as required. *Some Units may ignore the request.*

**Monitoring maybe selective:**

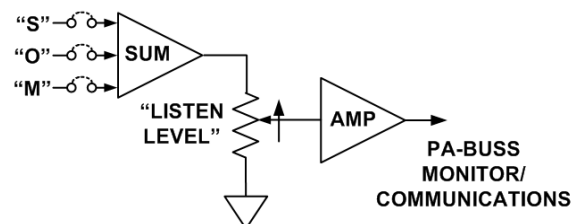
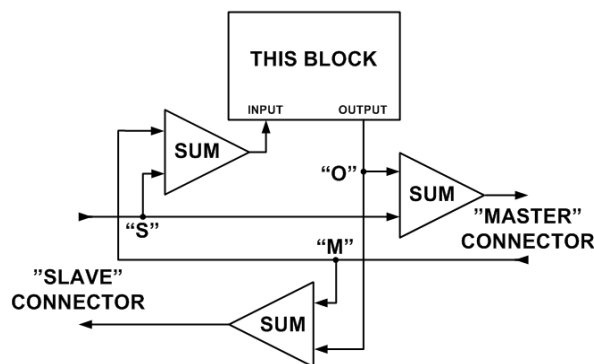

INSERT JUMPERS TO ADD SIGNALS:  
"S" ALL BLOCKS CHAINED TO "SLAVE" CONNECTOR  
"O" THIS BLOCK  
"M" ALL BLOCKS CHAINED TO "MASTER" CONNECTOR

The, Source, /PA-BUSS Output, is the Sum of the appropriate Signal Sources.

Jumper Options select the audio signals on each Block to be output.

*For example, only the "Slave" input, usually the Operator Microphone, may be sent to the output, which is normally the ceiling speaker in the procedure room.*

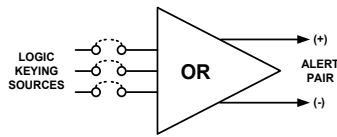

The "ALERT" is a selectable sum (OR) of several keying signals options  
 The Monitor Audio may always be present, or may be Keyed  
 Keyed Audio is useful for Simple Logging/Monitor Devices, Audio is only present when desired

The PA-BUSS, ALERT Signal may be configured to interrupt the "Music" when it's appropriate  
*For example, when the Microphone is active, to avoid music bleeding into the microphone*

**Feedback Prevention:**

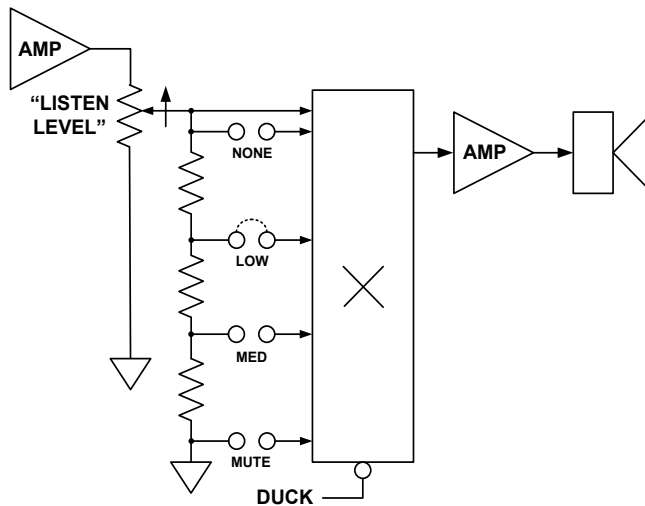

Selective Gain Reduction, "Ducking" is used to determine how much to turn down the sound.

Many intercommunications systems require full Duplex Operation. That is, several users may be listening and talking at the same time. This introduces many acoustic feedback paths  
 When a user enables their microphone, the PA-BUSS, Monitor Speaker may have its output reduced  
 Thus lowering the around the loop feedback gain, and Reducing Feedback

Example: To appreciate the concept, consider the PA-BUSS Output of the MSI-22

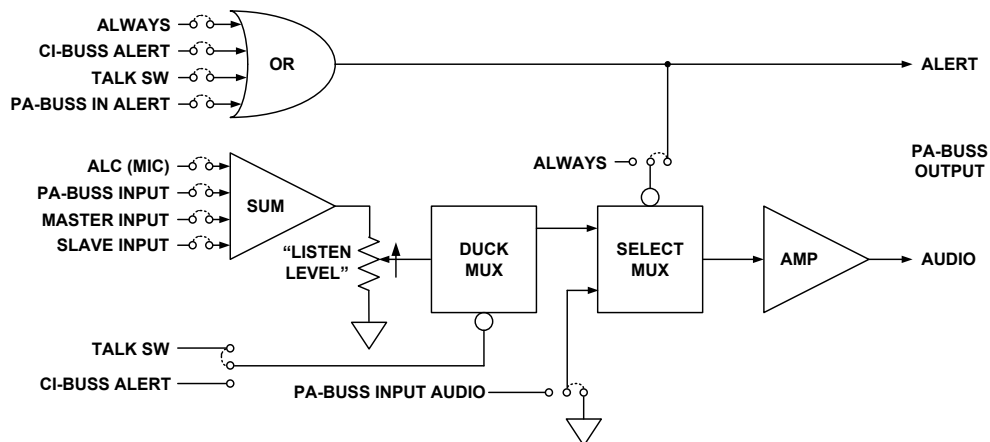

*This is even simplified; "Ducking", Feedback Suppression, also has configuration Jumpers!!!*

The Audio, and Alert Outputs are a function of what the user needs for the application.  
No jumpers; No outputs!!!

Install all of the Audio Source Jumpers, and set the MUX to "Always" and you get everything, all of the time.

Install the Master and Slave Audio Source Jumpers, set the MUX to Always, *perhaps this is a Ceiling Speaker for the "This Room" (Where the Local Microphones are located).*

Install the MIC and PA-BUSS Audio Source Jumpers, set the MUX to Always, *perhaps this is a Ceiling Speaker for the "Operator".*

Install the MIC Audio Source Jumper, Key the MUX with the TALK SWITCH, *the Microphone could be used for Logging or Paging.*

The ALERT control signal indicates a Special Function is required.  
*For example, the PA-402 may respond by replacing Background Music with Communications. Key the ALERT with the CI-BUSS and Talk Switch...the Music goes away if someone is talking!*

There are hundreds of ways to configure the PA-OUTPUT Functional Section, one of five Functional Sections of the MSI-22!!!

And, the MSI-22 may be connected to many other Configurable BUSS products!  
Including another MSI-22!

Simple systems may require a single Box; more complex systems may require several boxes. The Collaboration Intercom Buss, CI-BUSS; has bi-directional Audio pathways for Communications, and Control. While Program/Paging applications are handled by th PA-BUSS for one way Audio Communication and Control.

Expansion is easy; units daisy-chain together to form Collaborative Groups.

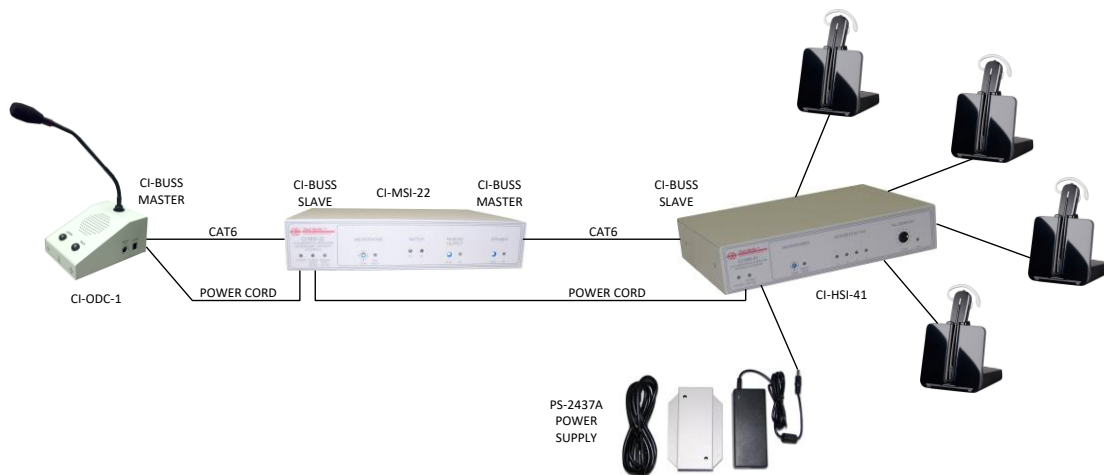

Always connect the Collaborative Intercom active components from Master to Slave on the CI-BUSS.

## Automatic Level Control, ALC:

To allow collaboration, all the users need to have similar Audio Levels  
Even though the signal sources may vary in input level

The CI-BUSS products process the Audio Sources using Automatic Level Control, ALC  
Each Input is adjusted to be approximately 6 dB into limiting, ~ twice the system level  
So the user may talk louder, or if the signal is diminished, the output is not affected

The ALC is associated with the Microphone Gain (Reach) Control (16 Position Rotary Switch)  
A Setup Indicator, Off, if source is muted, Green when the Source is keyed, Flashing Red when limiting

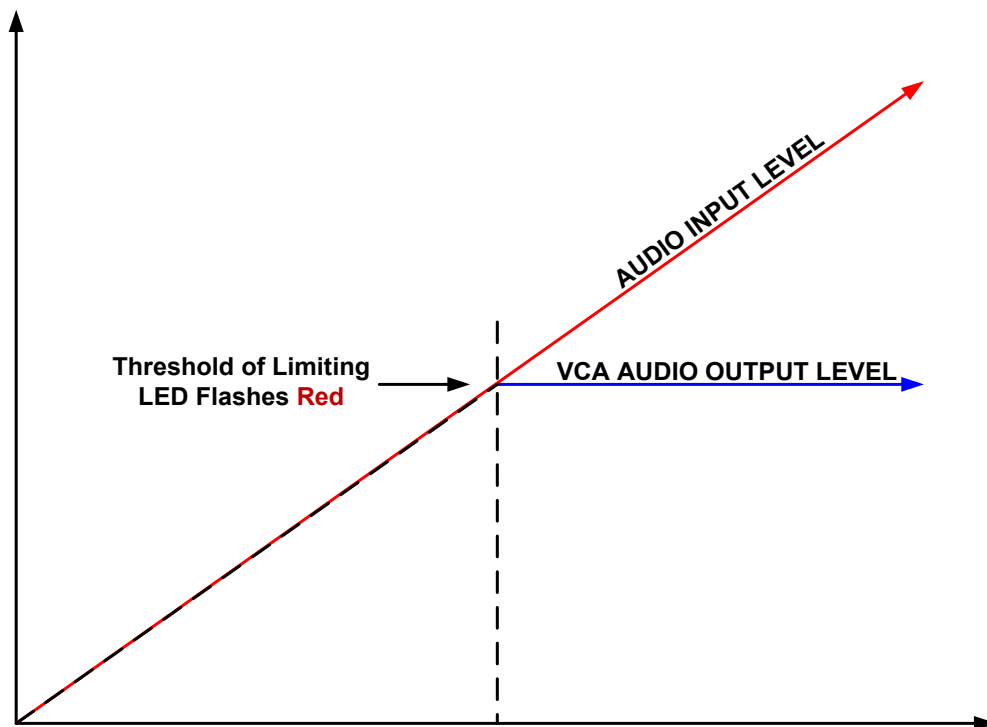

Setup:

The Microphone Gain Control is increased by ~3dB/Step

While an input is present, the Control is advanced CW until the "Threshold of Limiting"

*This establishes the "Normal Input Level"*

Advancing the Microphone Gain CW, increases the gain... *however the Output level remains the same*

For most Applications, two clicks, or ~6db of extra Gain is sufficient

Excessive Gain is not recommended:

The background noise level is increased

The susceptibility to Feedback is increased

## Audio System Setup:

For successful system operation; a methodical approach to system setup is essential. Audio Blocks, must provide gain structures, Controls and Indicators to assure that setup is both simple, and affective.

Below are general setup instructions; for setup details, refer to the Product Sections.

## CI-BUSS Product, Microphone Gain Setup:

Each Block has both Input and Output Controls with associated Indicators.

When the Indicators are green the associated control is active or enabled.

The Audio may be 'Keyed' depending on the system setup.

*Refer to your configuration, and Block User Guides.*

*Do not attempt adjustments if the associated indicator is not lighted green!*

The CI-BUSS uses a standard audio level of ~0dBm RMS.

All audio Blocks have a Digital Rotary Switch (3dB/Step) to set Microphone Sensitivity.

Each Block also includes a fast envelope Limiter, with a "Talk Level" Indicator.

The nominal Microphone gain is ~6dB into limiting, therefore the user has a wide range of inputs, with a nearly constant output levels.

Microphone Gain is always setup first.

Initially, the Output level controls should be set to minimum (No Output).

## Limiter Setup with a Microphone:

*Always do first*

Talk into the microphone at a normal to loud level (don't talk softly).

Insure the Microphone is Keyed, the indicator is Green.

Advance the "Microphone Gain", from "0" until the "Talk Level" indicator just flashes Red.

Advance the "Microphone Gain" another two clicks (6dB into limiting).

Or set the "Microphone Gain" as instructed in that's products user Guide.

## PA-BUSS Output and Speaker setup:

*Assure there is an audio input.*

With normal audio input levels, with Inputs and outputs keyed (Output Indicator Green).

Set the Speaker Listening Level.

See the PA-BUSS Section for Monitor/Communications Output Adjustments.

## PA-BUSS, Audio Level Control Setup:

The PA-BUSS Audio Outputs Levels are dependent on establishing standard CI-BUSS levels.

*CI-BUSS levels must be adjusted, on all system Blocks, first!*

The setup strategy is dependent on the PA-BUSS Amplifier string.

The maximum PA-BUSS audio Signal Output is 0dBm.

All Tech Works Amplifiers, provide maximum rated output with a 0dBm input.

Therefore all controls, on each Block, and Amplifier may be considered an Attenuator (Below the maximum output level).

The setup strategy is also often a matter of convenience. Access to Audio Source Level trim pots is usually easy. Access to Rack mounted Amplifiers is usually easy, but not as convenient as the Source. Access to a Speaker, especially ceiling mounted Speaker, usually is very difficult!

It is recommended, when two (or more) level controls are in tandem, all Controls but the one, used to set the listening level, are at full level (Clock Wise (CW)).

#### Feedback prevention, cautionary measures:

Many Intercom systems require "full duplex" operation; simultaneous communications in all directions

When many microphones, and speakers, are in operation together, many feedback paths exist

The most important feedback prevention technique is speaker Microphone Placement

*The sound level at the microphone from the user, must be much higher than the level from the speakers*

Microphones should be directional, aimed at the user

Speakers should be placed away from the microphones, and out of the pattern of the Microphone

The next most important feedback prevention technique is "Minimum Gain"

Minimum Microphone Gain; place the microphone in close proximity to the User(s)

Users need to 'Speak up' so the gain settings can be reduced

Minimum Speaker levels to accomplish reliable communications

The number of 'Open Microphones' should be kept to a minimum

When possible Microphones should be keyed; *Foot Switches*

And only enabled when the user needs to talk

This also reduces the background noise; making it easier for the listener to hear the talker

*Wireless* headsets are preferable to individual microphones.

This reduces the number of Microphones & Speakers required in 'large' systems.

This also reduces background noise in the system.

Tech Works CI-Buss Products provide additional Feedback Prevention techniques:

Selective Gain Reduction, "Ducking", can be very effective.

When a Microphone is keyed, the associated speaker can have its level automatically reduced.

Usually when the User is speaking, the listener is not talking, and only would need to interrupt.

The speaker level can be much lowered because the user is paying attention to communications.

Jumper Options on the Products allow the "Ducking Level" to be optimally set.

Notch Filtering the Microphone reduces acoustic room resonance peaking.

Rooms without acoustic treatment have significant resonances. This 'peaking' has the effect of greatly increasing gain at these resonance frequencies.

This is significant with directional hanging microphones; floor to ceiling resonances are magnified.

A notch filter can be used to reduce this peaking, without adversely affecting communications.

# CI-HSI-41

The HSI-41 is a stand-alone Headset Intercom, that accommodates four Plantronics Wireless Headsets

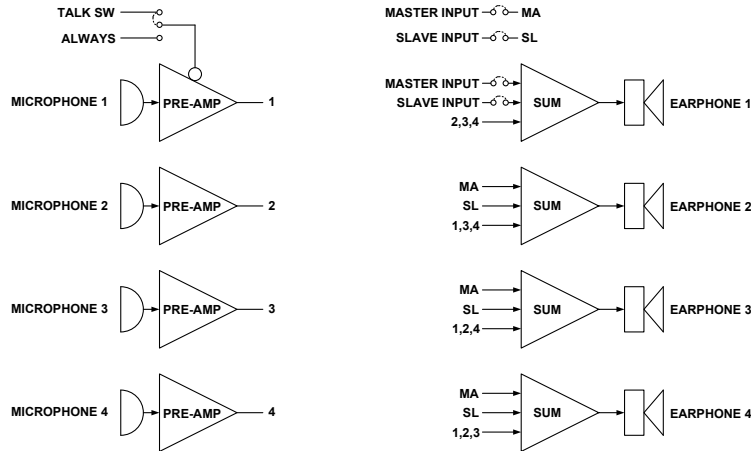

Basic Headset Intercom Block Diagram

Each Headset's microphone is summed to all the other Headsets Earphones except itself. This sum is known as "All others, except me".

The CI-BUSS interface performs the same function for additional units. The Sum of all the Headset microphones is processed with ALC to be of constant level and passed to other Units in both directions. The ALC has an indicator for the Threshold of Limiting. This indicator also serves as a setup indicator for adjusting the Headset microphone levels.

## Front Controls and Indicators:

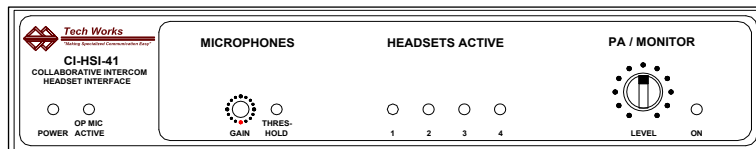

Power indicator: Green when Operating Normally

Operator Mike Active Indicator: Green when the Operator Microphone is Active

Microphone Sensitivity: 16 Position Rotary Switch, factory set to "9"

Setup Level Indicator (THRESHOLD): Off when the BUSSES are not receiving the Headset Microphone outputs; Green, low input level; Green flashing to Red, Normal Operation when ALC is active and the Headset Users are talking

Headset On indicators (4): Green when the Headset is connected, and turned on

Monitor Level Knob Pot: Controls output level to PA-BUSS connector

PA Monitor Indicator: Green when the BUSS has the Audio Output Enabled

**NOTE: The Microphone Gain control is for setup; once done, it should not be touched by the User**

## Rear Connections:

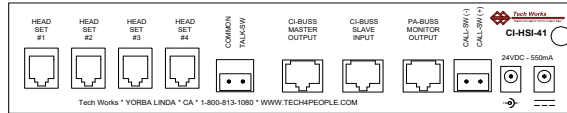

Headsets (Four): Connector: RJ-22, Telephone handset connectors

Talk Switch: Two Position Euro-Style Barrier Strip:

Switch Common

Talk Switch (+) (N.O.)

CI-BUSS, "Master" Connector, RJ-45,

CI-BUSS, "Slave" Connector, RJ-45,

PA-BUSS, "Monitor" Connector, RJ-45,

Call Switch: -Two Position Euro-Style Barrier Strip:

Call Switch (+), (N.O.)

Call Switch (-) *Note: Call Switch must Float W.R.T. Common*

Power Connectors: (Two) - 3.5mm Barrel Connectors

Chassis: Hex nut, Earth Ground

**Note: The Chassis is connected to Circuit Common through a 1-Meg-Ohm resistor**

## Initial Adjustments:

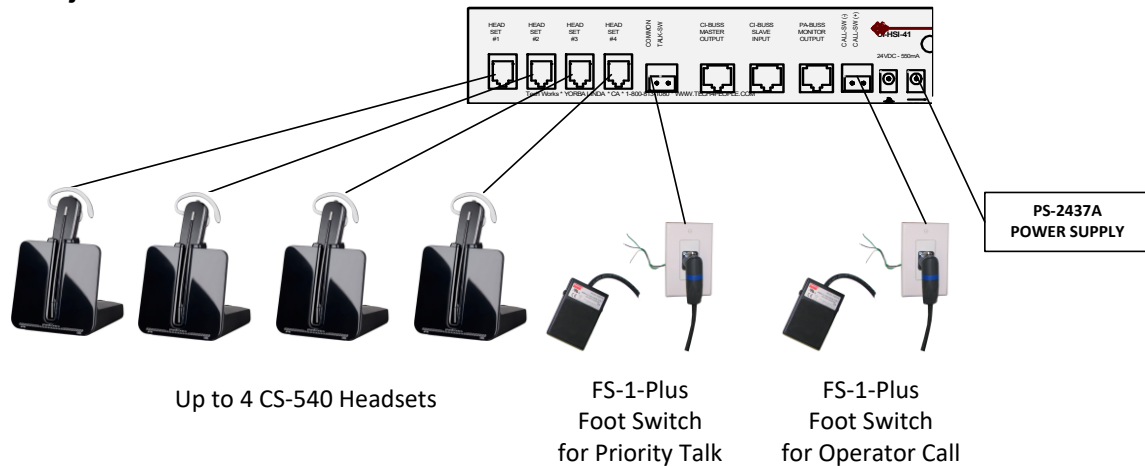

To assure consistent performance **each Headset requires initial adjustments. Please see the headset data sheet for proper set up before connection or operation.**

### HSI-41 Microphone Gain Control: "9"

*Microphone setup should be confirmed, when speaking at a normal level*

*The Setup Indicator on the HSI-41, should flash red*

**After all the microphones are set up, the Listening Levels may be adjusted by the user by adjusting the listening level on the headset itself.**

The "**MONITOR LEVEL**" Control sets the **PA-BUSS output** level.

Fully clock-wise is ~ 0dBm nominal output

There are **several strategies** for using this level setting:

1. Advance the control fully CW, and use the Amplifier Level Control for setting Speaker Levels
2. Set the Amplifier Level Control Fully CW, and use the HSI-41 Level Control to set Speaker Levels
3. If a system has several Amplifiers, the "Level" controls on the amplifiers may be used for 'Balance'; the level control on the HSI-41 may be used as a 'Master Level' control



## The Monitor output, PA-BUSS has many uses

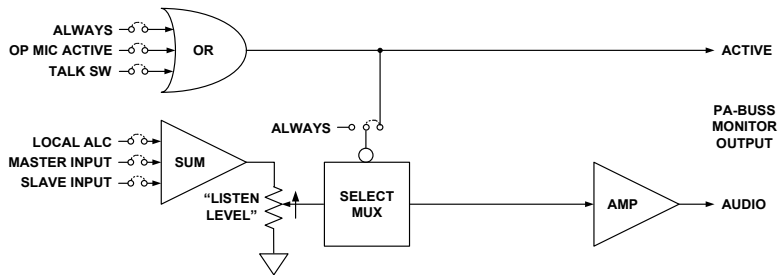

It could be a logging output, for recording the conversation, or just selected individuals  
 It could be a “paging” output  
 It could be used for Patient Communications

There could be Background Music, which is only interrupted when communications or Paging takes place.  
 For the various applications see the ‘PA-BUSS Users Manual’

## The PA-BUSS Monitor has several Audio Selection Choices, which are summed

**Master Connector: ON OFF**  
**Slave Connector: ON OFF**  
**Local ALC Output: ON OFF**

## The Audio May be Keyed (See below) or may always be enabled **KEYED ALWAYS**

## The PA-BUSS Monitor Active Signal (Keying Signal) is selectable, logical OR’ed

Talk Switch Active	<b>TALK_SW</b>	<b>ON OFF</b>
Operator Microphone is Active	<b>OP_MIC_ACTIVE</b>	<b>ON OFF</b>
Always (Overrides other selections)	<b>ALWAYS</b>	<b>ON OFF</b>

## The Collaboration Buss, CI-BUSS allows chaining of several Units

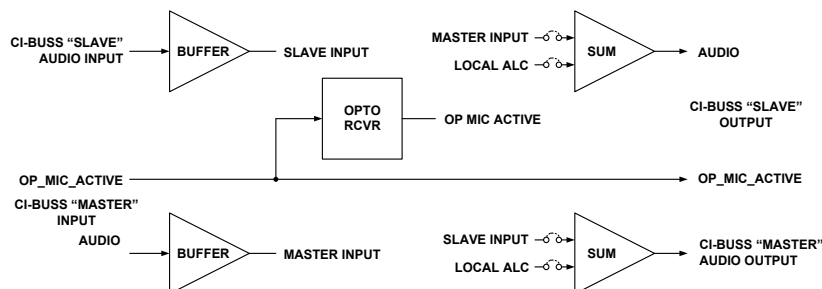

In the Standard Configuration **all the users** of the CI-BUSS **talk and listen to each other**  
 However there may be situations where some users may only listen, or only talk

There are two Collaboration Buss connectors on the HSI-41. One is Labeled “Master” and the other is labeled “Slave”

The Selections allow selective Collaboration

These settings do not affect the Monitor Outputs, PA-BUSS

## Slave IC-BUSS Connector, BUSS Output, Summed:

**Master Connector: ON OFF**  
**Local ALC Output: ON OFF**

## Master IC-BUSS Connector, BUSS Output, Summed:

**Slave Connector: ON OFF**  
**Local ALC Output: ON OFF**

# CI-MSI-22

The MSI-22 is a Microphone and Speaker Interface for our Collaborative Intercom family of products. There can be two Microphones (One from the Microphone Input; one from the PA-BUSS Input using a PA-MI-1)  
Two Speaker outputs (One from the Speaker Output; one from the PA-BUSS output using a AS-1 or PA-402)

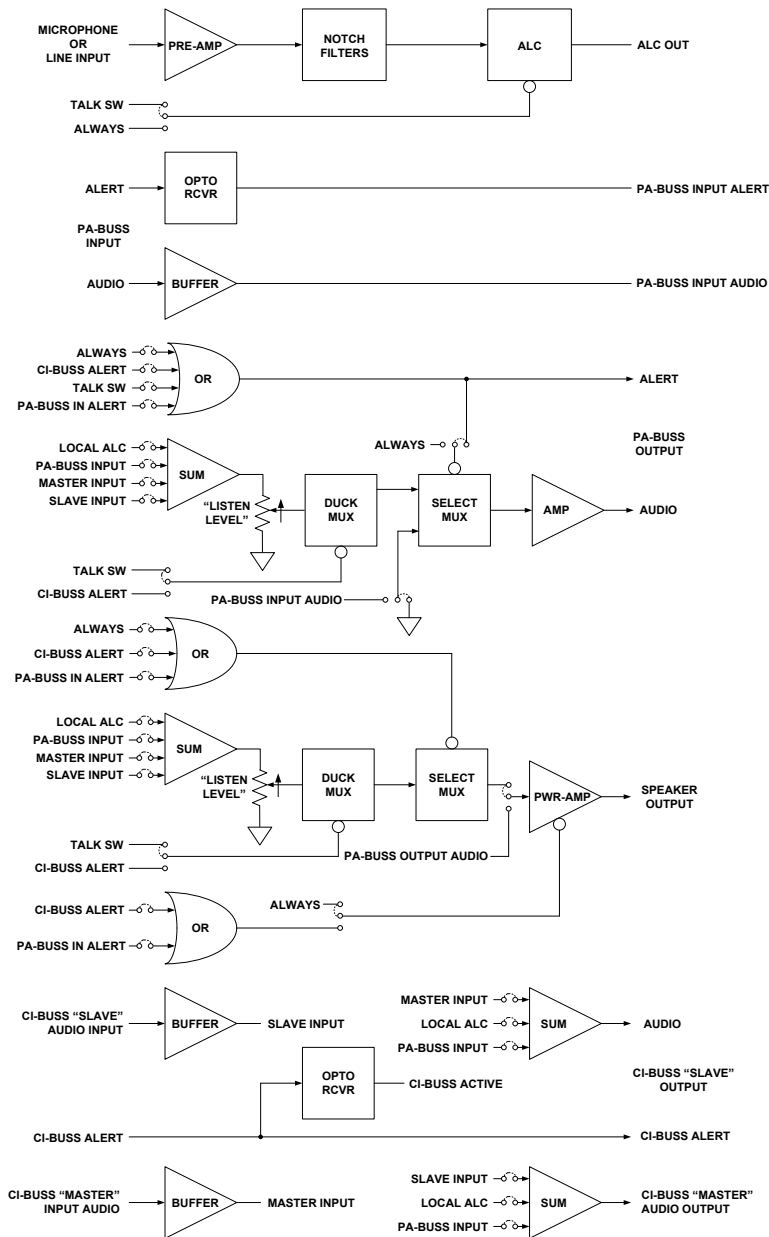

Basic Microphone / Speaker Interface Block Diagram (Transformers not shown for clarity)

Each input can be routed to an output or all outputs by placing routing jumpers inside the unit as desired. The CI-BUSS interface performs the same function for additional units. The Microphone is processed with ALC to be of constant level and passed to other Units in both directions as selected. The ALC has an indicator for the Threshold of Limiting. This indicator also serves as a setup indicator for adjusting the Microphone level.

## Front Controls and Indicators:

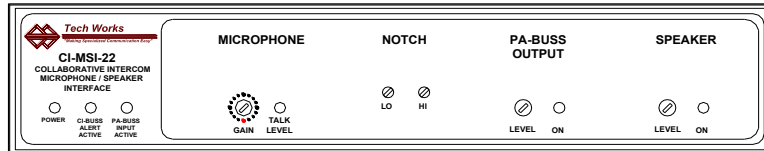

**Power indicator:** Green, when operating Normally

**CI-BUSS, ALERT Active Indicator:** Green, when the *Operator Microphone* is Active

**PA-BUSS Input, ALERT Indicator:** Green, when the PA-BUSS Input is Active

**Microphone Gain:** 16 Position Rotary Switch, factory set to 8, 3dB/Step, 45dB Range

**Talk Level Indicator:** Green, low input level; Green, flashing to Red, Normal Operation, with Local Microphone, and ALC is active

**Notch Filter:** 'LO' Band Notch Filter trimpot, 250 to 1000Hz; 'HI' Band Notch Filter trimpot, 750Hz to 3000Hz

**PA-BUSS Output:** Level Control trimpot; ON Indicator: Green, when the PA-BUS is ON

**Speaker Output:** Level Control trimpot; ON Indicator: Green, when the Speaker Amplifier is ON

**NOTE:** The Microphone Gain control is for setup; once set, it should not be touched by the User

## Rear Connections:

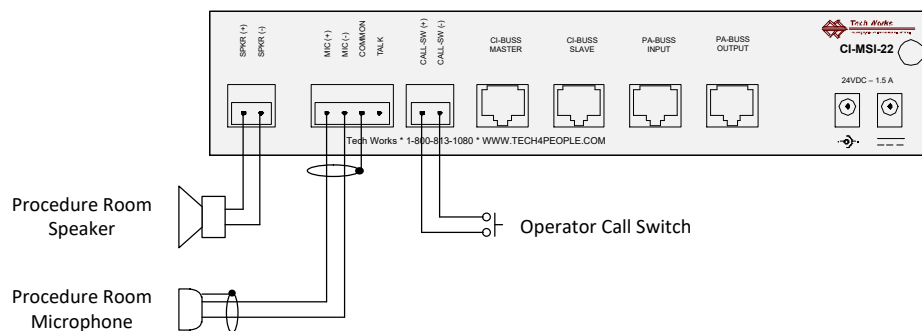

**Speaker Output:** 25-Volts Maximum, 10-Watts Maximum; Two Position Euro-Style Barrier Strip: Speaker (+/-)

**Microphone Input:** Four Position Euro-Style Barrier Strip: Universal Microphone/Line Input (+/-); Shield/Switch Common; Talk Switch (N.O.)

*Selectable Equalization - 3 settings optimized for voice communication*

*Selectable Phantom Power (22 Volts, Short Circuit Protected)*

*Configured for a Microphone Level Input: 2000 Ohms Balanced, -75dBm or -60dBm (Selectable) minimum input (Balanced) for full rated output*

*Configured for a Line Level Input: 2000 Ohms Balanced, 1000 Ohms Unbalanced, Balanced input -35dBm to +5dB or -20dBm to +20dB Accommodation range (Selectable), Un-Balanced Input -30dBm to +10dB or -10dBm to +20dB Accommodation range (Selectable)*

**Call Switch:** Two Position Euro-Style Barrier Strip: Call Switch (+/-), (N.O.)

*Call Switch must Float W.R.T. Common*

**CI-BUSS, "Master" Connector, RJ-45**

**CI-BUSS, "Slave" Connector, RJ-45**

**PA-BUSS, Input Connector, RJ-45, Optionally Powered for a CI-MI-1**

**PA-BUSS, Output Connector, RJ-45, Always Powered for an AS-1, 23 Volts @ 350MA Maximum**

**Power Connectors:** (Two) - 3.5mm Barrel Connectors

Chassis: Knurled nut, Earth Ground

**The Chassis is connected to Circuit Common through a 1-Meg-Ohm resistor**

## Initial Adjustments:

There are both **Input and Output Controls with associated Indicators**

When the Indicators are green the associated control is enabled

The Audio may be 'Keyed' depending on the Configuration and system setup

**Only attempt adjustments if the associated indicator is lighted green!**

The CI-BUSS uses a standard audio level of ~0dBm RMS

The Digital Rotary Switch (3dB/Step) is used to set Microphone Gain

The nominal Microphone gain is ~6dB, or less, into limiting

Microphone Gain is always setup first

Initially, the Output level controls should be set to minimum (No Output)

## Limiters Setup with a Microphone:

*Always do first*

Provide a normal input to the Microphone, or Line input

Insure the Microphone is Keyed, the indicator is Green

Advance the "Microphone Gain", from "0" until the Talk Level indicator just flashes red

Advance the "Microphone Gain" no more than two clicks (6dB into limiting)

## Monitor/Communications and Speaker setup:

*Assure there is an audio input*

With normal audio input levels, with Inputs and outputs keyed (Output Indicator Green)

Set the Speaker Listening Level

See the PA-BUSS Section for Monitor/Communications Output Adjustments

## Notch Filter Setup: *Do after initial setup*

The factory settings are: LO, fully CCW, HI, Fully CW; the Notch Filters are essentially disabled

Notch Filters can greatly reduce feedback; however they cannot make up for poor acoustic isolation

There are two distinct primary resonance modes in most installations. One is room resonance; one mode is most prevalent, such as floor to ceiling resonance. This frequency is usually on the order of a few hundred cycles. The second mode is the distance of the microphone from a near object. This frequency is much higher near 1000Hz. The MSI-22 incorporates two filters in tandem, one a low Band Filter 250Hz to 1000Hz, and the other a High band Filter 750Hz to 3000Hz

Adjust the Notch Filters one at a time. Increase the Microphone Gain Control until feedback occurs. Make a rough determination of the frequency (or measure the frequency with a counter).

If the feedback is below ~800Hz, adjust the 'Lo Notch' until feedback ceases. If the feedback is above ~800Hz, adjust the 'Hi Notch' until feedback ceases. (This is a 20-turn pot so it is best to start from one extreme, and slowly turn the pot in the other direction)

Increase the Microphone Gain Control until feedback occurs again, if it is at the same frequency; try finely adjusting the same filter to see if the feedback can be eliminated. If the frequency is different, and in the other range not already tuned, repeat the steps above

If only one Notch Filter is required, the other filter should be set at the extreme of its range. Fully CCW (lowest frequency) for the LO filter, and fully CW (highest frequency) for the HI filter.

*After the Notch Filters are adjusted, redo the initial adjustment above*

## Note:

**Before making any adjustments assure there are audio Inputs and Outputs**

All the associated indicators must be lighted green

## Configuration Options:

The MSI-22 is designed to accommodate many applications. **For most applications the factory default setting is sufficient.** For 'special' applications a few jumpers may need to be moved. These Jumpers determine how the MSI-22 interacts with other Components of the System

**Before attempting a Configuration you should review the "BUSS Systems Guide" CI & PA, BUSS sections**

The **MSI-22 consists of five Functional Modules:**

**Two Inputs;** Local Microphone/Line Input; PA-BUSS Input

**Two Outputs;** PA-BUSS Monitor/Communications Output; Speaker Amplifier

### CI-BUSS Interface

The **Jumper Options determine how these Modules interact and function with each other**

**The "Standard Configuration" is a Remote (Single Location) for use with an Operator Console**

This is a Remote (Single Location) for use with an Operator Console, CI-ODC

The Power Amplifier, is used for a Procedure Room *Ceiling* Speaker

The PA-OUT, is used as Procedure Room Communications

The PA-IN, may or may not be used for another Microphone

The CI-BUSS may be used with other Interfaces, such as a CI-HSI-41

## Jumper Options

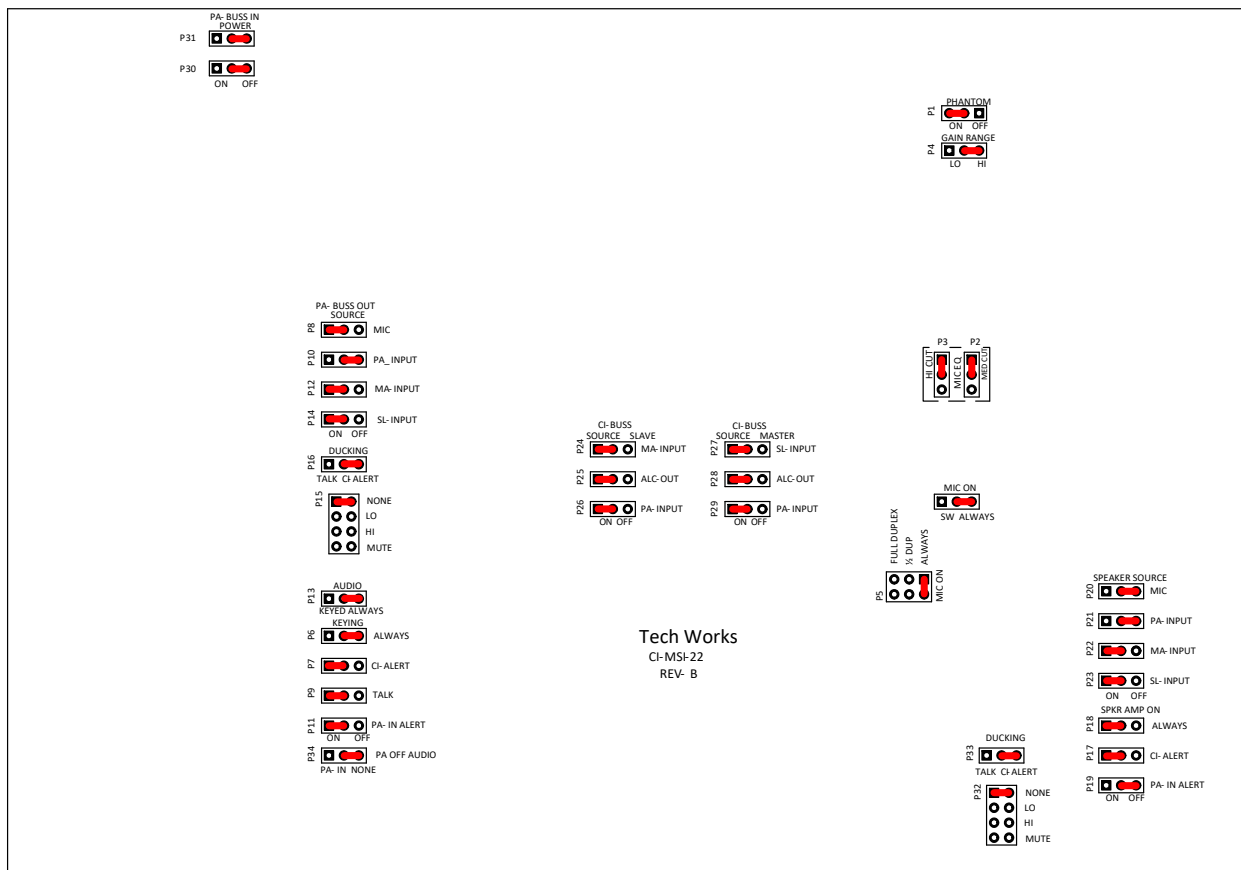

# CI-ODC-1-B

The Tech Works CI-ODC-1-B Operator Desk Console is part of the Collaborative Intercom product group. The Console includes a professional cardioid, condenser, gooseneck microphone, and a speaker. Buttons and indicators provide control to allow the operator to just listen to the CI-Buss communication or to talk, and collaborate hands free. A headset jack on the side of the console allows connection of a local operator headset such as the CS-540 wireless unit.

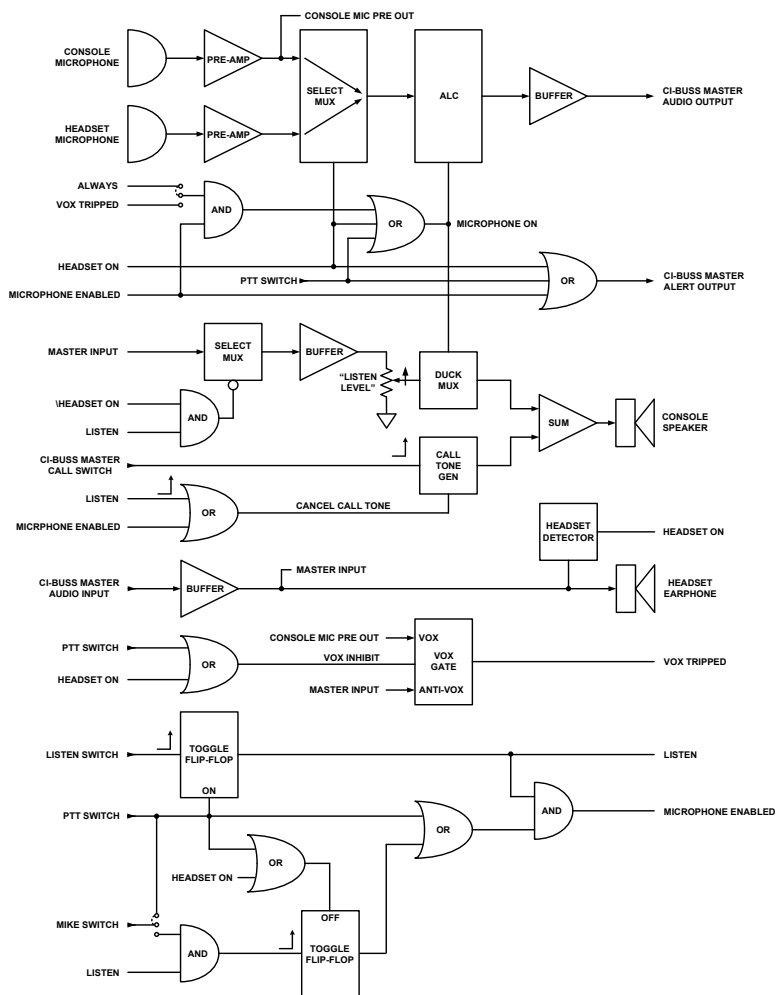

Basic Operator Console Block Diagram

Isolation Transformers not shown for simplicity

The CI-BUSS interface allows connection of additional units. The Microphones are processed with ALC to be of constant level and passed to other Units

The ALC has an indicator for displaying the Microphone level.

## Controls and Indicators:



### Front, Vertical Face:

**Power Indicator**, Green when Operating Normally

**Microphone Input Level Indicator/VOX Indicator:**

Off (VOX not tripped), microphone off ; Red, Low audio Level ; Flashing Green; Normal audio level

**Headset On Indicator:** Green when the Operator Wireless Headset is ON;

When the Headset is ON, the Console Microphone, Speaker, and Switches, are disabled

### Sloped Face:

**LISTEN Switch** (Toggle Action)

**Remote Station Selected Indicator:**

Red when selected - *Controls both the Listening and Talking to the Remote Station*

**Console TALK Switch** (Toggle Action with VOX, or Momentary when Push-to-Talk)

**TALK Indicator:**

Red when Microphone is enabled - *Allows listening without interrupting the Remote Conversation*

### Side:

**Console Speaker Listening Level** (Knob Pot, Side)

*The Console Speaker Level Adjustment is limited, the speaker may not be turned completely off*

### Rear Connections:



**CI-BUSS, "Master" Connector**, RJ-45,

**PA-BUSS, "Output" Connector**, RJ-45

**Footswitch** (Optional), 1/4" TRS Jack - *Used for 'Push-to-Talk' Operation*

**Power Connector:** 3.5mm Barrel Connectors - **24Volts, 1 Amps Maximum**

Chassis, Earth Ground: Hex Nut, the Chassis is connected to Circuit Common through a 1-Meg-Ohm resistor

### Side Connections:

**Headset Connector**, RJ-22, Plantronics, Wireless Headset (Optional)

### The Headset requires initial adjustments (See Headset Datasheet)

Configuration Switch: "A"

Earphone Switch: "4"

Microphone Switch: "6"

The Console Speaker listening level may be adjusted to be heard throughout the room  
When the Console Microphone is enabled the Console Speaker listening level is reduced to a lower level to prevent feedback

There is a **Remote Call Switch in the Procedure Room to get the attention of the Operator**,  
The Call Tone comes through the Console Speaker, only if the Console Microphone is not enabled  
*If the Procedure Room is in a Conversation with the Operator, it is assumed the Call Switch will not be used*

### **There are two Operational Configurations**

#### **VOX (Voice Activated), or Push-to-Talk, Microphone**

***The user should read the section below that pertains to their configuration***

#### **VOX (Voice Activated Microphone) Operation (Standard Option):**

Basic Console Operation is straightforward and intuitive

When the Operator wants to converse with the Procedure Room

The "**LISTEN**" switch is pushed, the indicator lights Red

If the Operator wants to end the conversation, the "**LISTEN**" switch is pushed again, the indicator goes off

The Operator may disable the microphone with the "**TALK**" Switch", to only listen to the Procedure Room

When the "**TALK**" switch is pushed, the indicator goes off to indicate the Console Microphone is disabled

When the "**TALK**" switch is pushed again, the indicator lights red, to indicate the Microphone is enabled

#### **When the microphone is enabled, the Switchover is Voice Activated (VOX)**

The Operator must speak directly into the Console Microphone

*At a distance of ~6" for proper response*

The "LIMIT/VOX" indicator lights Green to indicate the VOX is tripped

**During normal operation, the "LEVEL/VOX" Indicator flashes Red** to indicate proper microphone level

*If the Operator wants to continue listening without talking the Microphone should be disabled (Push the "**TALK**" Switch again)*

*TALK may only be changed while listening*

*When listening is discontinued the state of TALK is retained*

*This allows the Listen Switch to Control both Listening and Talking*

#### **Push-to-Talk Microphone Operation, (Jumper Option):**

Basic Console Operation is straightforward and intuitive

When the Operator wants to converse with the Procedure Room

The "**LISTEN**" switch is pushed, the indicator lights Red

If the Operator wants to end the conversation, the "**LISTEN**" switch is pushed again, the indicator goes off

When the **TALK** Switch is pressed: The Console Microphone is activated

And the Console Speaker is forced to **Listening**, when the Switch is Released the Console remains

**Listening**

*If the Operator wants to discontinue listening the "**LISTEN**" switch should be pressed*

#### **When the microphone is enabled**

The Operator must speak directly into the Console Microphone

*At a distance of ~6" for proper response*

The "LIMIT/VOX" indicator lights Green to indicate the Microphone is on

**During normal operation, the "LEVEL/VOX" Indicator flashes Red** to indicate proper microphone level

#### **Operation with Accessories:**

***The PTT Foot Switch allows hands free operation, and overrides VOX if the Environment becomes noisy***

**If the Operator has a Push-to-Talk Foot Switch (Optional)**

**PTT disables VOX mode**

**When the Foot Switch is pressed the Console Microphone is immediately activated**

**When the Foot Switch is Released the Console returns to Listening**

**The Wireless Headset allows the Operator to move about the room, while carrying on a conversation with the Procedure Room**

**If the Operator has a Wireless Headset (Optional), The Wireless Headset has an ON/OFF switch, when the Headset is 'Off' the function is the same as above. The Headset has priority, and converses with the Procedure Room when the "HEADSET ON" indicator is lighted; The Console Microphone, Speaker, and Switches, are disabled, The Listen and Talk indicators are forced off**

**Configuration Jumpers (Console Cover Removed):**

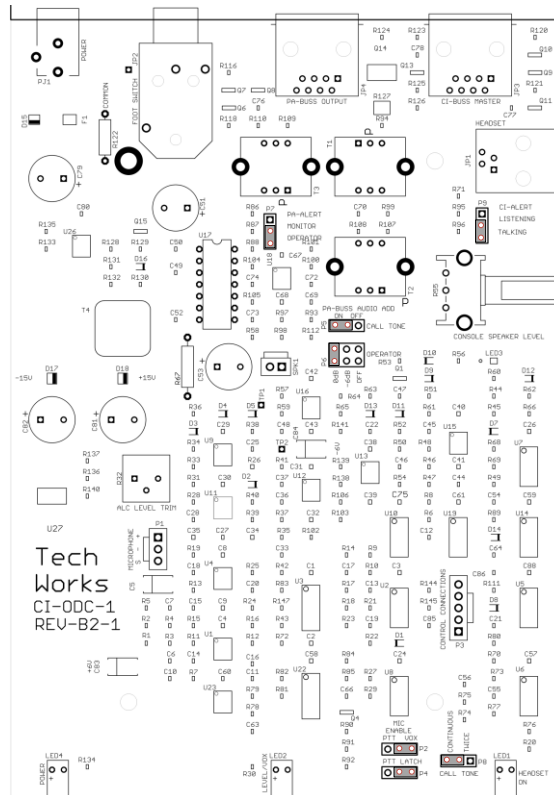

**Jumper:**

Option				Function
<b>P7 PA-ALERT</b>	<b>MONITOR</b>	<b>OPERATOR</b>		<b>PA-Buss Alert signal sent All the Time or Only When Operator is Enabled?</b>
<b>PA-BUSS Audio P5 Call Tone</b>	<b>ON</b>	<b>OFF</b>		<b>Is the Call Tone sent to the PA-Buss?</b>
<b>PA-BUSS Audio P6 Operator</b>	<b>0dB</b>	<b>-6dB</b>	<b>OFF</b>	<b>How Loud should the Operator be from the PA-Buss? Full, Down Slightly, or Not at All (OFF)</b>
<b>P9 CI-Alert</b>	<b>LISTENING</b>	<b>TALKING</b>		<b>When is the CI-Alert Signal sent?</b>
<b>P2 Mic. Enable</b>	<b>VOX</b>	<b>PTT</b>		<b>Console Mic On Automatic (VOX) or only when the button is Held?</b>
<b>P4 Talk Button</b>	<b>LATCH</b>	<b>PTT</b>		<b>Talk Button Push On/Push Off or Push and Hold</b>

**Cleaning** – If the product becomes dirty and requires cleaning DO NOT USE CLEANING CHEMICALS SUCH AS 409, SIMPLE GREEN, or other solvents. If possible, only use water to make a damp soft cloth and rub lightly to preserve the finish. If further cleaning or disinfecting is required, use only isopropyl alcohol on a soft cloth. Alcohol may dull the finish of the product but will not harm the electronics.

# CI-ODC-4

The Tech Works CI-ODC-4 Operator Desk Console is part of the Collaborative Intercom product group. The Console includes a professional cardioid, condenser, gooseneck microphone, and a speaker. Buttons and indicators provide control to allow the operator to just listen to the CI-Buss communication or to talk, and collaborate hands free. A headset jack on the side of the console allows connection of a local operator headset such as the CS-540 wireless unit.

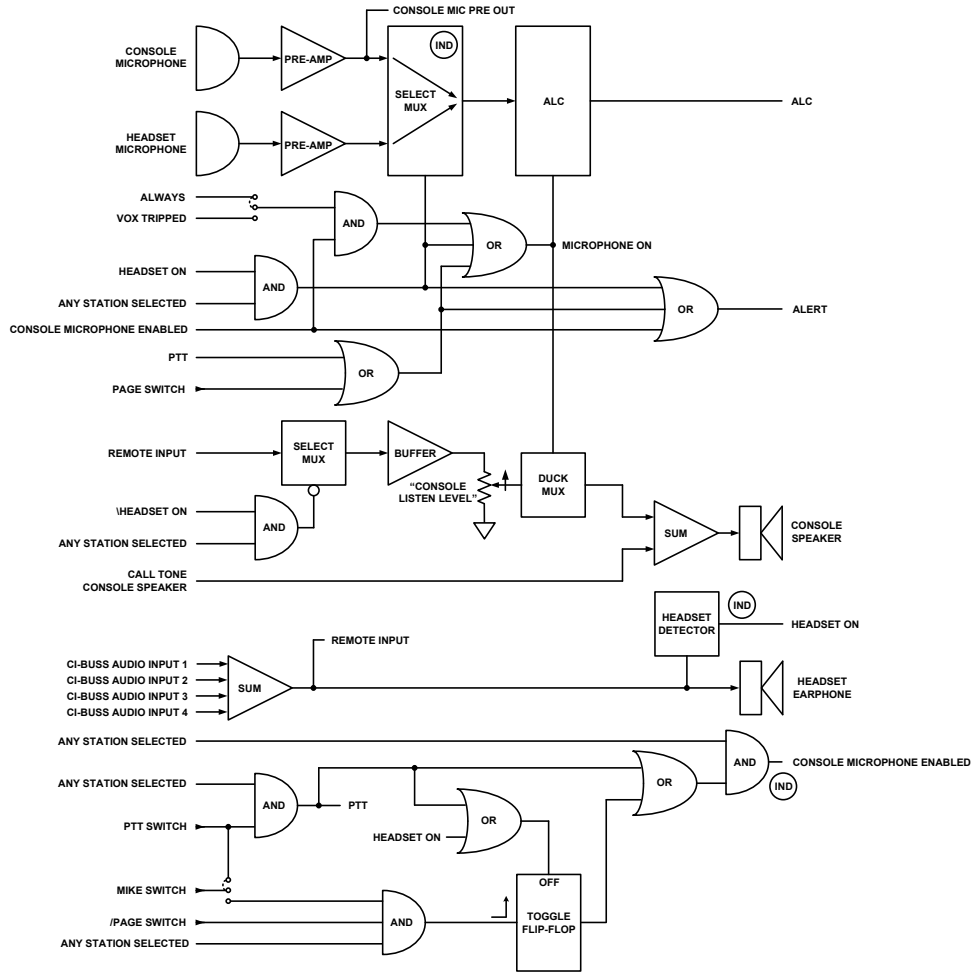

Basic Operator Console Block Diagram

Isolation Transformers not shown for simplicity.

The CI-BUSS interface allows connection of additional units.

The Microphones are processed with ALC to be of constant level and passed to other Units.

The ALC has an indicator for displaying the Microphone level.

## Controls and Indicators:



### Sloped Face:

**Station Select Switches**, 4 Toggle Action

**Remote Station Indicators**, Four

Red when selected

Flashing when a Call is pending

Off when not active

*Controls both the Listening and Talking to the Remote Station*

**Console TALK Switch** (Toggle Action, or Momentary)

**TALK Indicator**,

Red when Microphone is enabled

*Allows listening without interrupting the Remote Conversation*

*Has no affect on the Headset*

### Front, Vertical Face:

**Power Indicator**, Green when Operating Normally

**Microphone Input Level Indicator/VOX Indicator:**

Off (VOX not tripped), microphone off

Red, Low audio Level

Flashing Green; Normal audio level

**Headset On Indicator:** Green when the Operator Wireless Headset is ON; *When the Headset is ON, the Console Microphone, Speaker, and Switches, are disabled*

### Side:

**Console Speaker Listening Level** (Knob Pot, Side)

*The Console Speaker Level Adjustment is limited, the speaker may not be turned completely off*

### Rear Connections:

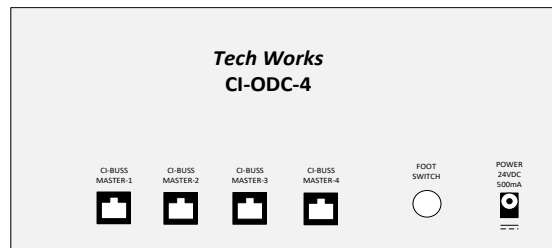

**CI-BUSS, "Master" Connectors**, RJ-45, (Four)

**Footswitch** (Optional), 1/4" TRS Jack - *Used for 'Push-to-Talk' Operation*

**Power Connector:** 3.5mm Barrel Connectors - **24Volts, 1 Amps Maximum**

Chassis, Earth Ground: Hex Nut, the Chassis is connected to Circuit Common through a 1-Meg-Ohm resistor

### Side Connections:

**Headset Connector**, RJ-22, CS-540, Plantronics, Wireless Headset (Optional)

**The CS-540 requires initial adjustments**

Configuration Switch: "A"

Earphone Switch: "4"

Microphone Switch: "6"

## Operation:

The Console Speaker listening level may be adjusted to be heard throughout the room  
When the Console Microphone is enabled the Console Speaker listening level is reduced to a lower level to prevent feedback

If there is a **Remote Call Switch in the Procedure Room to get the attention of the Operator**,  
The Call Tone comes through the Console Speaker, only if the Console Microphone is not enabled  
*If the Procedure Room is in a Conversation with the Operator, it is assumed the Call Switch will not be used*

**There are two Operational Configurations**  
**VOX (Voice Activated), or Push-to-Talk, Microphone**  
***The user should read the section below that pertains to their configuration***  
**VOX (Voice Activated Microphone) Operation (Standard Option):**

Basic Console Operation is straightforward and intuitive  
When the Operator wants to converse with the Procedure Room

### Station Selection & Indication:

Pushing a Station Button Selects that Station (Toggle Action)  
Pushing the (Active) Station Switch again, deselects that station  
Pushing another Station Switch selects that station and deselects the previous station

When a Station is not selected its indicator is Off  
When a Station is Selected, its Indicator is On  
A flashing Station Indicator, indicates that station is Calling  
Selecting a Calling Station cancels that stations Call

The Operator may disable the microphone with the "**TALK**" Switch", to only listen to the Procedure Room  
When the "**TALK**" switch is pushed, the indicator goes off to indicate the Console Microphone is disabled  
When the "**TALK**" switch is pushed again, the indicator lights red, to indicate the Microphone is enabled

### **When the microphone is enabled, the Switchover is Voice Activated (VOX)**

The Operator must speak directly into the Console Microphone  
*At a distance of ~6" for proper response*  
The "LIMIT/VOX" indicator lights Green to indicate the VOX is tripped  
**During normal operation, the "LEVEL/VOX" Indicator flashes Red** to indicate proper microphone level

*If the Operator wants to continue listening without talking  
the Microphone should be disabled (Push the "**TALK**" Switch again)*

*TALK may only be changed while listening  
When listening is discontinued the state of TALK is retained  
This allows the Listen Switch to Control both Listening and Talking*

### **Push-to-Talk Microphone Operation, (Jumper Option):**

When the **TALK** Switch is pressed: The Console Microphone is activated  
And the Console Speaker is ducked for maximum gain before feedback, when the Switch is Released the Console returns to full **Listening**

### **Call Tone:**

Call Tone Runs anytime a Call is Pending and no Station is Selected  
The Call Tone is a 'Warble Sequence', repeating every 15 Seconds, until a Station is selected  
*The Console Speaker carries the Call Tone at a Fixed Level*

**Operation with Accessories:**

The PTT Foot Switch allows hands free operation, and overrides VOX if the Environment becomes noisy

If the Operator has a Push-to-Talk Foot Switch (Optional)

PTT disables VOX mode

When the Foot Switch is pressed the Console Microphone is immediately activated

When the Foot Switch is Released the Console returns to Listening

The Wireless Headset allows the Operator to move about the room, while carrying on a conversation with the Procedure Room

If the Operator has a Wireless Headset (Optional)

The Wireless Headset has a an ON/OFF switch, when the Headset is ‘Off’ the function is the same as above

The Headset has priority, and converses with the Procedure Room when the “HEADSET ON” indicator is lighted Red;

The Console Microphone, Speaker, and Switches, are disabled

The Listen and Talk indicators are forced off

**Configuration:**

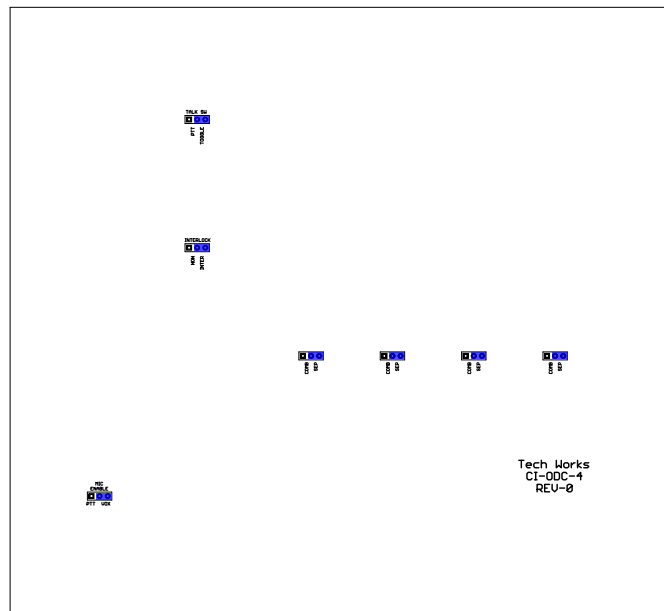

**Jumper:**

	<b>As Shipped Jumpers to the Right</b>	<b>Move both Jumpers to the Left</b>
<b>Operation</b>	<b>HANDS FREE OPERATION</b>	<b>PTT OPERATION</b>
<b>P2 Mic. Enable</b>	<b>VOX</b>	<b>PTT</b>
<b>P3 Talk Sw</b>	<b>TOGGLE</b>	<b>PTT</b>

Other Combinations are allowed and give special functionality where required like VOX with PTT or PTT with TOGGing Button.

Cleaning – If the product becomes dirty and requires cleaning DO NOT USE CLEANING CHEMICALS SUCH AS 409, SIMPLE GREEN, or other solvents. If possible only use water to make a damp soft cloth and rub lightly to preserve the finish. If further cleaning or disinfecting is required, use only isopropyl alcohol on a soft cloth. Alcohol may dull the finish of the product but will not harm the electronics.

Some examples of system wiring are a Cath Lab or Procedure Room with a Shotgun Microphone and background music.

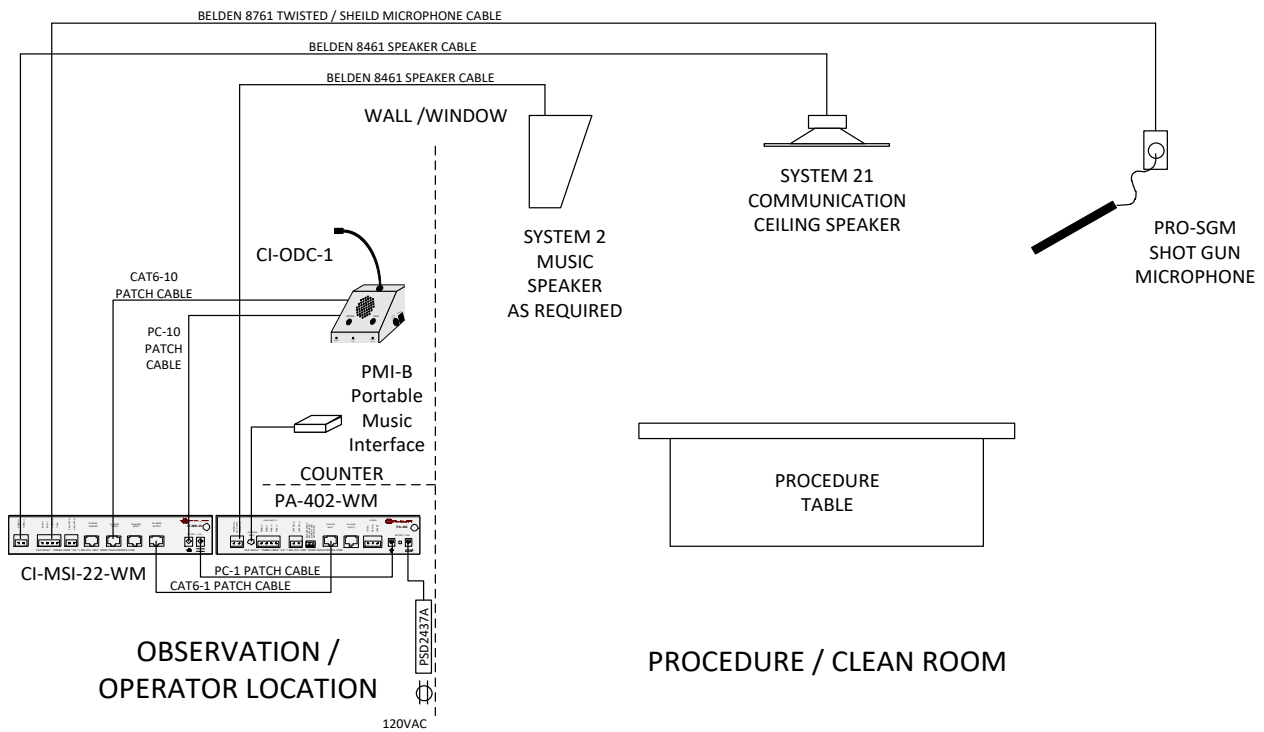

A Cath Lab or Procedure Room with Headsets and a Background Music System with all of the electronics mounted under the counter in the Observation Room

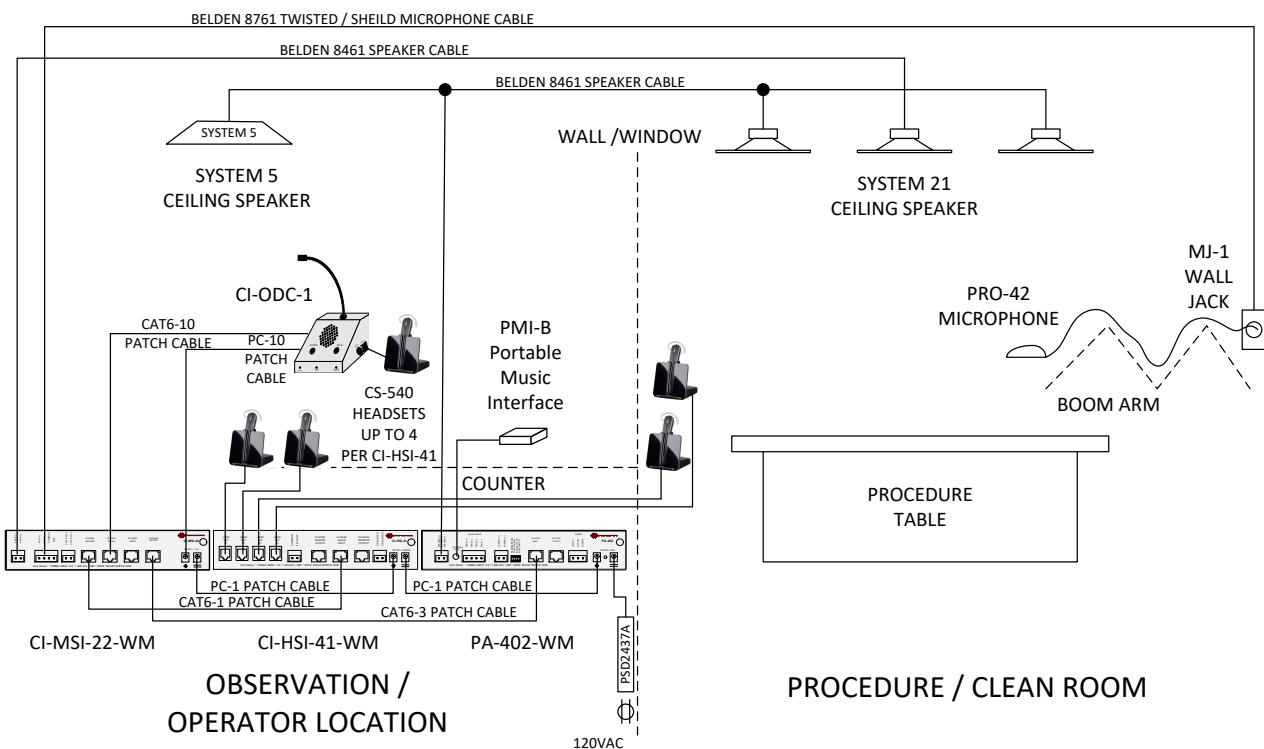

A Procedure Room with a Hanging Microphone and a Powered Speaker Interface to allow more people to hear what is going on in the Observation area.

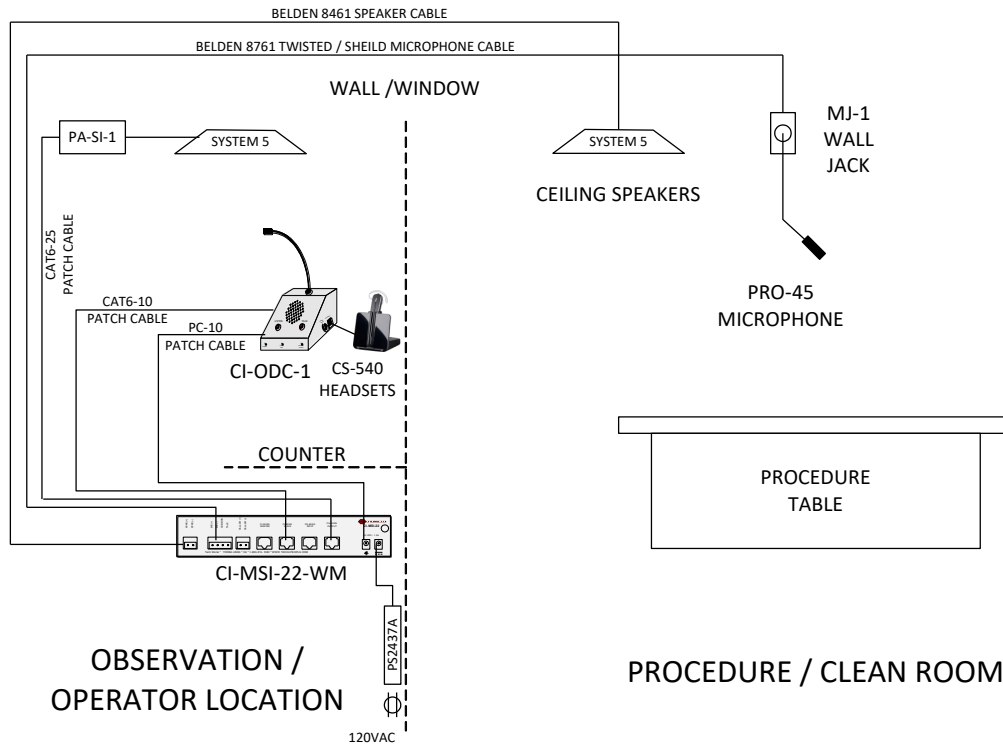

Sleep / Observation Room with Hidden Microphone

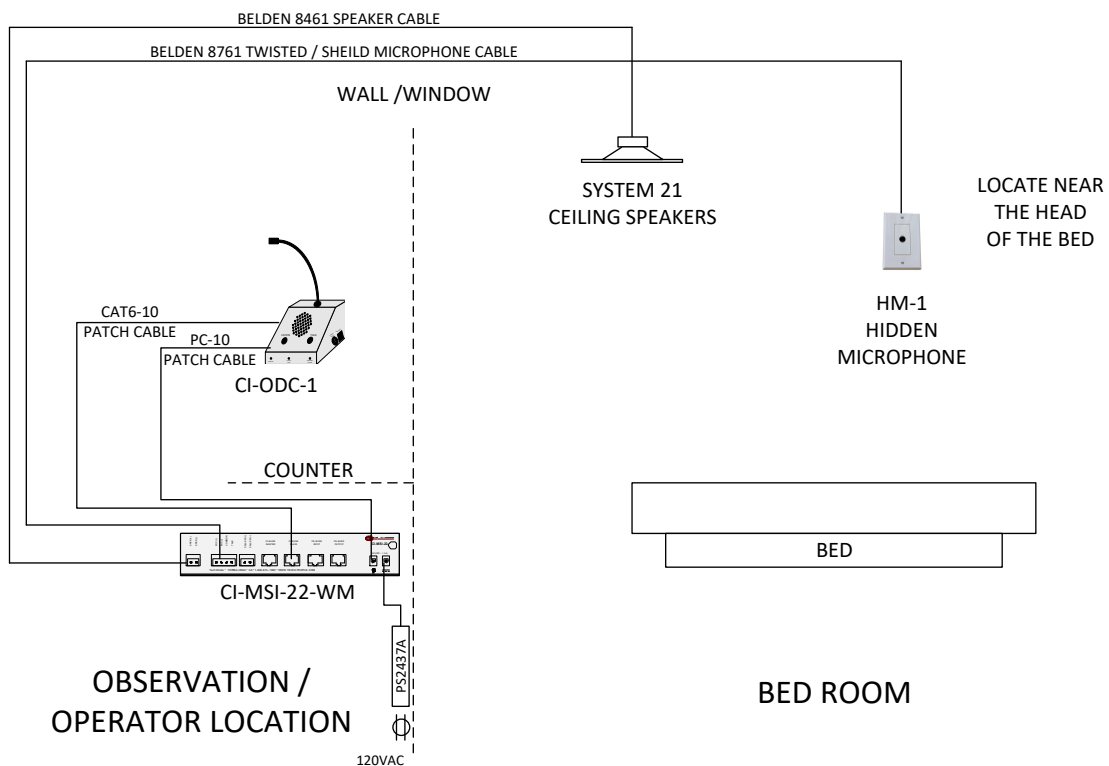

## Pharmacy, Sterile Compounding Clean Room Intercom for 4 Clean Rooms

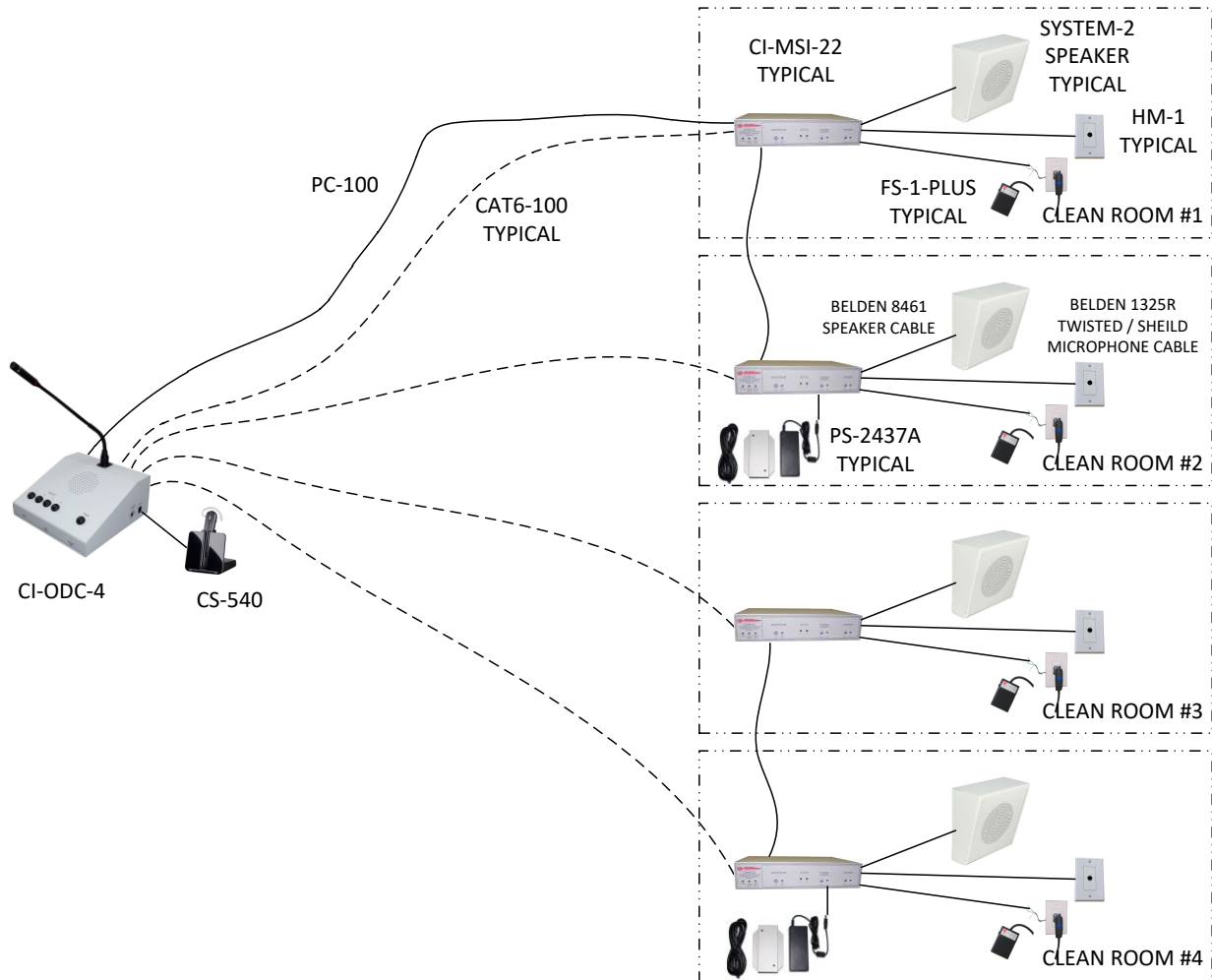

## Simple Bank Teller Window Intercom

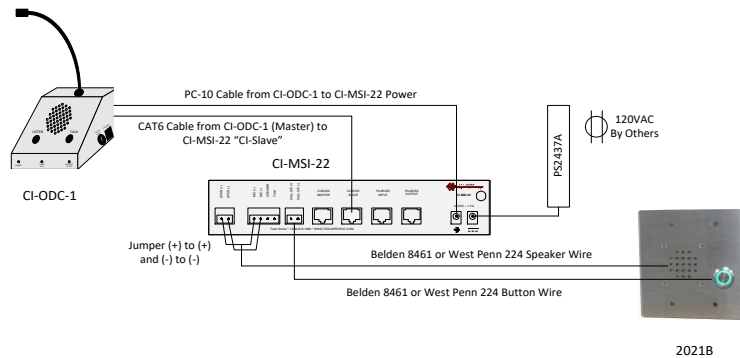

## Packaging & Mechanical:

1U, Half Rack, 8.60" X 1.75" X 6.00"

Mounting Options: Table-Top; Under Counter; Rack

Modular aluminum and steel enclosure

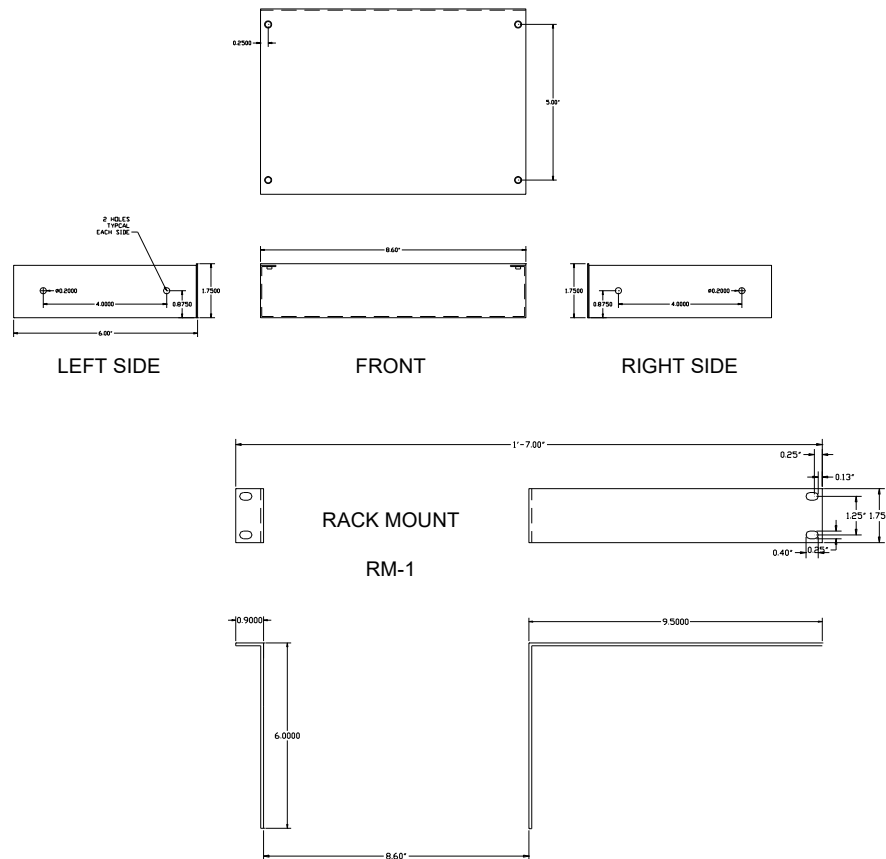

**WM - WALL OR UNDER COUNTER MOUNT** – All Tech Works Universal Box products are available with 1" metal tabs on each side of the unit for easy attachment to either a wall or the underside of a counter using the WM-1. Also available in a side by side WM-2.

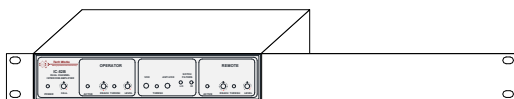

**RM RACK MOUNT** - All Tech Works Universal Box products can be rack mounted as either a single unit RM-1, dual units (side by side) RM-2, or as companions with accessories like the PA-402 Amplifier. The rack mount is 1 rack unit (1-7/8") High by EIA 19" Wide.

## Installation Best Practices and Frequently Asked Questions:

Always connect the Collaborative Intercom active components from Master to Slave on the CI-BUSS.

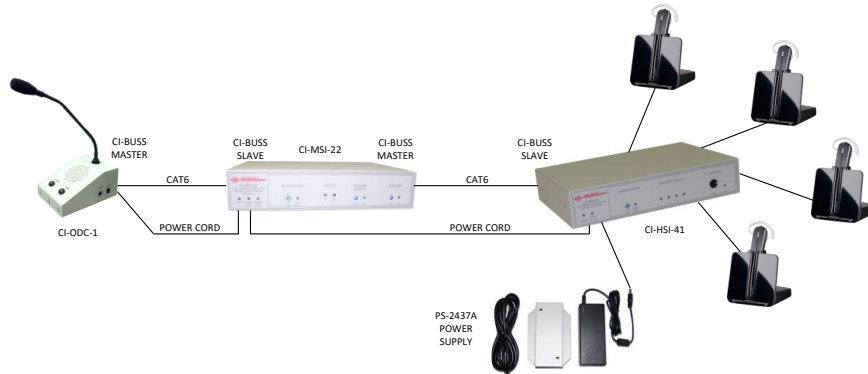

By placing the CI-MSI-22 in the middle of the system it can act as an audio router for who hears who.

By placing the Power Supply on the last device in the chain you can back feed the entire system using standard Power Cords. To add more headsets just add another CI-HSI-41 to the one shown and move the power supply to the new unit. Expansion of up to, no more than, 6 units, on the CI-Buss will give the best performance.

If you absolutely have to have 2 Operator Desk Console on one CI-MSI-22 you can use a crossover cable and connect the second ODC to the “CI-Master” Connector

NORMAL CI-BUSS: RJ-45 Cable wired 1 to 1; Ethernet Standard Wiring			CI-BUSS: RJ-45 Cable wired CROSS-OVER Wiring		
“MASTER” CONNECTOR	TIA 568B COLOR	“SLAVE” CONNECTOR	“MASTER” CONNECTOR	TIA 568B COLOR	“MASTER” CONNECTOR
CALL_SW_(+) (1)	← WHITE OF ORANGE →	(1) CALL_SW_(+)	CALL_SW_(+) (1)	← WHITE OF ORANGE →	CALL_SW_(+) (1)
CALL_SW_(-) (2)	← ORANGE →	(2) CALL_SW_(-)	CALL_SW_(-) (2)	← ORANGE →	CALL_SW_(-) (2)
MASTER_IN_(+) (3)	← WHITE OF GREEN →	(3) SLAVE_OUT_(+)	MASTER_IN_(+) (3)	← WHITE OF GREEN →	MASTER_IN_(+) (3)
MASTER_OUT_(+) (4)	← BLUE →	(4) SLAVE_IN_(+)	MASTER_OUT_(+) (4)	← BLUE →	MASTER_OUT_(+) (4)
MASTER_OUT_(-) (5)	← WHITE OF BLUE →	(5) SLAVE_IN_(-)	MASTER_OUT_(-) (5)	← WHITE OF BLUE →	MASTER_OUT_(-) (5)
MASTER_IN_(-) (6)	← GREEN →	(6) SLAVE_OUT_(-)	MASTER_IN_(-) (6)	← GREEN →	MASTER_IN_(-) (6)
ALERT_IN_(+) (7)	← WHITE OF BROWN →	(7) ALERT_OUT_(+)	ALERT_IN_(+) (7)	← WHITE OF BROWN →	ALERT_IN_(+) (7)
ALERT_IN_(-) (8)	← BROWN →	(8) ALERT_OUT_(-)	ALERT_IN_(-) (8)	← BROWN →	ALERT_IN_(-) (8)

Signal Pairing: (1,2) Control; (3,6) Audio; (4,5) Audio; (7,8) Control

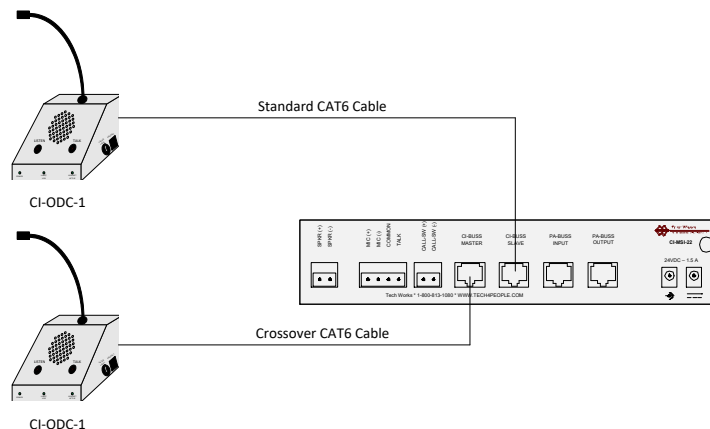

**Notes:**

# ***Tech Works***

CI-Series Collaborative Intercom System

Planning and Installation Manual

Back Page