



# ICA-202D

## TWO CHANNEL AUDIO INTERCOM AMPLIFIER OPERATION AND INSTALLATION MANUAL



The ICA-202D is the most versatile Audio Intercom available; yet it is also the easiest to integrate into your design. With 20 watts of clean audio power at 25-Volts it can do both the Intercom and the Paging functions in most facilities. The audio quality of the ICA-202D is superb. Noise and distortion are very low. Selectable equalization optimizes voice communications.

There are separate controls for Audio Level, and Reach. Once set, Automatic Level Control (ALC) assures the speaker level remains constant over a wide dynamic input range. The Remote user may wander throughout the room and still be heard at a nearly constant level without any operator adjustments.

A Privacy Tone, to alert the remote party that someone is listening, is a control option. If selected the privacy tone will sound every 20 seconds unless the PTT is pressed.

The logic interface is PLC compatible. Control options include Remote Operator Listen Level control from push buttons or Touch Screen, Privacy Tone, Page, PTT, Mute, Activate, Shut Off, and Call Tone, which is automatically routed to the operator speaker. A Line level output for recording is included. A separate Page line level output provides audio to paging amplifiers if required. A Page Pre-Announce Tone (jumper option) is available.

All configuration settings are factory presets; only the speaker levels are set in the field. The microphone sensitivity (Reach) is set with 16 position (3dB/Step) switches; the Speaker Levels are adjusted with Back Panel Controls.

### BENEFITS

- Fully Configurable
- Easily Repeatable Settings
- Digital Microphone Sensitivity
- High Quality Audio
- Automatic Level Control
- External Reach Digital Stepper
- Solid State Switch <3mS
- Integral Privacy
- Selectable Call Tones
- Line Level Recording Output
- Page Output
- 20 Watts Audio Power

### Design Information:

Dual Channel Universal Audio Intercom Amplifier

Inputs: R.F. and static electricity protected

Outputs: short circuit protected

Frequency Response: 250 Hz to 10KHz

Remote Speaker Output:

Balanced 20-Watts RMS, Into 25 Volt transformer loads

Operator Speaker Output: 3 Watts into 25 Volt speaker

Distortion at Full Rated Output < 1% T.H.D

Microphone Inputs:

1000 Ohms Balanced

-80dBm minimum input for full rated output

Selectable Equalization optimized for voice communication

Phantom Power: 23 Volts

Color: Light Gray metal enclosure

Power: 24VDC, 2A Power Supply (sold separately)

**Unit is intended to be used with class 2 power source**

Weight: 3 lbs.

Dimensions: 8.5" W X 1.75" H X 6" D

Mounting: Desk Mount (DM), Rack Mount (RM), Dual Rack Mount (RM2), and Wall Mount (WM)

Connections: Euro-Style Pluggable Screw Terminals



# Tech Works®

"Making Specialized Communication Easy"

---

---

## How to use this Manual

Those wishing to use one of the standard **Configuration Templates**, should first read the *Overview*, and then proceed to the appropriate **Configuration Template** for your application. The *Setup* and *Adjustments* section should also be read before installation.

For those users who wish to do their own engineering, all sections may be useful. You may also wish to contact a **Tech Works** application engineer for assistance.

## Table of Contents

	<b>Page</b>
<b>Table of Contents</b>	<b>2</b>
<b>List of Illustrations</b>	<b>3</b>
<b>Overview</b>	<b>4</b>
<b>Functional Diagram and Explanation</b>	<b>5</b>
<b>Specifications</b>	<b>6</b>
<b>Mechanical Details</b>	<b>8</b>
<b>Front Panel Controls and Indicators</b>	<b>9</b>
<b>Rear Panel Connections</b>	<b>10</b>
<b>Simplified Block Diagram</b>	<b>12</b>
<b>Main Board Jumper Options</b>	<b>13</b>
<b>Universal Operator Microphone/Line Input</b>	<b>14</b>
<b>Remote EQ, Equalization</b>	<b>15</b>
<b>Paging Line Level Output</b>	<b>15</b>
<b>Monitoring Line Level Output</b>	<b>15</b>
<b>Call Tone Control</b>	<b>16</b>
<b>Level and Reach Setup and Adjustment</b>	<b>17</b>
<b>Paging Control</b>	<b>18</b>
<b>Integrated Systems Solutions</b>	<b>19</b>
<b>Operator “Reach”, Stepped Control</b>	<b>21</b>
<b>Application Templates</b>	<b>23</b>
<b>Mounting Options</b>	<b>31</b>
<b>Accessories</b>	<b>32</b>

---

---

## List of Illustrations:

	Page
Functional Diagram	5
Mechanical Drawings	8
Front View	9
Rear View	10, 11, & 19
Simplified Block Diagram	12
PCB Jumper Locations	13
Audio Chain Block Diagram	17
Integrated System Block Diagram	19
Operator Reach Controls, Stepped Buttons	21
Basic Two Station Template	23
Basic Prison Intercom Setup	24
Basic Prison/PLC Interface Applications	25
Multi-Master Prison/PLC Intercom	26
Fiber Optic Cable Remote Audio	27
VOIP Interface to Remote Prison Cells	28
Dukane / Rauland Replacement	29
Intercom with Recording and Paging	30
ICA-202D-WM1 Single Wall Mount	31
ICA-202D-WM2 Dual Wall Mount	31
ICA-202D-RM1 Rack Mount	31
ICA-202D-RM2 Rack Mount	31
Accessories	32

---

---

## Overview:

The ICA-202D is the audio heart of integrated services communications systems.

The ICA-202D is designed with the System Integrator in mind. The logic interface will function well in a simple two-station setup. However, its strength is a robust logic interface that is ideal for remote control from an external source such as a PLC, or computer, making integration into larger systems easy.

The ICA-202D has jumpers and digital switches for application configuration. Once the settings are determined, they may be set at the Factory, or in the Integrators Shop. Similar installations use the same settings, so cloning additional ICA-202D's is simple. Since all critical settings are predetermined, field setup is very easy

The ICA-202D has an External Stepped Control, which allows the Operator to eavesdrop on conversations not intended for communication, and easily return to "Normal Communications" settings. An audio limiter assures that even at the most sensitive settings, the Operator speaker will never be overloaded.

Configuration Templates support common applications. If there is not a template for your application, give us a call; we will be pleased to assist you to configure the ICA-202D into your design.

The audio quality of the ICA-202D is superb. Noise and distortion are very low. Selectable equalization optimizes voice communications. The Automatic Level Control assures optimum performance, the audio level remains constant over a wide dynamic input range. The user may wander throughout the room and still be heard at a nearly constant level.

The ICA-202D features true 25-Volt audio outputs, with excellent features for two-way communications. 20 Watts of reserve output power allows for All-Call and Paging without the use of auxiliary amplifiers, greatly simplifying systems design and reducing overall cost.

The ICA-202D features an integrated Call Tone and selectable Privacy Tone. These signals are adjustable, independent of the audio communications settings.

Line level transformer isolated outputs are provided for Monitoring, or Paging. The Monitoring Output has each side (Jumper Selectable) of the conversation mixed to a single output ideal for recording. The Paging Output is only present when the Page Switch is active, eliminating the need for an external relay.

Modular Construction makes the ICA-202D ideal for integrated designs. The unit is small; mounting is flexible and easy. Power is from a Universal Plug-in DC power adapter or screw terminals for connection of any regulated 24VDC-2A Power Supply. All I/O is through Euro-Style connectorized barrier strips. Unit is intended to use with class 2 power source.

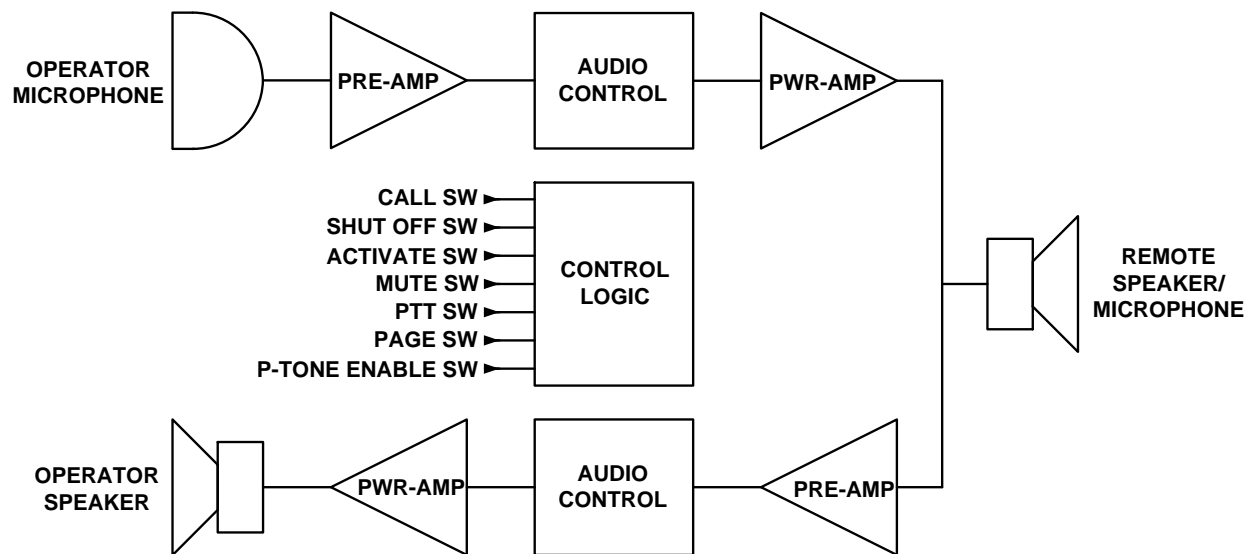

**ICA-202D Functional Diagram**

Each channel has its own audio control section, which provides Automatic Gain Control, Amplifier Muting, and other functions.

The ICA-202D is configured for Remote Station(s) to be a 25-Volt speaker. The Operator has a separate microphone and speaker.

The Logic Control section provides for complete control of the audio functions. A muting input is provided to mask station switchover noise.

Call, Privacy, and Paging Pre-announce Tones are included to simplify the external systems design.

---

---

## Specifications

### General:

Dual Channel Universal Audio Intercom Amplifier  
Inputs: R.F. and static electricity protected  
Outputs: short circuit protected  
Frequency Response: 250 Hz to 10 KHz  
20-Watts RMS Sine Wave output, 25 Volts (Balanced)  
Distortion at full voltage output < 1% T.H.D.  
Power Supply Required: 24 Volts DC @ 2.2 Amps for full rated output  
Unit is intended to use with class 2 power source

### Operator Microphone/Line Universal Input:

2000 Ohms Balanced  
As Microphone -70dBm minimum input for full rated output  
Selectable Equalization, 3 settings optimized for voice communication  
Phantom Power, short circuit protected (23 Volts, Current limited @ 9 MA)  
As Line Input, -25dBm to + 20dBm

### Remote Microphone (Also used as the Remote Speaker) Input:

1000 Ohms Balanced  
-80dBm minimum input for full rated output  
Selectable Equalization, 3 settings optimized for voice communication

### Operator Speaker Output:

Balanced  
25-Volts, Built out with 66 Ohms  
Operator Speaker, 2.25-Watts @ 45 Ohms  
Or 25-Volt Speaker tapped at ~2 Watts (See page 15)

### Remote Speaker Output:

Balanced  
25-Volts, 20-Watts (Maximum)

### Automatic Level Control:

Operator and Remote  
Greater than 40dB Automatic level accommodation  
Fast Attack, <10 mS  
Feed Forward Control, no 'Pumping'  
Adjustable 'Reach' (Sensitivity)

---

---

**Paging Line Level Output:**

600-Ohm, Balanced, Transformer Coupled  
Processed by Automatic Level Control, for ~0dBm output  
Operator Microphone, Keyed by Page Switch

**(Recording) Line Level Output:**

600-Ohm, Balanced, Transformer Coupled  
Processed by Automatic Level Control, for ~0dBm output  
Active Channel, Operator Microphone, and/or Remote *Speaker-Microphone*

**Call Tone:**

Uses Operator Speaker  
Selectable, Edge or Level Triggered  
Latched, of Momentary Control  
Adjustable Level  
Selectable Tone Character: Constant; Intermittent; Warble

**Privacy Alert Tone:**

Uses Remote Speaker  
Enabled by Switch Input  
Two hundred-millisecond tone burst  
Privacy Alert Tone on Activation  
Periodic Privacy Alert Tone, if Eavesdropping  
Adjustable Level

**Paging Pre-Announce Alert Tone:**

Uses Paging Line Level Output  
Selectable: Enable, Disable  
Two hundred-millisecond tone burst  
Keyed when Paging Switch is activated  
Adjustable Level

## Mechanical and Electrical

1U, Half Rack, 8.60" X 1.75" X 6.00"

Mounting Options: Table-Top; Under Counter; Rack

Approximately 3 lbs

Modular aluminum and steel enclosure

Euro-Style connectorized barrier strips

24 Volts D.C. 24-Watts Maximum, 50 Watts

Unit is intended to use with class 2 power source

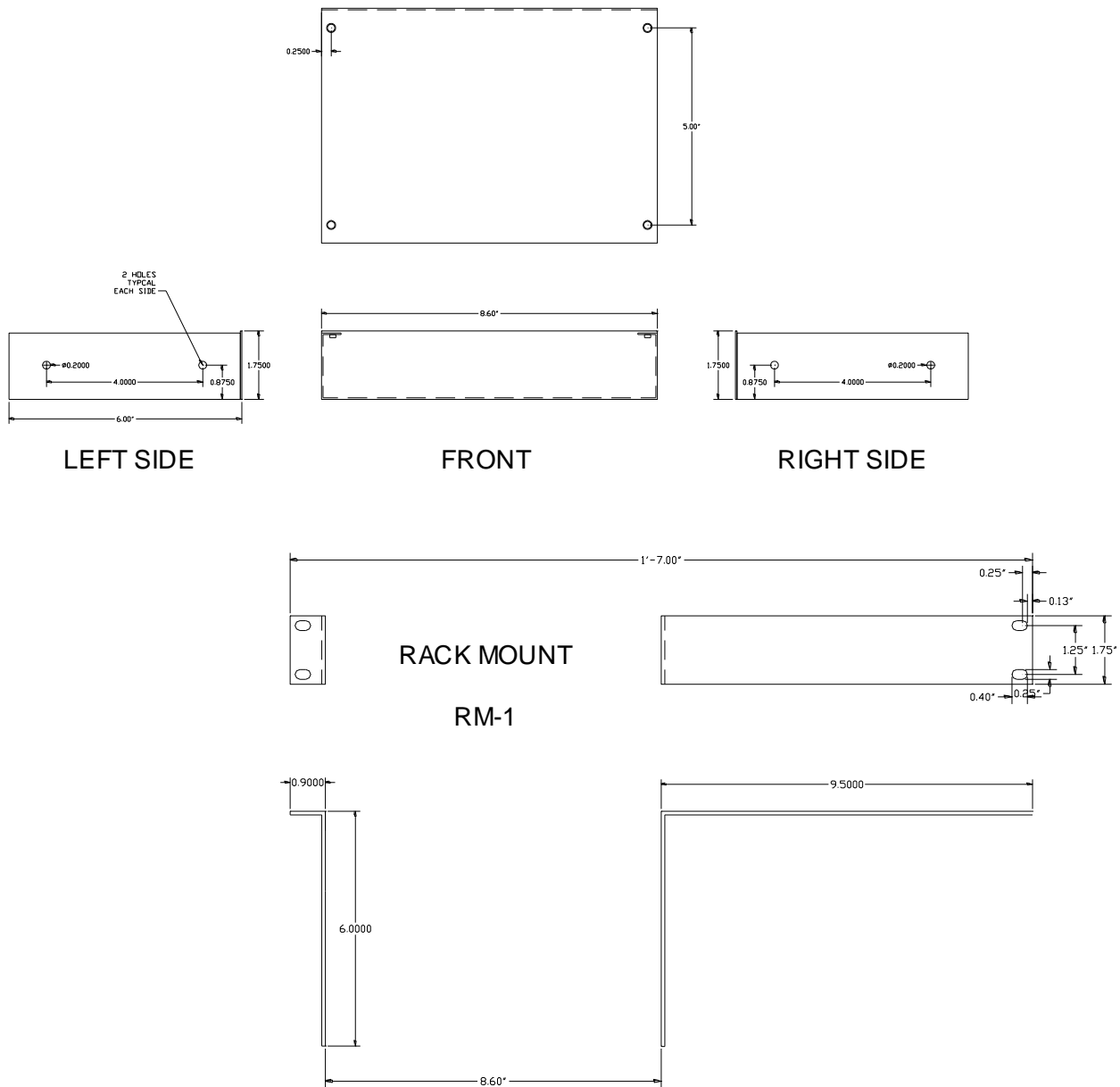

---

---

## FRONT PANEL CONTROLS AND INDICATORS



### Front Panel Audio Controls:

#### Operator 'Reach' (Remote Microphone Gain)

16 Position Switch, 3dB/step

Sets preamplifier sensitivity for Normal Microphone input level

#### Remote 'Reach' (Operator Microphone Gain)

16 Position Switch, 3dB/step

Sets preamplifier sensitivity for Normal Microphone input level

### Front Panel Indicators:

#### Power

Off, when no power

Green when operating normally

#### Operator Active

Green when Operator Listening

#### Operator Reach (Remote Microphone Level)

Off when Microphone not Active

Green when Microphone Active

Flashes Red when Audio is Present (Threshold of Limiting)

#### Page (From Operator Microphone)

Green when Operator is 'Paging'

#### Remote Active

Green when Remote Listening

#### Remote Reach (Operator Microphone Level)

Off when Microphone not Active

Green when Microphone Active

Flashes Red when Audio is Present (Threshold of Limiting)

## REAR PANEL CONNECTIONS

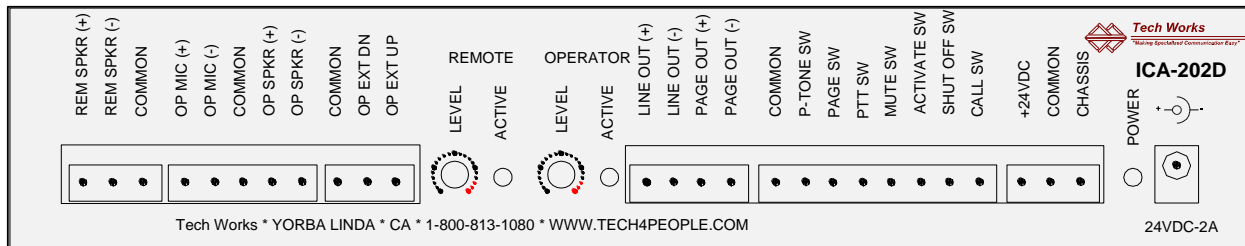

### Logic Control Inputs:

#### Common sensing for Switches, or PLC

**Privacy Tone Enable Sw** - Active low, momentary, or sustained  
Enables Privacy Tone burst temporarily forcing the Remote Speaker on  
The Privacy Tone is initiated when the Intercom is activated  
Or when the Intercom is un-muted  
Activation from "Push to Talk" or "Page" does not sound the Privacy Tone  
The tone burst also sounds every 18-20 seconds if there is continuous listening

**Page Sw** - Active low (Same functions as PTT)  
Causes "Page Out" output to carry the Operator Microphone audio signal  
This Page Switch Input is diode isolated, so a relay powered +24Volts may also connect to the same point (The Relay Coil must also have an Anti-Fly Wheeling Diode)

**Push to Talk (PTT) Sw** - Active Low, momentary or sustained  
Forces the Remote speaker on while depressed (Sustained)  
Cancels "Call Tone" (Jumper Option)  
Activates the Intercom if Inactive  
Does not cause the Privacy Tone to be sent

**Mute Sw** (Highest Priority) – Active Low, momentary, or sustained  
Causes both channels to mute  
Does not change the state Active or Call Flip-Flops  
Sounds Privacy Tone when un-muting (Jumper Option)

**Activate Sw** - Active Low, momentary, or sustained  
Overrides "Shut Off"  
Quiescent state, Operator on  
Cancels Call Tone (Jumper Option)  
Cause Privacy Tone to be sent (Jumper Option)

**Shutoff Sw** (Lowest Priority) - Active low, momentary, or sustained, see below  
Disables both Operator and Remote Speakers  
(Overridden by "Activate", "Push to Talk", or "Page")

**Call Sw** - Active low, momentary, or sustained  
Causes "Call Tone" to be sent to the Operator speaker

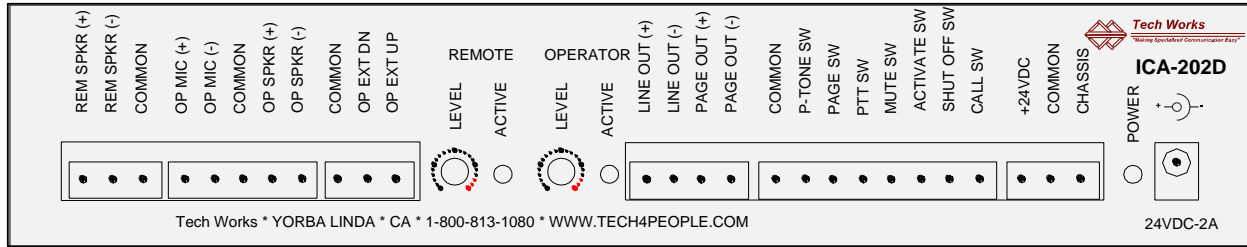

### Back Panel Audio Controls:

#### Remote Speaker 'Level'

Control TrimPot; set for desired listening level

#### Operator Speaker 'Level'

Control TrimPot; set for desired listening level

### Back Panel Indicators:

#### Power

Off, when no power  
Green when operating normally

**Remote 'Active'**, Green when Remote Listening (Operator Talking)

**Operator 'Active'**, Green when Operator Listening

### External Operator (Extended) Reach Control:

Two Active low, momentary, (Or sustained) inputs  
16 Position stepped control, with "UP" and "DN" pulsed inputs  
"UP" extends "Reach" (Increases Microphone Sensitivity above Normal level)  
"DN" returns "Reach" toward Normal sensitivity  
**(If not used, the ICA-202D powers up to the "Normal" setting)**

# Simplified Block Diagram

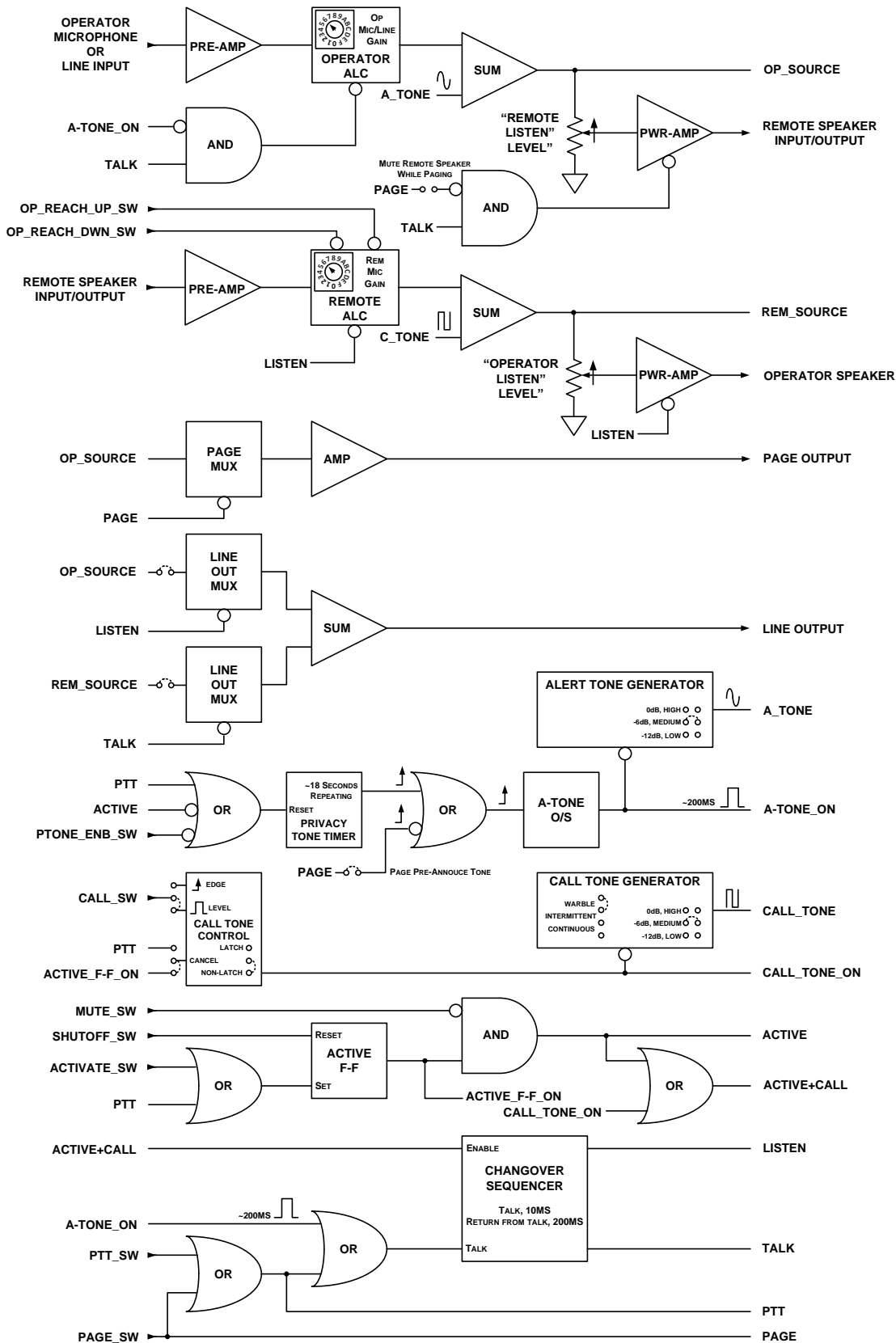

**Jumper Options (Refer to the Block Diagram for Jumper Function)**

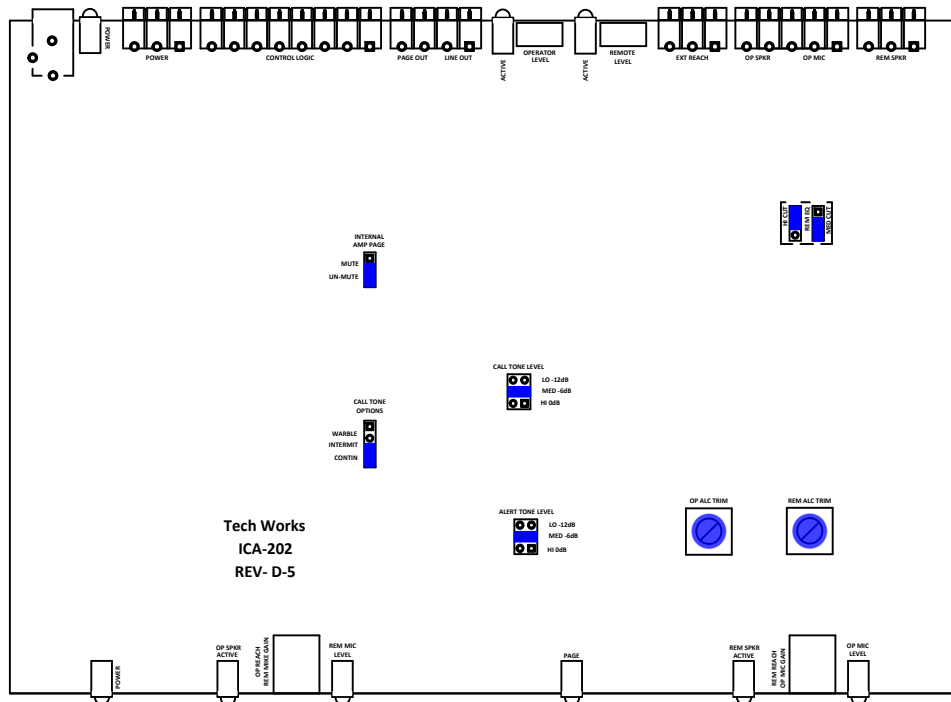

**ICA-202D-5 PCB Jumper Locations**

Factory Default Positions Shown

## Universal Operator Microphone/Line Input

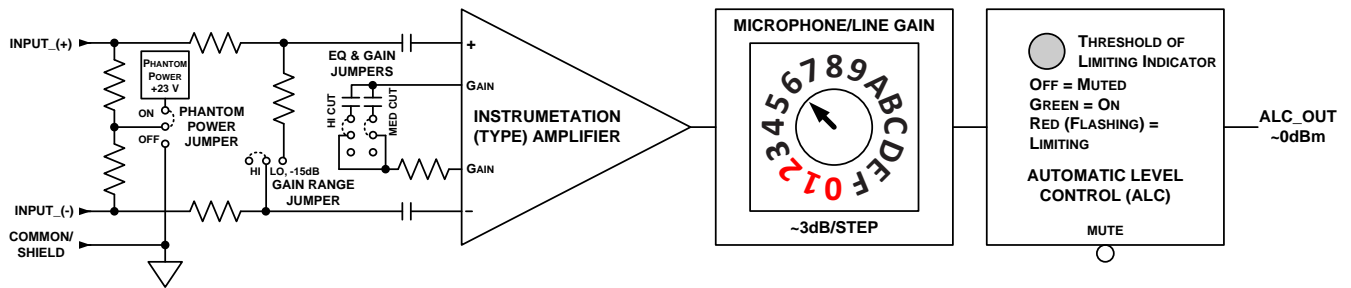

This input can accommodate a wide range Microphone or Line inputs  
 The Microphone Sensitivity is adjustable with the 16 Position Rotary Switch  
 With ~3db/Step for a 45 dB range  
 By using the Gain Switch, and Jumper options the total Range is -65dB to +20dB

The Signal is processed with an ALC, to assure the Output never exceeds 0dBm  
 Indicators allow the Microphone Gain to be adjusted to the optimal level

### Phantom Power:

Terminating Resistors referenced to +23Volts, Current limited @ 7MA ,     ON  
 Terminating Resistors connected to Common,                                     OFF

### Gain Range:

Input Gain reduced 15dB,     LO  
 Full Gain,                                     HI

### EQ Jumpers (Two):

Both Jumpers, upper position, lowest frequency Roll-off  
 (Used with most gooseneck and Hanging microphones)

Only MED CUT Jumper Upper Position, Medium frequency Roll-off  
 (Used with most flush mounted microphones)

Only HI CUT Jumper Upper Position, Highest frequency Roll-off  
 (Used with most Speakers used as a microphone)

Both Jumpers Lower Position, (Line Input)  
 ~170Hz Roll-off, Sensitivity reduced to -25dBm input for full Output

### Notes:

**If the Limiting occurs with the Stepped Gain Control on "0", "1" or "2"**  
 There is insufficient Headroom, use the "LO" Gain Range

**For a Balanced Line Level Input** the LO Gain Position is also used  
 The Accommodation Range for full output is ~ -10dBm to +20dBm (With 10dB of Headroom)

---

---

## Remote EQ, Equalization:

EQ Jumpers (Two):

Both Jumpers, upper position, lowest frequency Roll-off  
(Used with most gooseneck and Hanging microphones)

Only MED CUT Jumper Upper Position, Medium frequency Roll-off  
(Used with most flush mounted microphones)

Only HI CUT Jumper Upper Position, Highest frequency Roll-off  
(Used with most Speakers used as a microphone)

Both Jumpers Lower Position, (Line Input)  
~170Hz Roll-off, Sensitivity reduced to -25dBm input for full Output

## Paging Line Level Output:

The Operator Microphone Output is routed to the Paging Line Level Output when the Page Switch is active

The Internal Remote Amplifier may be active or muted during a Page

Remote Speaker Carries Page	Un-Mute
Remote Speaker Muted during Page	Muted

A 200mS Pre-Announce Tone burst may precede the Page

Send Pre-Announce Tone	ON
No Pre-Announce Tone	OFF

Pre-Announce Tone Level

0dBm (Same level as Communications)	HI
-6dB	MED
-12dB	LO

## Monitoring Line Level Output:

Jumpers to select the Signal Sources

**Operator** *Speaker sources, Remote Microphone and Call Tone*

Routed	ON
Not Routed	OFF

**Remote** *Speaker sources, Operator Microphone, Privacy, and Paging Pre-Announce, Tones*

Routed	ON
Not Routed	OFF

---

---

## Call Tone Control

The three sets of Call Tone jumpers accommodate many control schemes

The Call Tone sounds through the Operator Speaker

The Call Switch may be internally latched (Jumper Option) using the internal register  
Or the Call signal may be controlled by an External Controller (Jumper Option)

When the external controller is used the state of the Intercom is ignored, and the Call signal sounds whenever the 'Call Switch' is low (The Jumper selection for Level Triggered is used)

If the Call Switch request is latched (Jumper Option),  
only a momentary closure of the Call switch is required.

When the Intercom becomes Active (Jumper Option), the Call Tone is canceled.  
If the Call Switch is pressed while the Intercom is Active it is ignored.

When the PTT Switch is pressed (Jumper Option), the Call Tone is canceled.  
If the Call Switch is pressed while the Intercom is Active the Call Tone will sound.

When the Call Switch is 'edge triggered' (Jumper Option) the normal setting, the Call Tone switch must be released and re-pushed while the intercom is inactive (Jumper Option) to cause a new call tone to sound. This option is helpful if the Remote Station user is in a panic, and will not release the Call Switch.

When the Call Switch is 'level triggered' (Jumper Option), the Call Tone will sound whenever the Call Tone switch is closed and the intercom becomes inactive (Jumper Option)

### Call Tone Configuration Jumpers:

Edge Triggered Call Tone	ON
Level Triggered Call Tone	OFF

Momentary control by external PLC, <i>Edge Trigger=OFF</i>	Non-Latched
Use the internal Registers to sustain the call	Latched

*When Internal Register Sustains Call (No affect in Non-Latched)*

Call Cancelled by	ACTIVE State
Call Cancelled by	PTT Switch

Call Tone Level	
0dBm (Same level as Communications)	HI
-6dB	MED
-12dB	LO Setup Adjustments

---

---

## Level and Reach Setup and Adjustment:

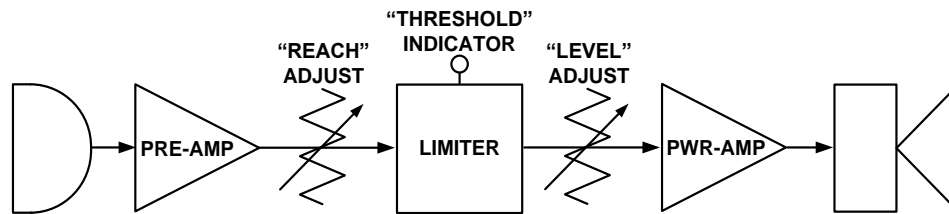

**ICA-202D Audio Chain Block Diagram**

The ICA-202D has two adjustments for the audio, for each Channel, 'Reach' and 'Level'. Once they are setup, these settings should never need to be adjusted by the user.

The Limiter Threshold is fixed; no matter how great the input level becomes the output level will not exceed the 'Limiting Level' (0dBm)

The 'Reach' Control sets the microphone gain. The greater the 'Reach' the fainter the input level that can be heard, and of course the greater the background noise!

The 'Reach' is set for normal communications, to be approximately 6 dB into limiting. This allows the user to move throughout the room, while maintaining an almost constant output level from the limiter

Setup is accomplished with the use of an Assistant (best) or a Radio, or other sound source. The sound source should be set at the normal expected level, and position, of the User

Setup each direction, one at a time:

For both Channels, (If the External Reach Control is not being used):

First setup the "Reach" (Pre-limiter, Microphone Gain)

Set the Reach Control to the minimum level, (Red dot, at 6 O'clock position).

Then advance the control CW, one step at a time, until the "Threshold" indicator just flashes.

Then advance control two more clicks (6dB into limiting)

Then set the (Post-limiter, Power Amplifier) Speaker "Level"

Advance the "Level" control CW for the desired listening level

*It is not recommended setting the level control into the red dots*

*If a greater output level is desired, a higher wattage speaker tap is recommend*

***If the "External Reach Control" is used, it must first be set to the "Normal" Setting  
This can be done by Power Cycling the ICA-202D, or by pressing (And Holding) the  
"Down/Normal" Switch for approximately 4 Seconds***

Then adjust the "Operator Reach" (Pre-limiter, Microphone Gain to the "Normal" setting)

Set the Reach Control to the minimum level, (Red dot, at 6 O'clock position).

Then advance the control CW, one step at a time, until the "Threshold" indicator just flashes

*Do not advance the control beyond that point*

Next, set the (Post-limiter, Power Amplifier) Speaker "Level"

Advance the "Level" control CW for the desired listening level

---

---

### Call Tone Level:

The Call Tone signal comes through the Operator's speaker.  
This adjustment should be made after Communications levels are set.  
The Call Tone level has three Steps, "HI", "MED", "LO"  
Setup is accomplished by activating the 'Call Tone' by pushing the 'Call' Switch.  
Select a suitable Call Tone level.

### Privacy Tone Level:

(Note: the Privacy and Page Preannounce Tones share the same "Level" setting)

The Privacy Tone signal comes through the Remote speaker.  
This adjustment should be made after Communications levels are set.  
The Privacy Tone level has three Steps, "HI", "MED", "LO"

*(The **Privacy Tone must be enabled**, "P-TONE-ENABLE" tied to COMMON)*  
Setup is accomplished by performing a sequence that causes a Privacy Tone  
First push and release the 'Shut Off' Switch, then push the 'Activate/On' Switch.  
The Privacy Tone will sound briefly. If your system does not have a push to 'Activate/On'  
Switch the Privacy Tone will sound briefly every 18 seconds when the Intercom is active.  
Select a suitable Privacy Tone level.

### Page Pre-announce Tone Level:

(Note: the Privacy and Page Preannounce Tones share the same "Level" setting)

The Page Pre-announce Tone comes through the Page Line Level Output  
The Privacy Tone level has three Steps, "HI", "MED", "LO"

*The **Page Preannounce Tone**, (Jumper Option) **must be "ON"***  
Press the Page Switch; the Preannounce tone will sound  
Select a suitable Page Pre-announce Tone Level

### Paging Control:

Paging is Handled similarly to PTT, with additional Jumper Options:

There is a 200ms Pre-Announce Tone	ON
There is No Pre-Announce Tone	OFF

The (Internal) Remote Speaker Amplifier is Disabled during a Page	MUTE
The (Internal) Remote Speaker Amplifier is Enabled during a Page	UNMUTE

## Integrated System Solutions

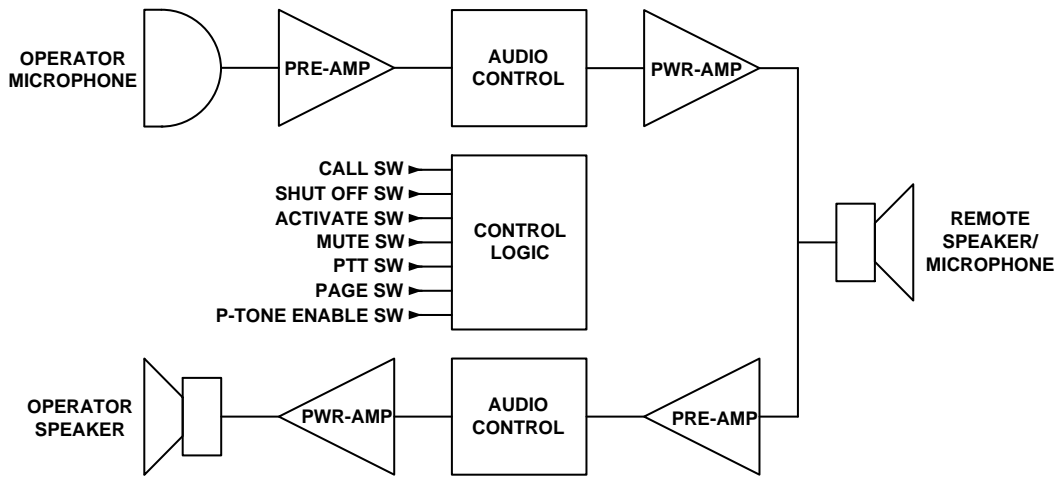

The ICA-202D provides a complete audio and logical interface for an integrated systems solution. In most applications the Remote Speaker is accessed through a Switching Matrix, controlled by a computer, or PLC.

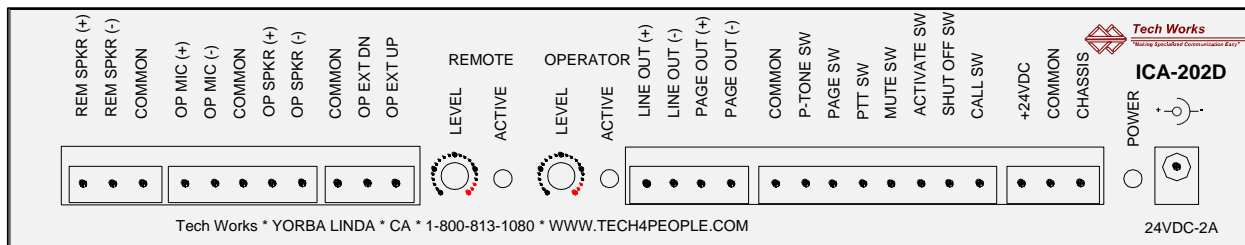

The Operator microphone may be either a Dynamic, or Condenser type.  
 The Microphone is balanced and may be Phantom Powered.  
 If a flush mounted microphone is required, the Tech Works HM-1 is recommended

The Operator Speaker output is optimized for 100-Ohm voice coil speakers.  
 The Maximum Output is 25-Volts. Internally, the output is built out with a 66-Ohm resistance.  
 A 45-Ohm, 2.2-Watts voice coil or higher impedance is acceptable.  
 A 25-Volt speaker tapped at 5 watts or less is also acceptable.

---

---

The Remote Speaker(s) should be 25 Volt units, tapped at 2.5 Watts or less. Since the remote speakers are also used as microphones, all remote speakers on the system that are used for two-way communications should be similar, and be tapped the same. It is assumed that two-way communications only takes place to one remote speaker at a time.

Speakers that are only used for paging may be tapped to any power level up to 20 Watts. It is important that in any paging application that the total load not exceed 20 Watts.

The logic interface is ideal for external control with features designed to ease system integration.

The ICA-202D has two Flip-Flops, one for Activation, and the other for the Call function. These Flip-Flops are configured so that the external Control Inputs can override the internal states.

If the Shut Off input is tied to Common, Activation follows the Active input, which is ideal for external use with an external controller.

The internal Call Flip-Flop may be used, or bypassed for use by an external controller.

If the internal Call Flip-Flop is bypassed, the Call Switch input should also be set to non-edge triggered. The Call Switch input is then sustained to cause the Call Tone to Sound.

When the Internal Call Tone Flip-Flop is used several control variations are possible.

The Call input may be configured as Edge Triggered or Level Triggered. For PLC operation this determines whether the interface will respond to a Call Input that is pending when the Intercom becomes inactive. In some applications any pending call should be sounded immediately. In some systems the operator may be switching from one Station to another and not want to be annoyed by pending calls, just new calls, when the Intercom is inactive.

Calls may either be cancelled by the Intercom being Active, or only by pressing PTT. When the Active jumper option is chosen, a Call is ignored if the Operator is Listening or Talking.

When PTT jumper option is used, the Call Tone will sound even if the Operator is listening. The Call can only be cancelled by the Operator acknowledging the Call, by talking to the Remote Station.

The ICA-202D has a separate Mute input. The Mute Input affects both channels of the intercom; however, it does not change the activation state. The mute does affect the Call Flip-Flop. Mute has the highest priority. When muted, all signals to both Speakers are squelched. The mute signal is necessary on some systems to allow the Remote Speaker to switch to a new Station without causing pops in the Operator Speaker. Mute would momentarily be employed during switching while 'Listening' or returning to the 'Listening' state.

The PTT (Push to Talk) input activates the Intercom. If the Shut Off input is tied to common, then PTT only activates the intercom while the signal is asserted.

The Page input has the same functionality as the PTT input, with added features. The internal Remote Power Amplifier may be enabled, or disabled during a page. The Operator Microphone is keyed to the Line Level Output.

---

---

The ICA-202D has a **Privacy Tone** (Enabled by a Back Panel contact). The philosophy of the Privacy tone is to alert the Remote Station that the Operator is listening. The Privacy Tone is a 200mS, 1000Hz burst.

There are three conditions that cause the Privacy Tone to be sounded:

1. When the Intercom is activated by the Activate Input (Not PTT)
2. When returning from the Muted State  
(The assumption being that a new Station has been selected)
3. After ~18-20 seconds of continuous listening

The ICA-202D has two 'Line Level Outputs' with a nominal level of 0dBm.

**Paging**, the Operator Microphone keyed by the Page Switch input (See above)

"Paging" may be preceded by a Preannounce Tone (Jumper Option)

"Paging" may also be routed to the Remote Speaker (Jumper Option)

**Monitoring**, the Operator or Remote Listening Audio (Jumper Selectable), whichever is active,

Also, if enabled and present, Call, Privacy, and Page Tone

Operator "Reach", Stepped Control, for extended "Reach" for listening to very low level audio

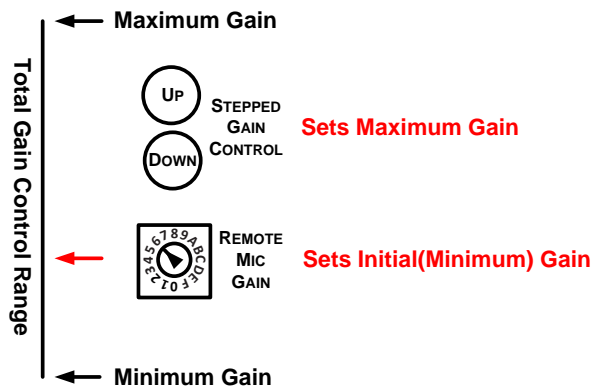

The Remote Microphone Gain is affected by two controls, the Rotary "Operator Reach Switch", and the "External Stepped Control"

Each control has 16 positions

The 'Initial (Minimum) Gain', is set by the Rotary Switch and may be increased in 3dB steps to 45dB

The Remaining Gain Range is controlled by the External Stepped Gain Control

*The External Control can always achieve Maximum Gain "Reach",*

The External Reach Control...divides the Remaining Gain Range into 16 evenly divided levels

When the Unit is Powered On, the External Control is set to Minimum

*If no External Stepped Gain Control is used...*

*Both the "Operator" and "Remote" Reach Controls work the same way*

---

---

### The Reach is stepped with external controls;

Each momentary switch closure moves the setting by one step

There are 16 Levels, with 15 Steps in between

The "Up" control increases the "Reach" (Microphone Sensitivity) above the "Normal" setting

The "Down" control decreases the "Reach"

The "Down" control has Auto-Repeat (If held for more than 1/2 second), and will return to the "Normal" setting (One step at a time) at approximately 5 Steps/second

### For PLC Applications:

The Quiescent input is an Open Circuit (Pulled internally to +6 Volts)

One Input or the other should be momentarily pulled to Common, never both at the same time

The Active (Low level) should be held 100 to 250 mS

The rest (Open Circuit) between pulses should be greater than 200mS

The "Down" Input has an Auto-Repeat function, so the "Reach" may be reset to the "Normal" setting by holding the "Down" input Active (Low level) for 4 Seconds.

There are three configurations of these controls that have practical applications:

1. The "External Stepped Reach Control" is not used  
When the ICA-202D-3 first powers up, the "External Extended Reach Control" is set to "*minimum*" gain of 0dB  
This essentially puts the "External Stepped Control" out of the circuit  
Therefore the front panel Rotary "Reach Control" has the entire range of 45dB; 3dB/step
2. Both the "External Stepped Reach Control" and the Rotary "Reach" Switch are used  
The standard setup is to set the Rotary "Reach Switch" to a "normal setting", the onset of limiting for a 'normal' speaking level at the Remote Station  
*With the "External (Extended) Stepped Reach Control", set to "minimum" of 0dB*  
As the "External Reach Control" ("minimum" gain) is advanced, the remainder of the 45dB of gain is divided into the 16 steps  
As an example, consider a setup where the Rotary Switch is set to "12 O'clock", which represents a microphone gain of ~24dB  
The remainder of the gain (24dB) is controlled by the "Extended External Stepped Reach Control" with 1.5dB/step  
In this configuration, the Rotary Switch should never be set past the 3 O'clock position  
Otherwise, very little control is available to the External Control.
3. Only the "External Stepped Reach Control" is used by an external controller PLC  
The setting of the Rotary "Reach" Switch is set to "0", (Red dot, at 6 O'clock position)  
Then the "External Stepped Reach Control" has the entire range, 45dB; 3dB/step

*Under most conditions it is recommended when using a PLC, setup '2' is used*

# Application Templates

## Basic Two-Station Intercom Setup

The application templates in this section show some of the common uses of the ICA-202D. Below is the basic wiring of the components used for a simple two station Push To Talk Intercom.

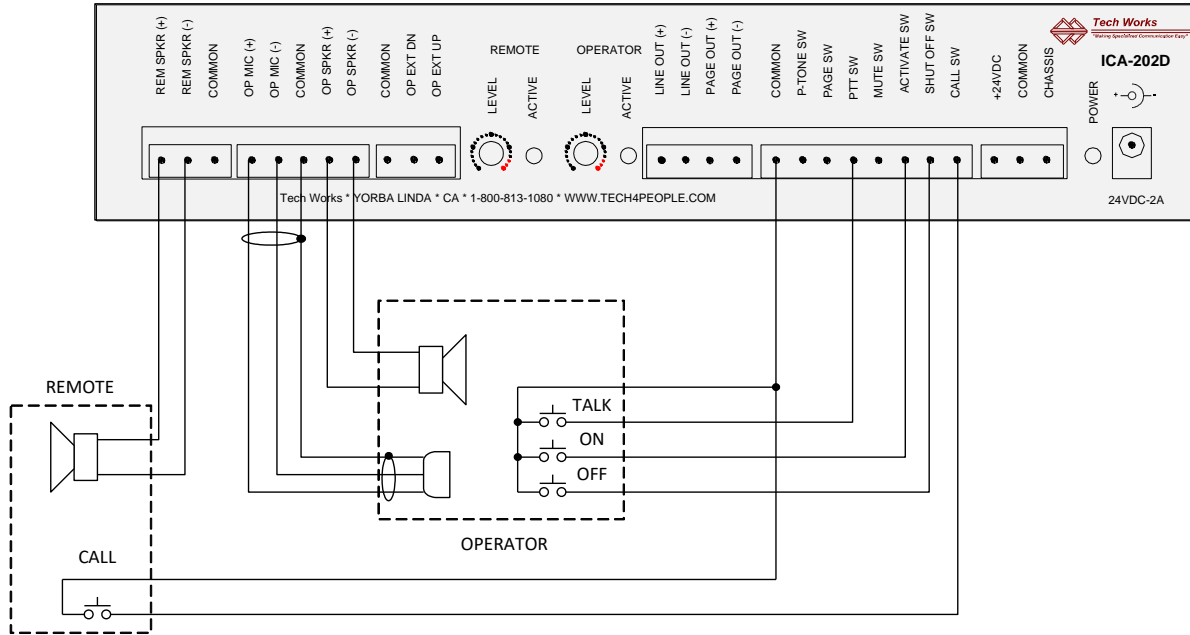

Below are the internal jumper settings for the basic intercom functions

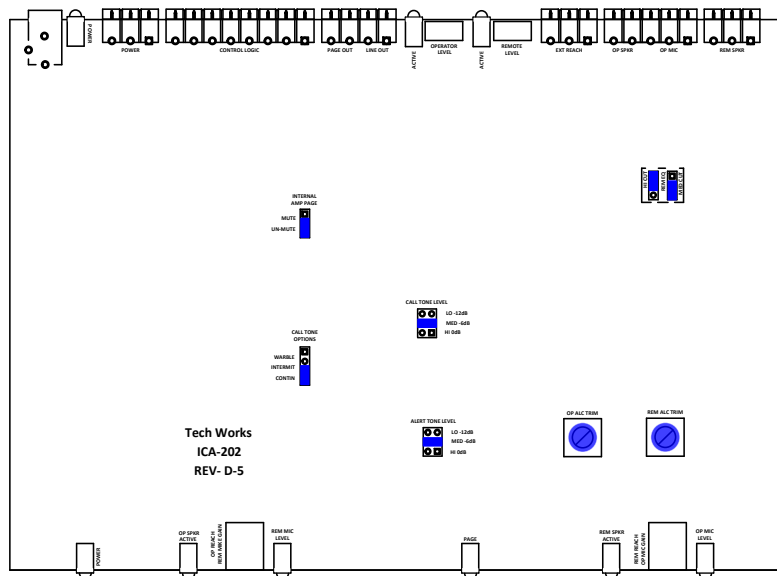

## Basic Prison Intercom Setup

Below is the basic wiring of the components used for a simple Prison Guard Intercom.

The External Reach Control allows the Guard to adjust the Sensitivity to hear low level conversations . The stepped control is pulsed to "UP" to increase sensitivity, or step "DOWN" to reduce the sensitivity. Holding the "Down" control will cause it to auto-increment to the Preset-Value

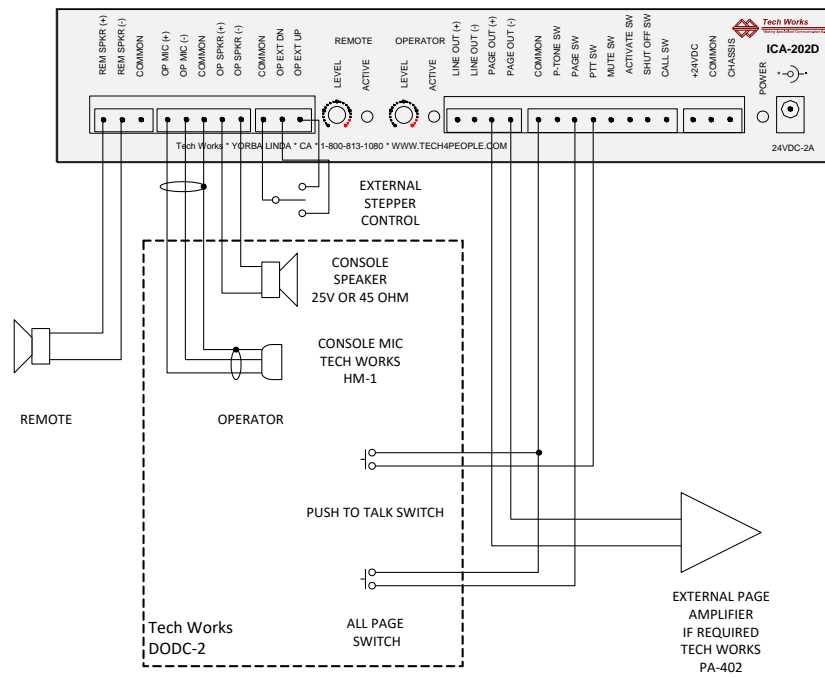

Below are the internal jumper settings for the simple Prison Guard functions

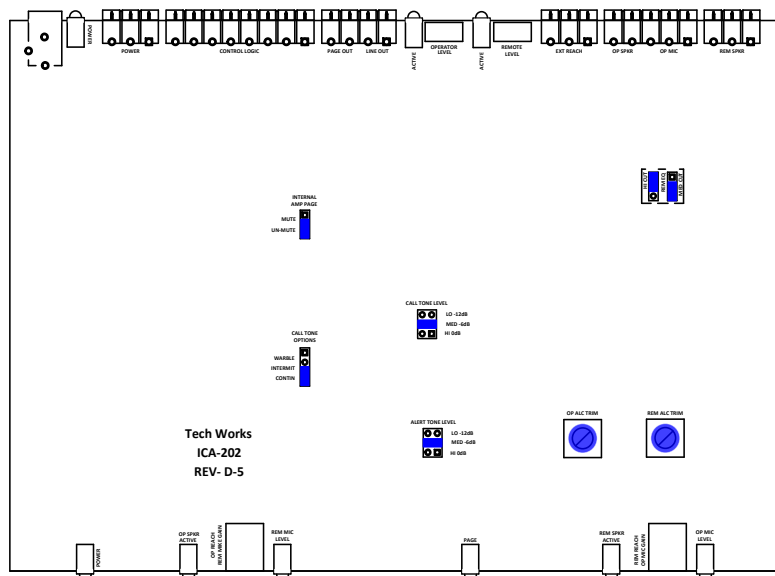

## Basic PLC Prison Intercom Setup

Below is the wiring of the components used for a Basic PLC Prison Guard Intercom.

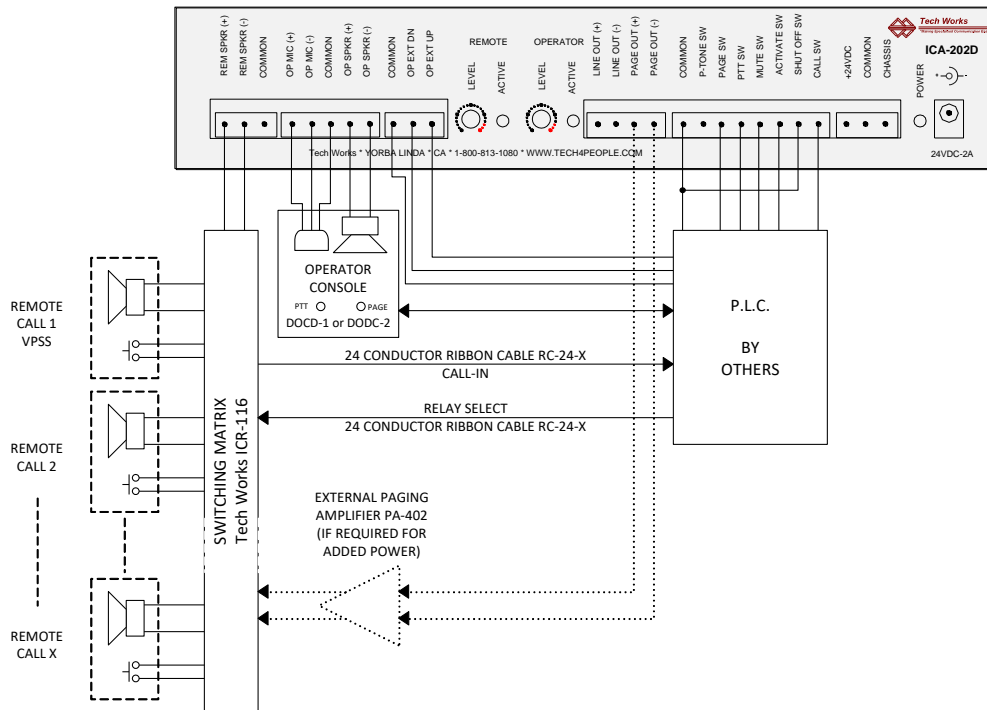

Below are the internal jumper settings for the ICA-202D when used with a PLC. Note the Edge Trigered Call Tone is set to Continous and the Internal Amp Page is set to Mute on All Page. This assumes the use of an external page amplifier.

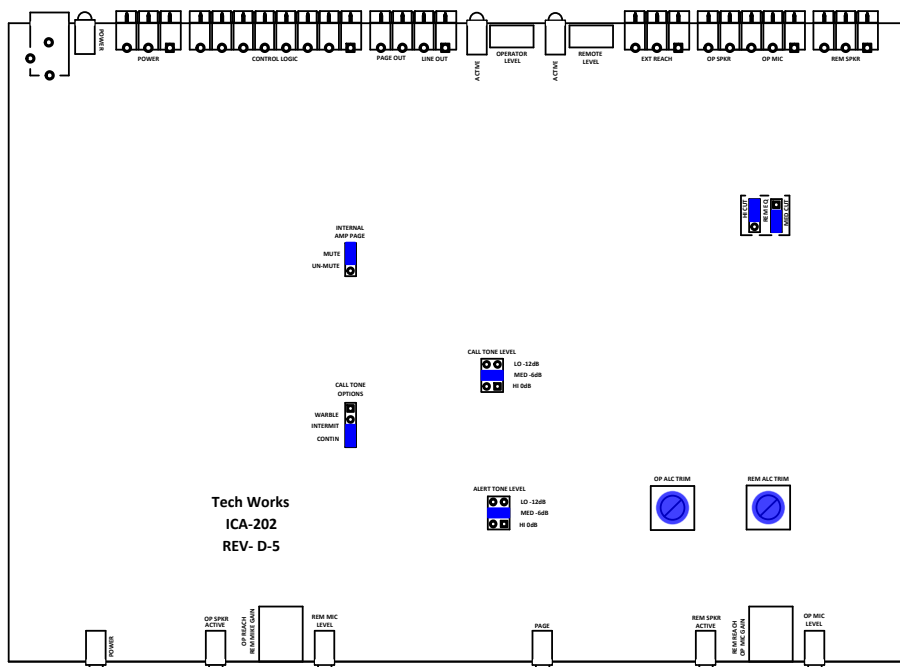

## Multi Master Prison Intercom Setup

Below is the wiring of the components used for a Multi Master Prison Guard Intercom.

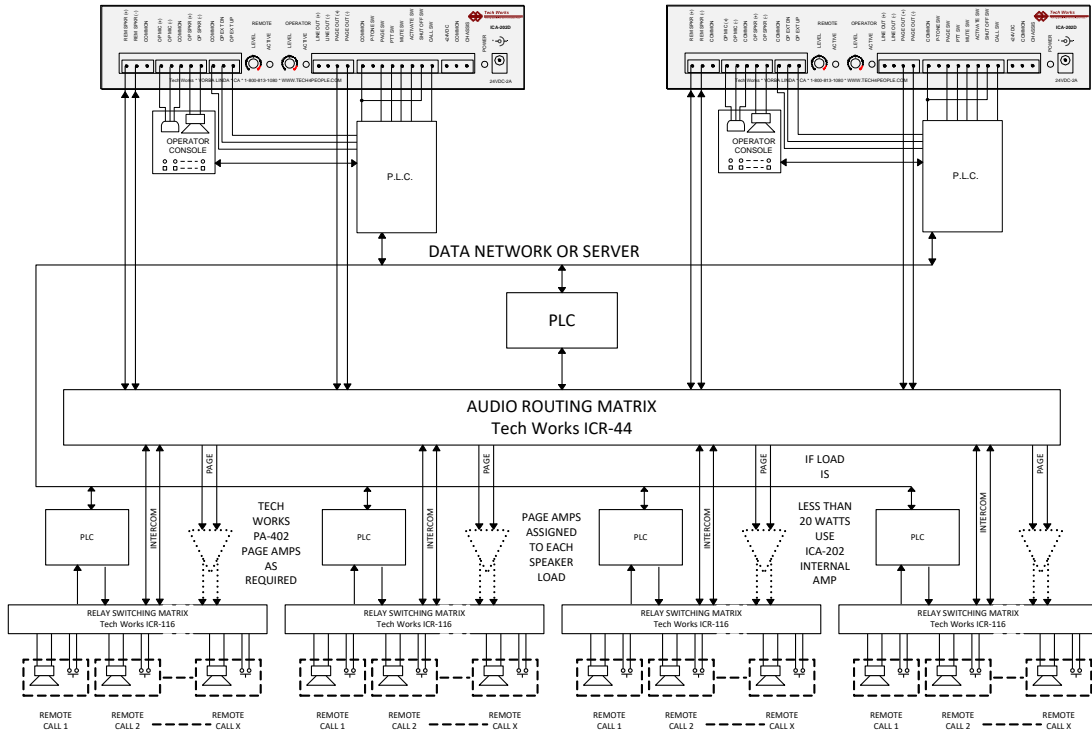

Below are the internal jumper settings for the ICA-202D when used with a PLC. Note the Edge Triggered Call Tone is set to Continuous and the Internal Amp Page is set to Mute on All Page. This assumes the use of an external page amplifier.

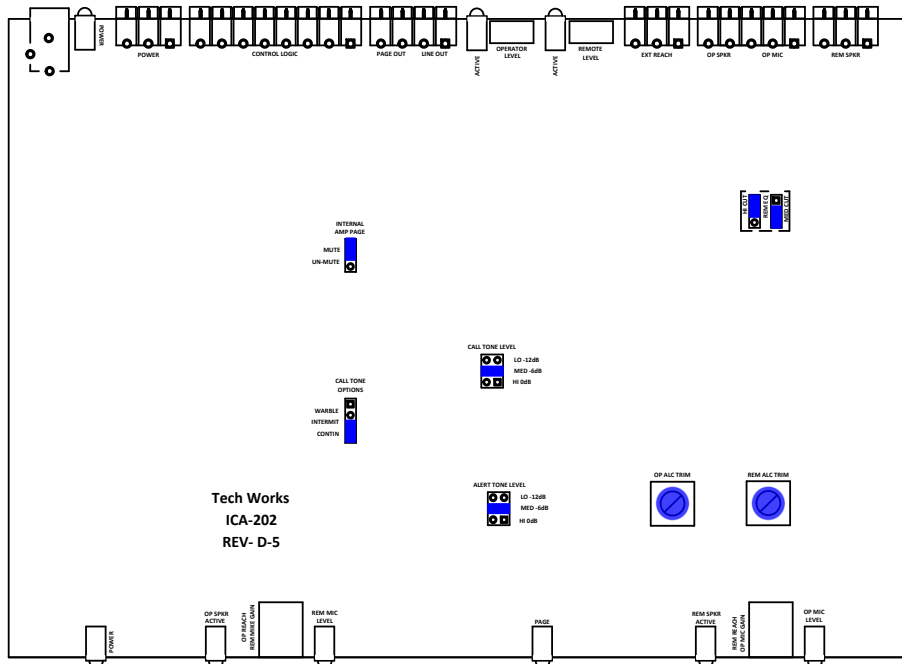

## Fiber Optic Cable Remote Audio

Sometimes the Prison wants to have the guard Operator or monitoring station mile away from the prison cells. Tech Works can help by making the audio interface to a fiber optic cable system easy.

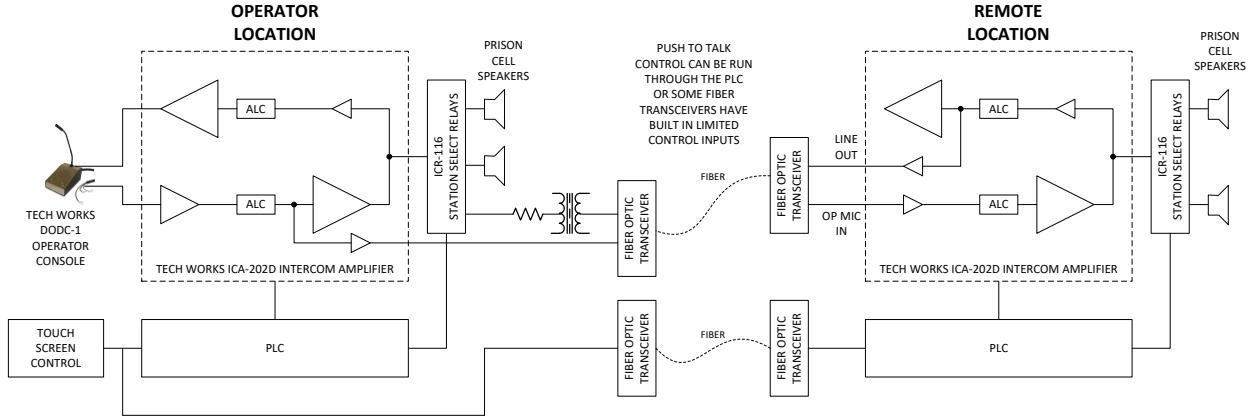

By using ICA-202D to power and control the Operator location and a second ICA-202D at the Prison Cell location the integration is done with off the shelf product in a simple installation. As shown above the Operator can talk to both Local Speakers and Remote Speakers

To interface the Operator Location to the Fiber Transceiver, an interface network is required. Below is a detail of how to build an interface for the ICA-202D Remote Speaker connection to a Line Level Fiber Transceiver using off the shelf components.

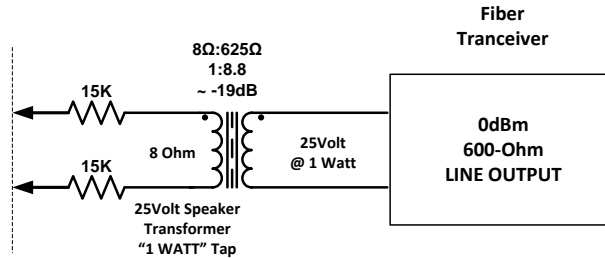

Below are the internal jumper settings for the interface shown above.

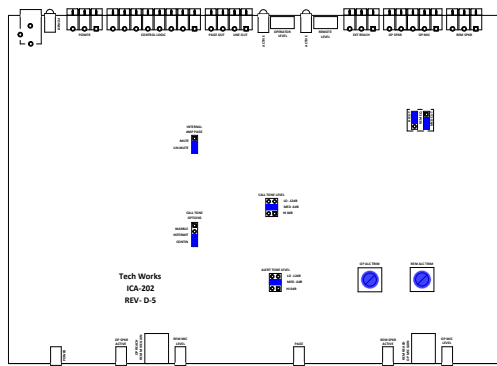

ICA-202D Operator Unit Jumpers

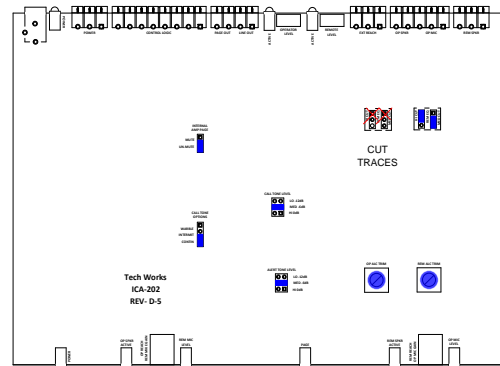

ICA-202D Remote Unit Jumpers

## VOIP Interface to Remote Prison Cells

If you want to go Voice Over IP and do a full integration to your PC control system and run the whole thing over Ethernet you can do it using the ICA-202D

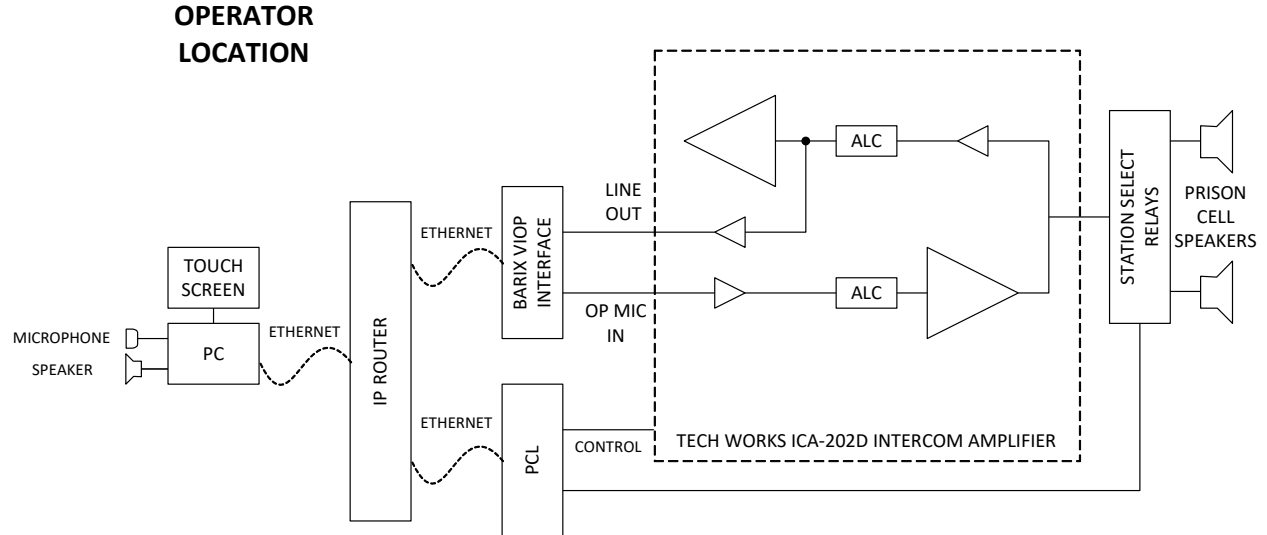

**ICA-202D MUST BE LOCATED NEAR THE STATION SELECT RELAYS**

Below are the internal jumper settings for the interface shown above.

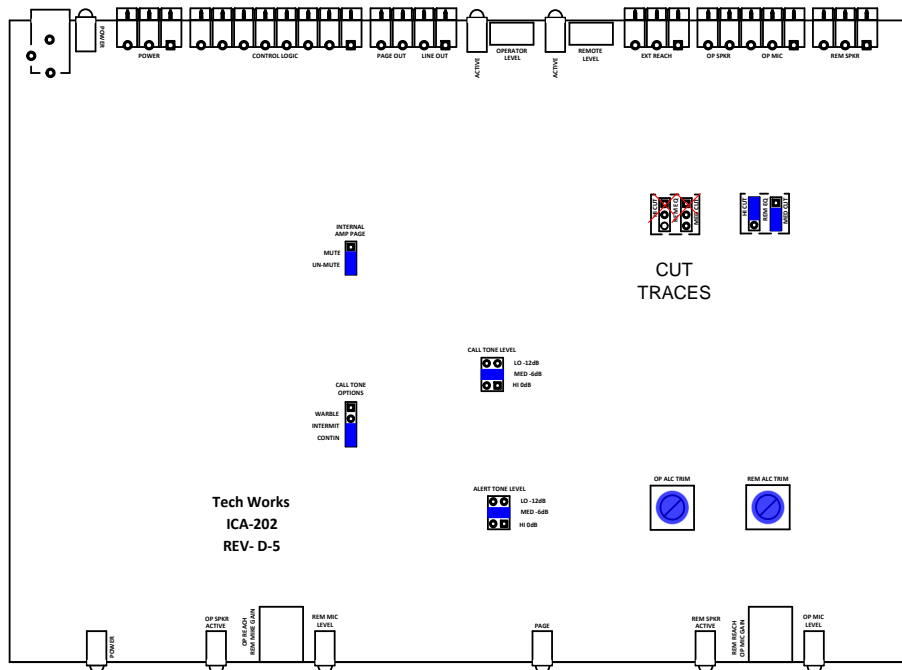

## Replacing an old Dukane or Rauland Amplifier

Below is the wiring when replacing an old Dukane or Rauland Prison Guard Intercom. Because some of these products had an internal "Page" relay that is not included with the Tech Works ICA-202D an external relay may be required to route the output of the Page Amplifier.

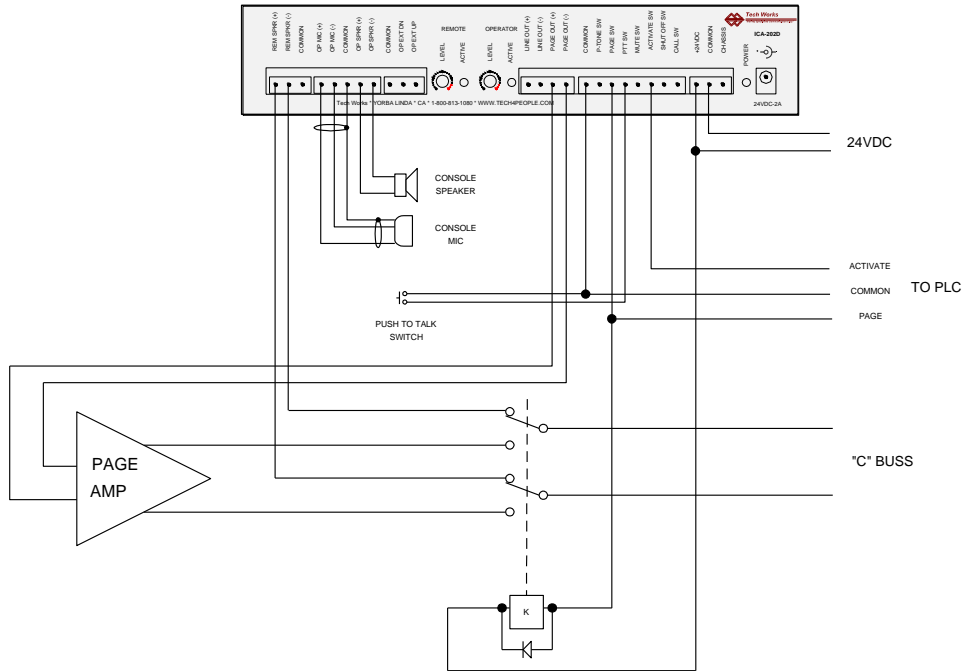

Below are the internal jumper settings for the interface shown above.

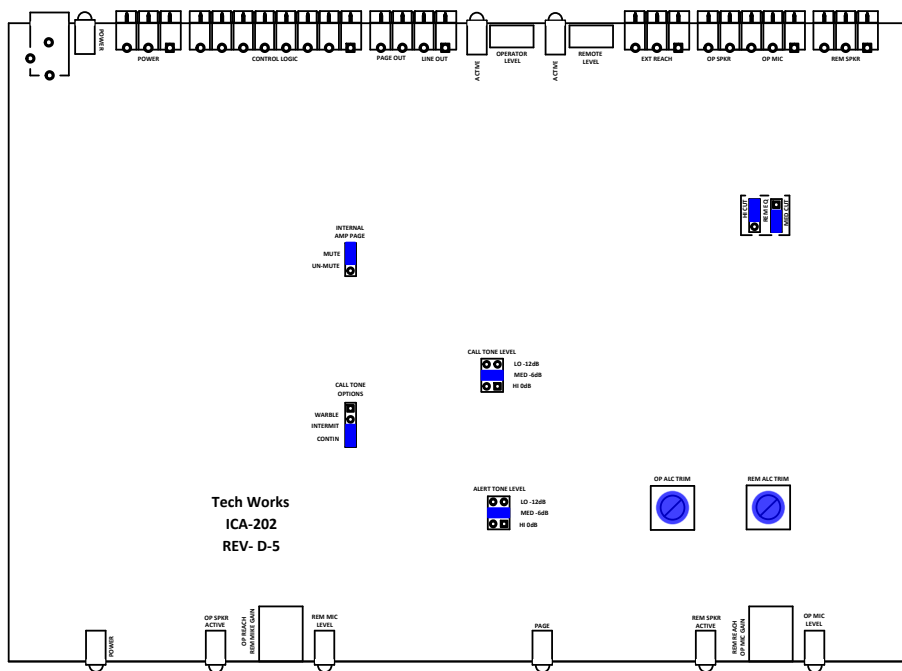

## Intercom with Recording and Paging

Below is a basic wiring diagram for intercom with a logging recorder and external paging amplifier.

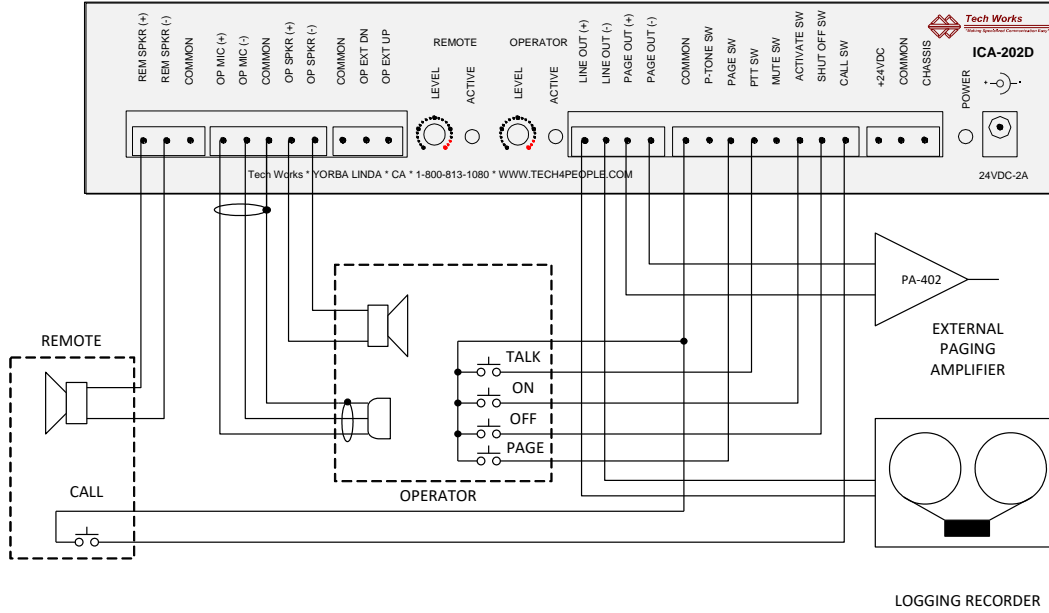

Below are the internal jumper settings.

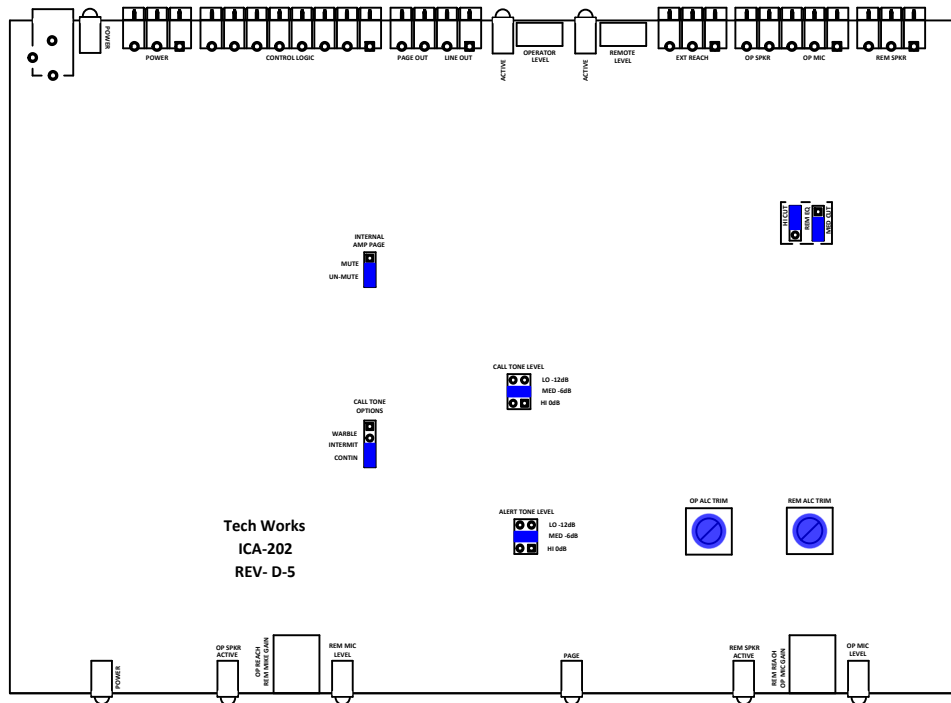

As shown, both the Operator, and Remote are Recorded. Many other configurations are available by combining this application with applications such as PLC control and others.

---

---

## Mounting Options

### Standard Desk Mount

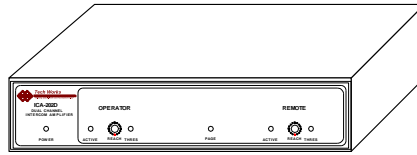

ICA-202D-DM

### Wall or Under Counter Mount

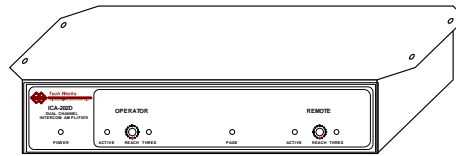

ICA-202D-WM

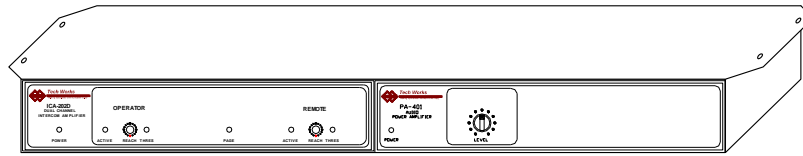

WM2 Shown with an ICA-202D and a companion PA-402

### Rack Mount Option

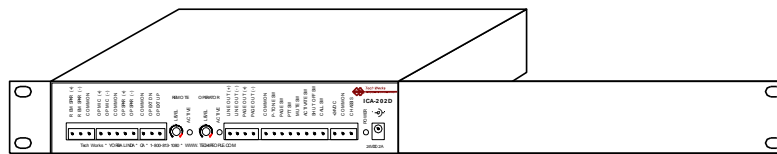

ICA-202D-RM single unit rack mounted  
All Tech Works Amplifiers can rack mount Front or Rear facing out.

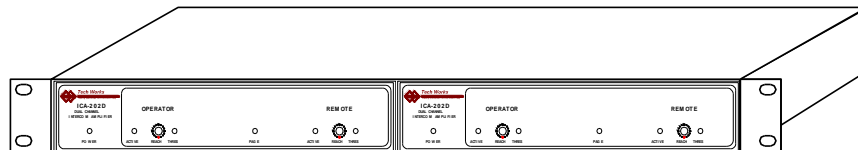

RM2 Shown with two ICA-202D units mounted in a single rack space

---

---

## Accessories



**PA-402 PAGING AMPLIFIER** - An audio amplifier designed to add Power to the ICA-202D. It delivers 40 Watts to 25 Volt loads at very low noise and distortion. Perfect for Prisons or Security applications when working in large areas or high noise.



**PSD-2437A - Power Supply 24 VDC @ 3.7 Amps** - is a regulated computer grade power supply. This unit is UL and CSA listed and includes a 6-foot removable power cord with a North American standard Edison connector.



**WM-1 & WM-2 WALL OR UNDER COUNTER MOUNT** - The ICA-202D is available with a top that provides 1" metal tabs on each side of the unit for easy attachment to either a wall or the under side of a counter. Also available in a side by side WM-2 .

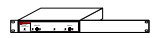

**RM-1 & RM-2 RACK MOUNT** - ICA-202D units can be rack mounted as either a single unit (RM-1), dual units (RM-2) (side by side), or as companions with accessories like the PA-401 Paging Amplifier. The rack mount is 1 rack unit (1-7/8") High by EIA 19" Wide.



**VPSS - Vandal Proof Speaker Station** - a complete call-in station with integral speaker/microphone and momentary, normally open, push-to-call button. The faceplate is a 2 gang electric box mount, 12 gage, brushed stainless steel with steel security screens mounted between the faceplate and the loudspeaker; tamper-resistant hardware is included.



**DODC-1 – Detention Operator Desk Console** – all steel console with brushed stainless steel faceplate and vandal resistant push buttons. The base is epoxy finished cold rolled steel. A professional condenser microphone provides clear high quality page and talk communication. A vandal resistant 3 inch speaker is included with steel security screens mounted between the faceplate.



**DODC-2 – Detention Operator Desk Console** – all steel console with brushed stainless steel faceplate and vandal resistant push buttons. The base is epoxy finished cold rolled steel. A Hidden condenser microphone provides clear high quality page and talk communication. A vandal resistant 3 inch speaker is included with steel security screens mounted between the faceplate.



**HM-1-SUB - Hidden Microphone Sub Assembly** - The HM-1 is an Omni-Directional Condenser Microphone with an electronically balanced preamp designed for high quality audio pick up. This is a sub assembly for flush mounting in a console.

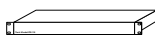

**Intercom Relay Modules** – Tech Works makes a variety of intercom Relay modules for routing audio and call in signals. The ICR-116 is 16 Relays with connector for field wiring and interconnect cables to PLC. The ICR-44 is a snap track mount 4 relay assembly designed to allow multiple master audio routing by a PLC.