



## MC-IP-Series

### Modular Communication Internet Protocol Audio Intercommunication

The MC-IP-Series is a group of audio products designed to provide very high audio quality over ethernet using Internet Protocol. Audio quality is consistent and predictable due to the implementation of Streaming VoIP with our tried-and-true audio designs and industry standard interfaces. The MC-IP provides Master to Remote communication and Master to Master Communication up to 32 Operators and 512 Remotes with a single HOST. When using MC-IP-SERVERS, 32 systems can be interconnected for a total system of 32 X 32 = 1024 Operators and 32 X 32 X 16 = 16,384 remote stations.

By using a dedicated IP network with dedicated switch, operator console, field device interface, and HOST, the MC-IP maintains quality audio with no IT setup. By plugging the units in they automatically assign IP addresses and propagate configurations based on ID settings on each device. This allows the system programmer to program the system the way it needs to be, for a specific facility, without worrying about the IT settings for proper operation. Maintenance personal, without IT skills, can swap a box and just set the box ID. As soon as it is attached to a system, the Host sets the IT parameters and downloads the unique characteristic that unit was assigned during the original system programming.

System Station hardware offers a call confirmation light and privacy alert tone for those areas that require ADA and Right to Privacy Act compliance.

The System has an API Interface, for users who would prefer to use their own Integrated Controller, for Doors, Cameras, and Communications, from a single touch screen control console.

The MC-IP Products use Standard 25-Volt Speakers, and Internet wiring.

#### BENEFITS

- Audio and Control over a Single Internet Protocol Connection
- Rugged Design
- High Quality Audio
- Self-contained electronics eliminates the need for wiring separate Modules together
- Designed Specifically for Security, Corrections and Behavioral Health applications
- Industry Standard 25-Volt remote speakers

#### Associated Equipment:

<b>MC-IP-ODC-POE</b>	Operator Desk Console w/Power Over Ethernet
<b>MC-IP-ODC-TS</b>	Touch Screen Console
<b>MC-IP-HOST</b>	Network Administrator
<b>MC-IP-SERVER</b>	Network Administrator/Router
<b>MC-IP-116</b>	16-Channel Intercom Control Module
<b>MC-IP-116-NC2</b>	16-Channel Intercom Module w/Nurse Call Features
<b>MC-IP-MSI-11</b>	Microphone/Speaker Interface
<b>MC-IP-SW-16</b>	16 port TCP/IP Switch Rack Mount
<b>MC-IP-SW-16-POE</b>	16 port TCP/IP Switch 8 w/POE, Rack Mount
<b>PA-402</b>	Paging Amplifier
<b>PS-2437B</b>	Power Supply
<b>VPSS-L</b>	Vandal-proof Speaker Station w/ Lighted Call Button
<b>MC-NC2-DL-22</b>	2 Color Dome Light
<b>MC-NC2-DL-44</b>	4 Color Dome Light
<b>MC-NC2-VPSS</b>	Vandal Proof Speaker Station
<b>MC-NC2-VP-SAS</b>	Vandal Proof Button with Light

#### Design Information:

<b>Power</b>	24V DC Power Supply (Sold Separately)
<b>Frequency Response</b>	350 – 5000Hz



# Tech Works®

"Making Specialized Communication Easy"

800-813-1080

[www.techworks-usa.com](http://www.techworks-usa.com)

10/25

# Table of Contents

System Overview.....	Page 4
System Components.....	Page 6
System Wiring and Connections .....	Page 10
Network Configuration and Setup .....	Page 10
Connecting a Laptop for programming.....	Page 10
MC-IP-HOST Connections.....	Page 11
SD Card.....	Page 11 & 13
MC-IP-SERVER Connections.....	Page 13
MC-IP-ODC Connections.....	Page 15
MC-IP-116 Connections.....	Page 16
External Paging Amplifier.....	Page 17
MC-IP-116-NC2 Connections.....	Page 18
MC-IP-MSI-11 Connections.....	Page 20
MC-IP-MSI-11 Applications.....	Page 21
MC-IP-MSI-11 Internal Jumpers.....	Page 22
MC-IP Features and Programming Options.....	Page 24
MC-IP Call Processing.....	Page 26
MC-IP Configuration Utility.....	Page 27
MC-IP Configuration File Menu.....	Page 29
MC-IP Configuration Option Menu.....	Page 29
Common Configuration Elements.....	Page 29
Interaction between ODC and another ODC or 116.....	Page 30
Station Configuration.....	Page 32
Station Edits.....	Page 33
Station Groups.....	Page 34
Console (ODC) Configuration.....	Page 35
Touch Screen Modes.....	Page 36
Paging Group configuration.....	Page 37
Station Call Edits.....	Page 38
Programming an MC-IP-MSI-11 address.....	Page 39
Programming an MC-IP-MSI-11 Configuration.....	Page 40
To Upload the Configuration.....	Page 41
To load Firmware Updates.....	Page 41
MC-IP-SERVER configuration.....	Page 42
WAN Network Settings.....	Page 43
Global Paging.....	Page 45
External control system API.....	Page 46
SERVER API.....	Page 50
Global Page API.....	Page 51
Tech Works OMRON Library .....	Page 52

# List of Illustrations:

System Diagrams.....	Page 5, 10, 11, 17, & 32
MC-IP-ODC-POE & TS.....	Page 6
MC-IP-116.....	Page 6 & 16
MC-IP-116-NC2.....	Page 7 & 18
MC-IP-MSI-11.....	Page 7 & 20
MC-IP-HOST.....	Page 7 & 11
MC-IP-SERVER.....	Page 7 & 13
MC-IP-SW-16 & 16-POE.....	Page 7
VPSS-L, MC-NC2-VPSS-2G, MC-NC2-DL-22-RW, MC-NC2-DL-44, MC-NC2-VP-SAS, VPKS-1.....	Page 8 & 19
PRO-SGM, HM-1, CRS-RC, CRS-WM.....	Page 9 & 21
CAT6-* & PC-*.....	Page 9 & 21
PS-2437B.....	Page 9
MC-IP-ODC Inside.....	Page 15
MC-IP-116 Wire.....	Page 16
External Paging Amplifier Connection.....	Page 17
MC-IP-MSI-11 Applications.....	Page 21
MC-IP-MSI-11 Jumper Guides.....	Page 22
MC-IP Call Processing Flow Chart.....	Page 26
MC-IP Configuration Utility.....	Page 27
MC-IP Configuration File Menu.....	Page 31
MC-IP Configuration Option Menu.....	Page 31
Rotary ID Switch.....	Page 30 & 35
MC-IP Station Edit Screen.....	Page 32
MC-IP Station Groups Screen.....	Page 34
MC-IP Console Configuration Screen.....	Page 35
MC-IP-ODC-TS Screens.....	Page 35 & 36
Page Group Configuration Screen.....	Page 37
Station Call Edits.....	Page 38
Upload File Screen.....	Page 27 & 41
MC-IP-SERVER Configuration Diagram.....	Page 42
MC-IP-SERVER WAN Settings.....	Page 43
MC-IP-SERVER List.....	Page 44
MC-IP-SERVER System Monitor Screen.....	Page 44
Global Paging.....	Page 45

## System Overview

Tech Works MC-IP, Modular Communication over Internet Protocol, is a group of components designed to give the highest quality audio and control while utilizing the flexibility of the Ethernet for intercom communication.

The MC-IP provides Master to Remote communication and Master to Master Communication up to 32 Operators and 512 Remotes with a simple HOST. When using MC-IP-SERVERS, 32 systems can be interconnected for a total system of  $32 \times 32 = 1024$  Operators and  $32 \times 32 \times 16 = 16,384$  remote stations.

The basic components are the MC-IP-ODC-POE, Operator Desk Console Powered Over Ethernet, the MC-IP-ODC-TS Operator Desk Console with Touch Screen, the MC-IP-116 Station Control Module, the MC-IP-116-NC2 Station Control Module with remote station Light output, and the MC-IP-HOST/SERVER. Using bi-directional streaming audio, the MC-IP connects to a dedicated switch that handles all of the communication without interruption or delays. A router is only used if there is a need to connect out of the MC network to someone else's network.

The MC-IP-HOST or SERVER stores all component profiles so when a new device is added to the system, the MC-IP-HOST/SERVER identifies the device and downloads the system profile for that component. This allows the system programmer to program the system the way it needs to be for a specific facility without worrying about the IP settings for proper operation. This also makes maintaining the system easy by allowing the installer to set up the system one time and if they ever need to swap a component there is no time lost reprogramming. This also means that the systems engineer can do all the configuration in the shop and just send the MC-IP Host out to the field pre-programmed. When components are installed in the field they are automatically added and configured without expensive personnel having to make additional visits for programming.

The MC-IP-SERVER has 2 TCP/IP connectors; one for the local Host functions connected to the local network and second to connect a local system to other systems on a second network. Each Server has a local Host port that supports  $32 \times 512$ . The second port allows this system to be identified and accessed from the WAN. One of the Servers is set up as the Server Host. When a call is to be connected between systems a request goes to the Server Host which goes to the WAN and finds the other Server and checks to see if the station is available, if it is, the call is connected between Station A on Server A and Station B on Server B. All station characteristics are stored on each local Host.

The MC-IP can be a complete solution including its own touch screen and other user interface devices or it can be controlled by some other system, like a door or camera control system, using API commands. The API commands and communication settings are described in the "*External control system API*" Section of this manual. MC-IP-HOST is designed for two points of access (Ports) from the control system to the MC-IP-HOST, NOT for multiple touchscreens all accessing control to the HOST separately (i.e., multiple touch screen IP addresses). If multiple IP access to the MC-IP is a requirement of your system design, we can offer the MC-IP-SERVER. Where the HOST can support 2 "ports" for external touch screen computers from control systems, each SERVER can support 32 ports and 32 SERVERS can be interconnected. The SERVER also acts as a router for communication between multiple MC-IP systems.

Once the system is complete, the MC-IP-HOST/SERVER sits on the network waiting for command requests such as connections of a console to a remote. The MC-IP-HOST/SERVER processes the request and then gets out of the way to allow the communication to proceed.

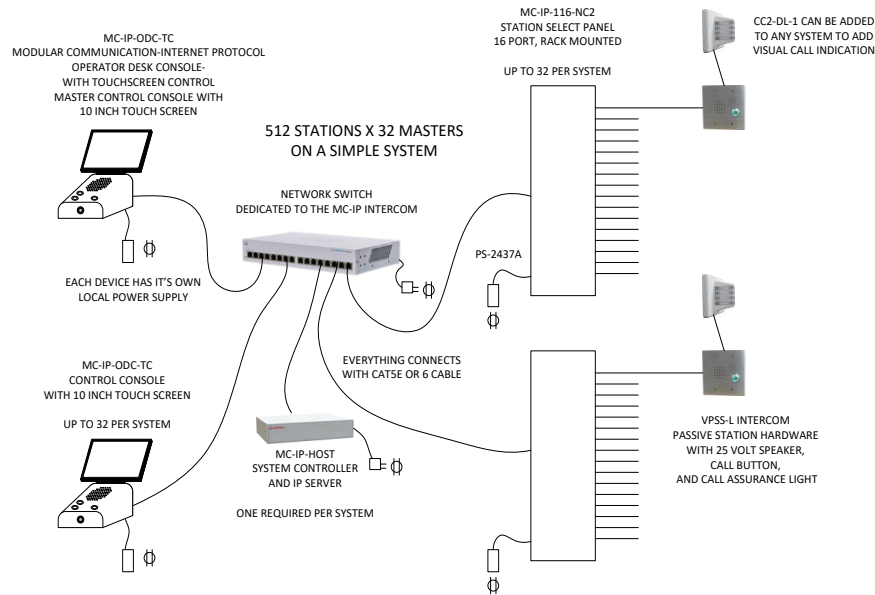

**WHEN MULTIPLE SYSTEMS NEED TO BE TIED TOGETHER,  
THE MC-IP-SERVER PROVIDES CALL ROUTING  
BETWEEN INTERCOM SYSTEMS**

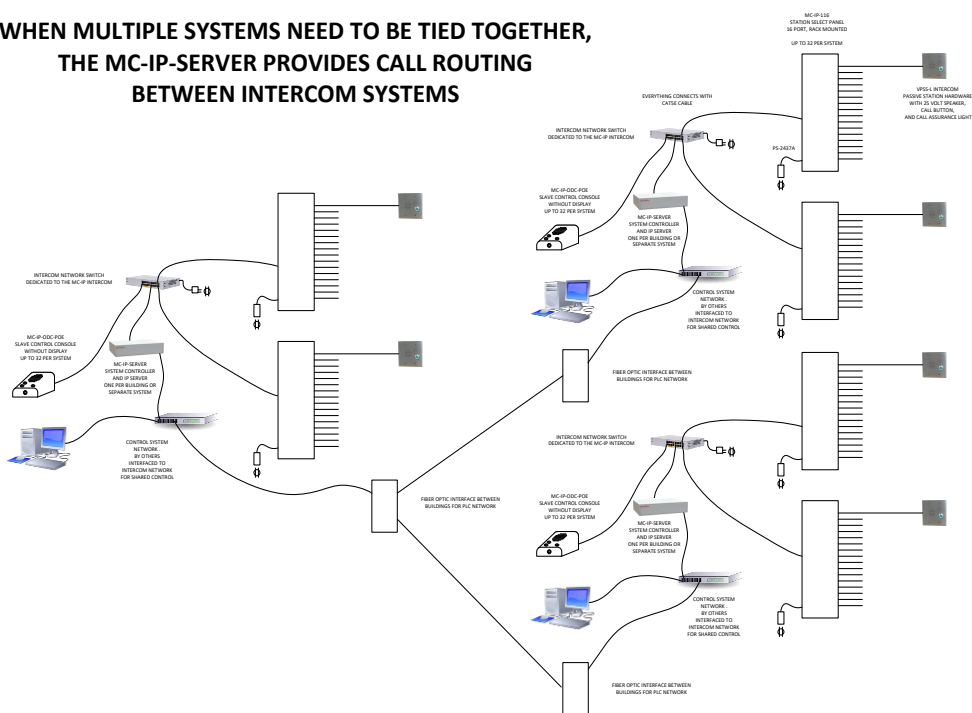

## System Components

MC-IP Components are microprocessor-based units containing their own microcontroller, memory and control logic. **During installation, Static protection such as static bracelets MUST be used at all times when any of the products are opened and vulnerable to electrostatic discharge.**

Two versions of the MC-IP-ODC are made available.

**MC-IP-ODC-TS** is a self-contained Internet Protocol Master audio console with **built in Touch Screen** for system control.

**MC-IP-ODC-POE** is a self-contained Internet Protocol audio console with POE for use in conjunction with touch screen control systems.



The console includes a powder coated metal base with a stainless-steel Faceplate, hidden condenser Microphone, a 3" Speaker, and 3 Vandal Resistant Push Button Switches specifically designed for the Corrections industry. Inside each console are all of the electronics for connection to the network and control of local audio plus remote gain up/down buttons to allow the operator to listen closely to what is said on the remote Station. The Faceplate is Laser Engraved to prevent wear and destruction of labeling. The 3 buttons are "Talk" (Push To Talk), "Listen" (Remote Up), and "Listen" (Remote Down). Remote Listen Level "UP", and Remote Listen Level "DOWN", not a Volume Control, Sets the microphone sensitivity at the Remote Station. The console microphone is mechanically shock resistant mounted on the front of the unit. Frequency selective circuitry shapes the omni-directional microphone for high voice band sensitivity. Tech Works Automatic Level Control makes every voice sound the same and every word as articulate as possible. The integral 3" loudspeaker is moisture resistant and includes vandal resistant metal barriers to protect it from abuse.

**MC-IP-116** is an audio Intercom Station Control Module that communicates over Internet Protocol and includes all audio amplification, control and support for up to 16 remote intercom Stations. Intended for use in facilities such as Correctional Institutions, Security Applications, and Industrial Applications, the MC-IP-116 has 20 watts of built in power output to industry standard 25-volt speaker Stations or paging Speakers. The MC-IP-116 provides high quality audio communication with complete flexible control. The unit has connections for 16 remote intercom Stations, with Speakers, Call-in Switches, and Call Confirmation Lights. A Tech Works PA-Buss connector allows the addition of our 40-Watt paging amplifier where more power is required for large areas such as Day Rooms, Exercise Yards, and Playgrounds. For convenience, all the MC-IP-116 terminations are connectorized. Remote Stations connect via 4 pin 0.1" (2.54 mm) Spring Cage Barrier Strips.





**MC-IP-116-NC2** has 16 RJ45 connectors, one for each remote station. All NC2 devices communicate over standard CAT cable and provide 2 lights, 2 Call Buttons and 1 Voice Path per station connector.

Connection for Power, is a barrel connector or Screw Terminal. Paging Amplifier uses a RJ-45 Connector addition is as easy as plugging in our PA-Buss Cat 6 cable. Associated with each Station is a Status Indicator. The Station Indicators shows the Technician pending calls and which relay or relays are active. When an Indicator is Off there is no activity with that Station. When an Indicator is On Flashing a call is waiting to be answered, and On Steady means that Station is selected for Communication.



**MC-IP-MSI-11** is a Modular Communication over Internet Protocol, Microphone, Speaker, audio Interface designed to take a variety of audio communication products and let them talk to each other over the Tech Works MC-IP Network. The MC-IP-MSI-11 consists of four functional modules; The local Microphone/Line Input; a 25 Volt Speaker Output, the CI-BUSS Interface, and an Ethernet port for MC-IP network connection.



**MC-IP-HOST** is an Internet Protocol Control Module that does several functions including monitor what devices are connected to the network, who wants to talk to whom, who is talking to who, as well as programmed properties and functional programming of each system device. If a device fails or is removed from the system, the MC-IP-HOST puts that device out of service until a new device with the same credential is installed. When a new device appears the MC-IP-HOST automatically transfers all stored settings to the new device to assure that it functions just like the unit that was replaced. This makes field maintenance or repair a simple “swap of the box” for service. The MC-IP-HOST uses a standard SD card to store system programming and configurations. This information can be copied and stored for backup and security. If a MC-IP-HOST is being replaced, the SD card can be moved to the new MC-IP-HOST without the need to be reprogrammed.

The system handles Call Routing, and Busy signaling. When a Connection is established, the Operator is in full control of the Conversation.



**MC-IP-SERVER** is an Internet Protocol Control Module like the MC-IP-HOST but it does a lot more. Where the HOST can support 2 “ports” for external touch screen computers from control systems, each SERVER can support 32 ports and 32 SERVERS can be interconnected. The SERVER also acts as a router for communication between multiple MC-IP systems. The MC-IP-SERVER has 2 TCP/IP connectors; one for the local Host functions connected to the local network and second to connect a local system to other systems on a second network. This allows 32 systems to seamlessly connect to each other for a total of  $32 \times 32 = 1024$  Operators and  $32 \times 32 \times 16 = 16,384$  remote stations



**MC-IP-SW-16-RM** and **MC-IP-SW-16-POE-RM** are Gigabit Ethernet LAN switches with 16 LAN ports. Each MC-IP system requires an ethernet network switch to connect all of the MC-IP system components. The MC-IP is a dedicated network used only for Tech Works MC-IP system communication. The MC-IP is connected to other IP products and networks by router WAN ports to insure the best possible performance of all audio communication. All of the MC-IP Switches are rack mountable



**VPSS-L** is a two-gang correctional/industrial grade Passive Intercom Speaker Station designed for the most demanding environments. The speaker/microphone is moisture resistant, includes a 25 Volt matching transformer, and employs three steel barriers to protect it from tampering and vandalism. The integral "Call-In" switch is hermetically sealed and utilizes a limited travel actuator to protect from excessive force or moisture. An ultra-bright LED call confirmation light built into the button lets the caller know that their call has been placed. The 12-gauge stainless steel faceplate and tamperproof mounting hardware makes the VPSS-L almost indestructible.



**MC-NC2-VPSS-2G** is a two gang Vandal Resistant Passive Intercom Speaker Station designed for very demanding environments. The Speaker Station employs a computer designed speaker/microphone and acoustic coupler that delivers superior speech intelligibility. The speaker/microphone is moisture resistant and employs three steel barriers to protect it from tampering and vandalism. The integral "Call-In" switch is hermetically sealed and utilizes a limited travel actuator to protect from excessive force or moisture. The MC-NC2-VPSS-2G has a built-in call canceled button with integral call confirmation light. The **MC-NC2-VPSS-2G-RC** is also available for Remote Cancel applications



**MC-NC2-DL-22-RW** is a stylish, exceptionally bright Nurse Call 2 Color Dome Light. The **MC-NC2-DL-22** are equipped with RJ45 CAT5 connector for installation convenience. A single Dome Light can monitor and display 2 system station ports for discrete audio to 2 patient stations in a single room. The **MC-NC2-DL-22** supports Normal Calls and Emergency Calls. When no calls are originating from a room, the Dome Light is Off. When a "Normal Call" is placed, the Dome Light illuminates the White Light. When an "Emergency Call" is pending, the Red Dome Light flashes. Calls can be cancelled from the Station where the Call was originated or by being answered by the operator. Call Cancellation is completely programable. The Dome Light will only turn off when calls are cancelled at all Call Stations



**MC-NC2-DL-44** is a stylish, exceptionally bright Nurse Call 4 Color Dome Light. The **MC-NC2-DL-44** supports Normal Calls and Emergency Calls. When no calls are originating from a room, the Dome Light is Off. The 4 colors Red, Yellow, Green, and White are associated with separate station locations in a single room or space. Each color indicates a call from a separate station. The Dome Light will only turn off when calls are cancelled at Call Stations.



**MC-NC2-VP-SAS** is a call for HELP Station with a Vandal Resistant Push button with concentric Call Assurance Light built in to the button and mounted on a rugged stainless-steel plate. A convenient Push for Help button is provided for activating the Emergency Call directly at the station. Staff is provided with a distinctive "CANCEL" button to reset the station.



**VPBL** is a Vandal Resistant Push button with concentric Call Assurance Light built in to the button and mounted on a rugged stainless-steel plate. This station can be used as either a Call station or a local Remote Cancel Station.



**VPKS-1** Vandal Resistant Key Switch can be used as either a local Remote Cancel Station or a Staff Assist Activation Station. The Key can be used to activate the Staff Assist stations only when staff is entering that area to prevent false alarms.



**PRO SGM** is a complete Shot Gun Microphone system, including the microphone, a Swivel mounting bracket, an 18 inch cord, and a wall mounting plate with XLR jack and wiring pigtail. Everything you need for a professional, pin point, wall mounted microphone is included. The Swivel mounting system allows full articulation of the microphone for precise aiming. The 1-gang wall plate provides both the microphone mounting and the XLR jack for wiring. A 6” wiring pigtail makes terminating the microphone wire a simple splice. The entire system mounts to a standard 1-gang electrical box.



**HM-1** Hidden Microphone is designed and constructed for use in Interview, Interrogation, and observation applications where a highly sensitive voice microphone can pick up the conversation while not being seen. The microphone is mechanically shock resistant mounted on a nylon deco wall plate. An electronic balancing circuit shapes the omni-directional microphone for high voice band sensitivity while adapting it for low impedance connection over long wire lengths with minimal noise.



**CRS-WM** is a Wall Mount Clean Room Speaker complete with wall mounting steel enclosure. This unit is designed to be cleaned and has a water proof 25V speaker and gaskets to seal it from emitting dust or letting water into the speaker enclosure.



**CRS-RC** is a Round Ceiling mount Clean Room Speaker which includes a backbox and all required mounting hardware. This unit is designed to be cleaned and has a water proof 25V speaker and gaskets to seal it from emitting dust or letting water into the speaker enclosure.



**CAT6-\*** (“\*” specify Length) is an EIA 568B standard computer network Patch Cable designed to connect our Tech Works products together. These units are designed for the systems integrator to make installation Plug and Play.



**PS-2437B** is a regulated computer grade power supply capable of providing 3.75 Amps of power at 24-Volts DC to any of our products. A 6-foot removable power cord with a North American standard Edison connector is included along with a metal mounting bracket to allow the unit to be screwed to the wall or under a counter.



**PC-\*** (“\*” specify Length) is a Power Patch Cable designed to connect our Tech Works Collaborative Intercom (CI-Buss) and PA-Buss products together. These units are designed for the systems integrator to make installation Plug and Play. **18-gauge** power cord is made with 5.5 mm barrel connectors on each end for connecting 24 VDC power from one unit to the next.

***Static protection such as static bracelets MUST be used at all times when any of the products are opened and vulnerable to electrostatic discharge.***

## System Wiring and Connections

### Network Configuration and Setup

The Tech Works MC-IP is utilizing a dedicated standard Ethernet network for its inner communications as well as external control through API commands. Standard Ethernet cabling such as Cat 5e/6 can be used. Each node of the MC-IP product line sends TCP and UDP messages using a 100Mbps network link. All switches/routers used in the network should be no less than 100Mbps. It is recommended that 1,000Mbps (1Gbps) routers/switches be used.

When designing a network for the MC-IP system, measures should be taken as to make sure that network bottlenecks are avoided. Bottlenecks can happen when there are many calls happening simultaneously over the same network link. Though switches/routers can help to create the most efficient path, poor network design can have an effect.

For example:

If all the ODC's are on Switch 1 and all the 116's are on Switch 2, any call from an ODC to a 116 must cross the Switch 1 to Switch 2 link. If there are many simultaneous calls, this could create a network bottleneck and could cause problems in the MC-IP system. A better design would be to put ODC's and 116's often used together on the same switch. If multiple switches are required, then planning should be done to put the most amount of traffic for ODC-X to 116-X on the same switch. This would limit the number of calls that need to cross the Switch 1 to Switch 2 link. When possible, it is recommended that all nodes of the MC-IP system be on the same switch. If multiple switches are required, the link between switches should always be at 1GBps or faster speeds.

If external control is to be used, it is highly recommended that a router be used to isolate the MC-IP network from any other network. Only the necessary ports and traffic should be allowed to pass through the router as needed. If a router is used, it should NOT be configured as a DHCP server. The LAN IP settings of the router should be the following:

IP: 172.30.100.1  
MASK: 255:255:255:0

Each node on the MC-IP network has a static IP address. Products such as the MC-ODC and MC-116 have a 16-position rotary switch and a jumper to determine its Network Identity including its IP address. These IP addresses are preset and cannot be changed

The following are the IP Addresses assigned by the HOST:

MC-IP-HOST and MC-IP-SERVER: 172.30.100.2  
MC-IP-ODC #0-15: 172.30.100.20 – 35  
MC-IP-ODC #16-31: 172.30.100.36 – 51  
Reserved for future: 172.30.100.52-83  
MC-IP-116 #0-15: 172.30.100.84 – 99  
MC-IP-116 #16-31: 172.30.100.100 – 115  
MC-IP-MSI-11: 172.30.100.116-179

### Connecting a laptop to the MC-IP Network

To talk to the MC-IP network for programming, it is best to plug your laptop directly into the MC-IP switch and set your laptop "Network Properties" to "Manual".

Then configure as follows:

Select IPv4  
IP address: 172.30.100.75  
Subnet: 255.255.255.0  
Gateway: 172.30.100.2  
If required Subnet Prefix Length: 24

## MC-IP-HOST Connections



Because the MC-IP-HOST assigns IP addresses and loads the configuration to all other system devices, the HOST should always be connected first. All other components can be connected and disconnected with the system live but the HOST should always be connected and powered on before the network switch is even powered on.

Power is 24 Volts DC and is connected using Tech Works standard 5mm barrel connector

The Network connection is a standard CAT6, 568B wiring jack and should be connected directly to the Tech Works Network Switch.

When the unit is powered on a green indicator between the 2 power connectors will light up indicating that the unit has power.

If the running correctly the “Processor Running” light will flash very fast.

There are 2 lights on the TCP/IP Connector that when properly connected to a working ethernet switch or router will flash very fast to indicate that there is a good connection.

All other adjustments and configuration with the MC-IP-HOST are done through software.

### SD Card

The MC-IP HOST includes an SD Card for storage of the system configuration. The SD card can only be accessed by removing the lid of the MC-IP-HOST. The SD Card is where the system configuration for this HOST is stored. The reason for this is if there is ever a HOST failure, the SD Card can be removed and installed in a new HOST and the new HOST will read the SD Card on boot strap and will set the system up exactly as it was before.

Using the Tech Works MC-IP Configurator Program, create the system configuration you want to use and save it. You must use the MC Configuration software to load the Configuration into the HOST SD Card. You can use the “Uploader” function built into the MC Configuration software if the computer running the Configurator software is connected to the MC-IP-HOST network. The file is copied to the SD Card installed in a HOST and the configuration will be read on boot strap (startup).

Be sure to save the file under the project and HOST name. Your file will be saved on your computer under that name followed by “.mccfg”. Simply copy this file to the Uploader and load it to a HOST and it will send it to a formatted SD card. You can then remove the SD Card and archive it or swap the one in MC-IP-HOST in the field. In this way, changes can be made by sending a technician out to the field without a computer.

The SD Card must be formatted to File System FAT32 for proper operation.

Always keep the MC-IP-ODC on the same network switch as the MC-IP-116s that it needs to communicate with for best performance.

### Systems with API control interface from an external Touch Screen control system

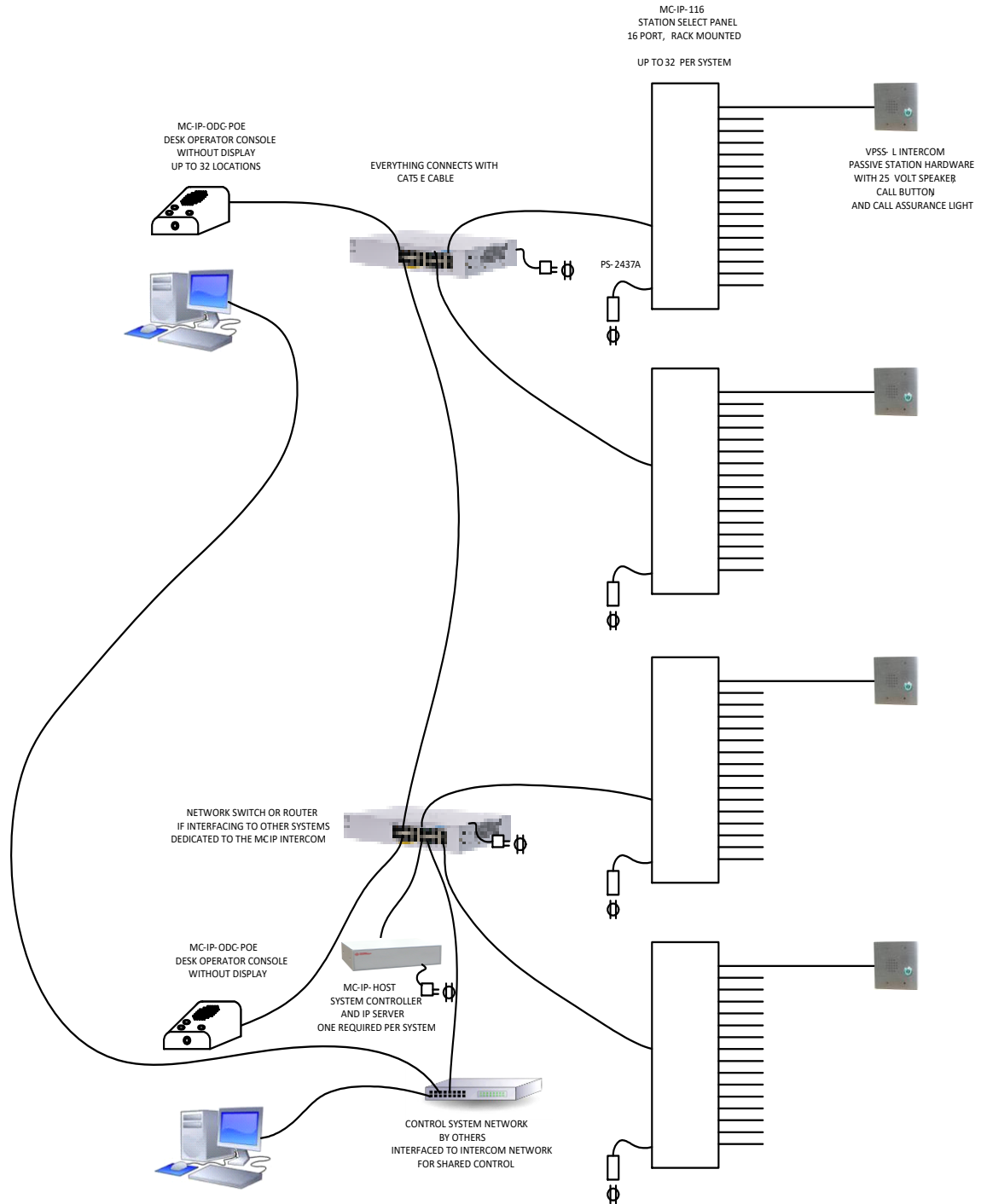

## MC-IP-SERVER Connections:



The MC-IP-SERVER acts as the local HOST and assigns IP addresses and loads the configuration to all other system devices, the SERVER should always be connected first. All other components can be connected and disconnected with the system live but the SERVER should always be connected and powered on before the network switch is even powered on.

Power is 24 Volts DC and is connected using Tech Works standard 5mm barrel connector

The Network connections are both standard CAT6, 568B wiring jacks. The MC-IP-HOST connector should be connected directly to the local Tech Works Network Switch. The “LAN/WAN” Ethernet Connector is for connection to the Wide Area Network or a system with more than 2 touch screen control stations. This does not apply to the MC-IP-ODC-TS which has its own touch screen and does not require a SERVER for 32 Operator stations.

When the unit is powered on a green indicator between the 2 power connectors will light up indicating that the unit has power.

There are 2 lights on the TCP/IP Connector that when properly connected to a working ethernet switch or router will flash very fast to indicate that there is a good connection.

All other adjustments and configuration with the MC-IP-HOST are done through software.

### SD Card

The MC-IP SERVER includes an SD Card for storage of the system configuration. The SD card can only be accessed by removing the lid of the MC-IP-SERVER. The SD Card is where the system configuration for this SERVER is stored. The reason for this is if there is ever a SERVER failure, the SD Card can be removed and installed in a new SERVER and the new SERVER will read the SD Card on boot strap and will set the system up exactly as it was before.

Using the Tech Works MC-IP Configurator Program, create the system configuration you want to use and save it. You must use the MC Configuration software to load the Configuration into the Server SD Card. You can use the “Uploader” function built into the MC Configuration software if the computer running the Configurator software is connected to the MC-IP-SERVER network. The file is copied to the SD Card installed in a SERVER and the configuration will be read on boot strap (startup).

Be sure to save the file under the project and SERVER name. Your file will be saved on your computer under that name followed by “.mccfg”. Simply copy this file to the Uploader and load it to a SERVER and it will send it to a formatted SD card. You can then remove the SD Card and archive it or swap the one in MC-IP- SERVER in the field. In this way, changes can be made by sending a technician out to the field without a computer.

The SD Card must be formatted to File System FAT32 for proper operation.

# Expanded systems using SERVERS to interconnect multiple MC-IP systems

## WHEN MULTIPLE SYSTEMS NEED TO BE TIED TOGETHER, THE MC-IP-SERVER PROVIDES CALL ROUTING BETWEEN INTERCOM SYSTEMS

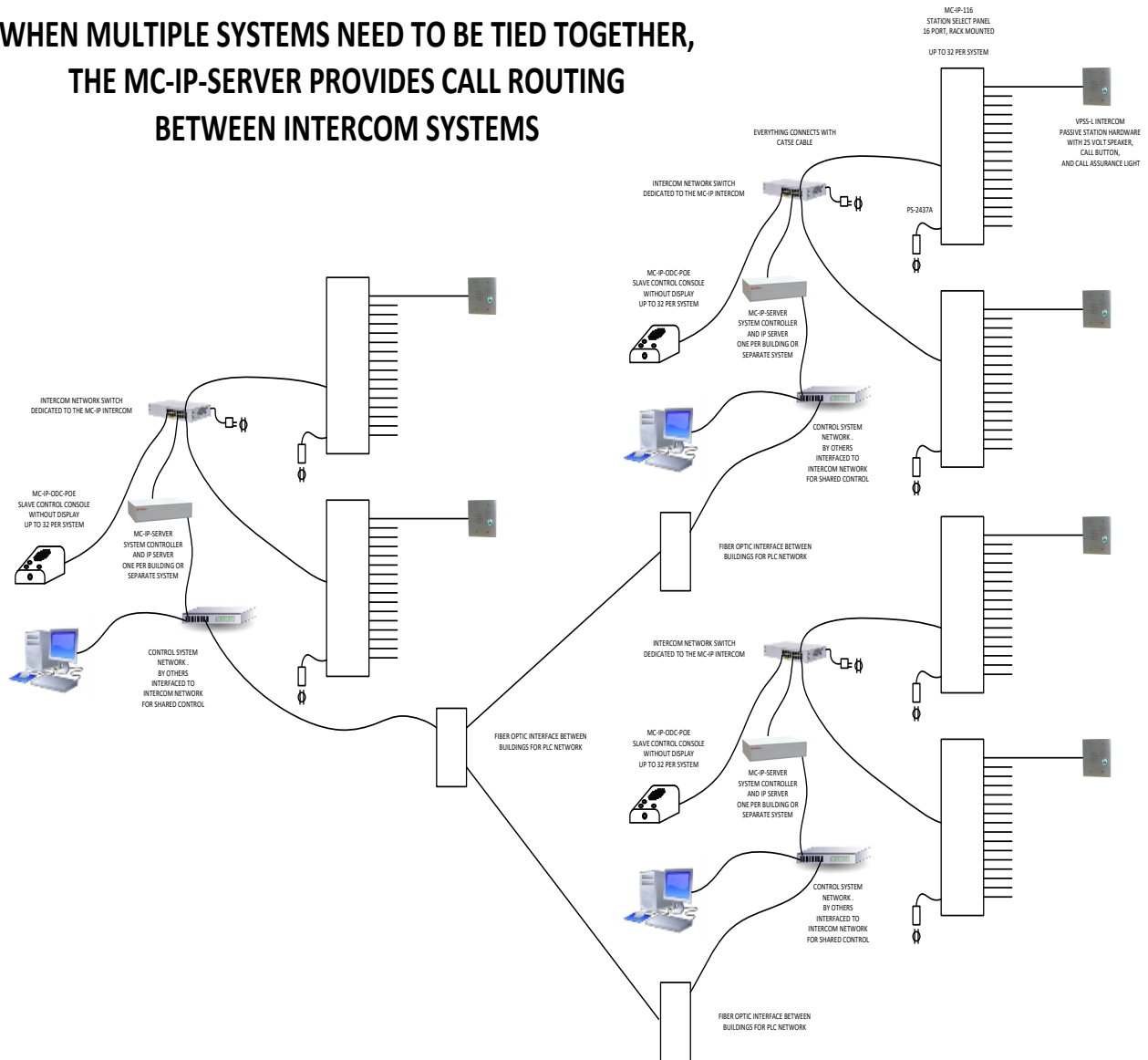

## MC-IP-ODC Connections

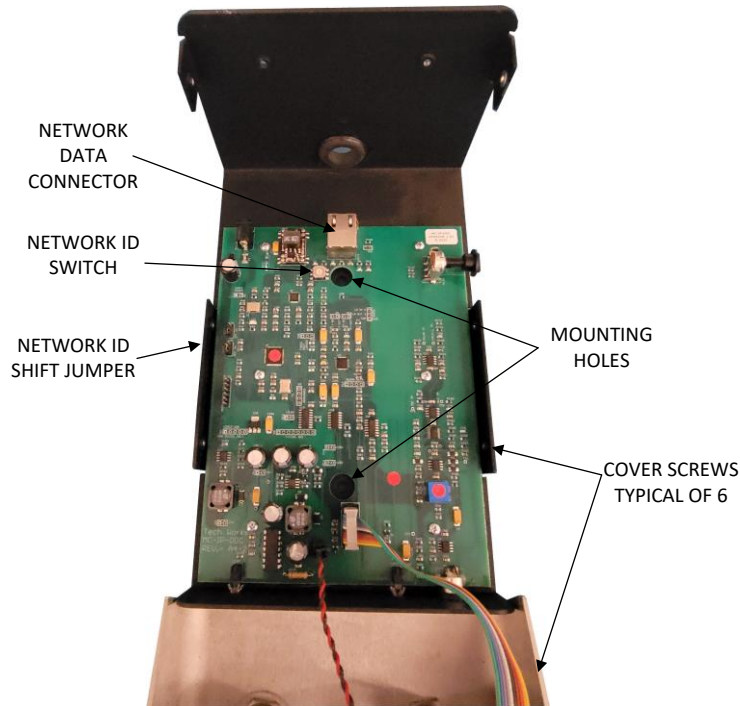

***Static protection such as static bracelets MUST be used at all times when any of the products are opened and vulnerable to electrostatic discharge.***

All Of the connections for the MC-IP-ODC are inside the console for security purposes. By removing the 6 cover screws on the sides of the ODC the top will easily tip forward. Run the CAT6 cable connector through the grommeted opening at the back and plug it into the ODC.

There are 2 mounting holes provided to secure the console to the counter top if desired. It is always best practice to install the counter mounting screw without power applied in case you drop a screw or a tool.

The only user settings inside the ODC are the network ID rotary switch and the address shift jumper P4 labeled "OPT !". The rotary switch selects the address 0-15 and by moving the OPT 1 switch to the "ON" position the rotary switch sets the ID to 16-31.

Replace the cover.

### **Operation:**

Apply power and make sure that the power light on the front of the console comes on.

Whenever an ODC microphone is active the Push To Talk light will light and whenever the speaker is active the Reach lights will light up.

Console conversations are established through the control touchscreen. Once a call is connected the Reach lights should come on to indicate that the speaker is active and you should be hearing the distant remote station. To increase the Listening sensitivity, push the "Reach Up" button repeatedly will make the remote louder. If it is too loud, pressing the "Reach Down" button repeatedly will turn the remote down. Remote Listen Level "UP", and Remote Listen Level "DOWN", is not a Volume Control, it sets the microphone sensitivity at the Remote Station.

Depending on the software configuration of an ODC it can be called by another ODC. When one ODC calls another, the calling ODC will control the direction of the conversation with its Push To Talk button. The Called ODC will have its Push To Talk (PTT) light on to tell the operator that they are being listened to and when the caller pushes their PTT button the called station PTT light will go off and their Reach light will go on.

## MC-IP-116 Connections



All system components employ RJ45 connectors for a couple of purposes

1. For connection of Tech Works PA-Buss components such as the PA-402
2. For connection of components to the IP Network

Either application assumes standard off the shelf CAT6 cables wired to EIA/TIA 568B

Power connections are on both the Euro Style Screw Block and the 2.00mm ID (0.079"), 5.50mm OD (0.217") Barrel connector for 24 VDC.

Screw terminal power connections are always:

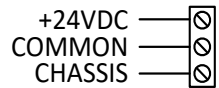

External Paging Amplifier connections are always:

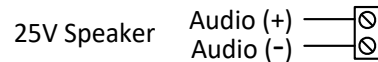

Station field wiring is a 4-conductor compression clamp connector with 0.1 inch spacing and will connect to 18-24 AWG wire. Wires must be stripped of insulation approximately 1/4 inch from the end before being inserted in the connector. A slot above each connection allows the insertion of a 2.0 mm tech blade screw driver to release the clamp so that you can remove the wire if necessary.



Remote Station connections are:

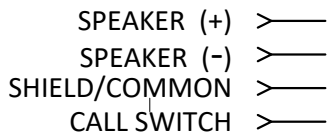

Industry standard intercom wire is

similar to shown above. The speaker pair is normally twisted and shielded. The Call In wire is an extra conductor outside of the shield. The Shield is connected to ground or common only at the amplifier or control module, in this case the MC-IP-116.



Connect the station call button to the Shield and the call in wire (White) Do not connect the shield to the electrical box or conduit ground.

Connect the Twisted audio pair (Red/ Black) to the 25 Volt audio transformer on the speaker. Typically, the 25 Volt tap is either 1/2 or 1 Watt.

## External Paging Amplifier

For paging a group of speakers, you must have enough audio power available to drive all of the speakers in a page group. The MC-IP-116 has a built in 20 watts used for both intercom “Talk” functions and Paging. This means that there is 1.25 Watts per port built in. This is more than enough for standard cells and door stations. If you are trying to page a string of speakers in a day room or exercise yard, you could have 20 watts of speakers hooked to one port.

Add up the watts of load attached to each port to determine if 20 watts is enough. If not, then you need to add an external Paging Amp like the Tech Works PA-402 which delivers 40 Watts.

## Connecting an External Paging Amplifier

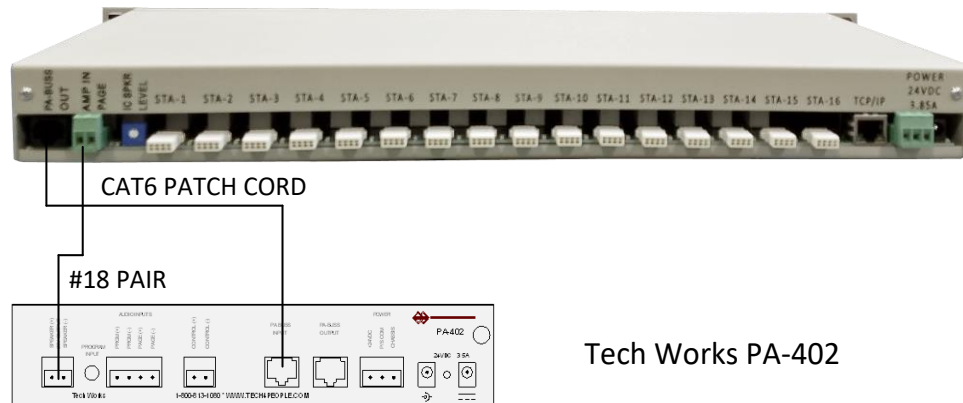

Tech Works PA-402

The External Paging Amplifier is connected to the MC-IP-116 by a CAT6 patch cable from the PA-Buss Output of the MC-IP-116 and into the PA-Buss Input on the PA-402 Amplifier. The PA-Buss provides both the line level audio connection and the Activate signals to tell the PA-402 when the MC-IP-116 is Talking. The 25 Volt 40 Watt Output screw terminals of the PA-402 is then connected to the External Page Amp Input screw terminals on the MC-IP-116 using an 18 gauge twisted pair wire (Speaker (+) to Speaker (+) and Speaker (-) to Speaker(-)).

In programming you will see how to set up page zones. Before you start programming the zone you need to tell the system that it is to use an external Page Amp by checking the box in the station configuration screen for the MC-IP-116.

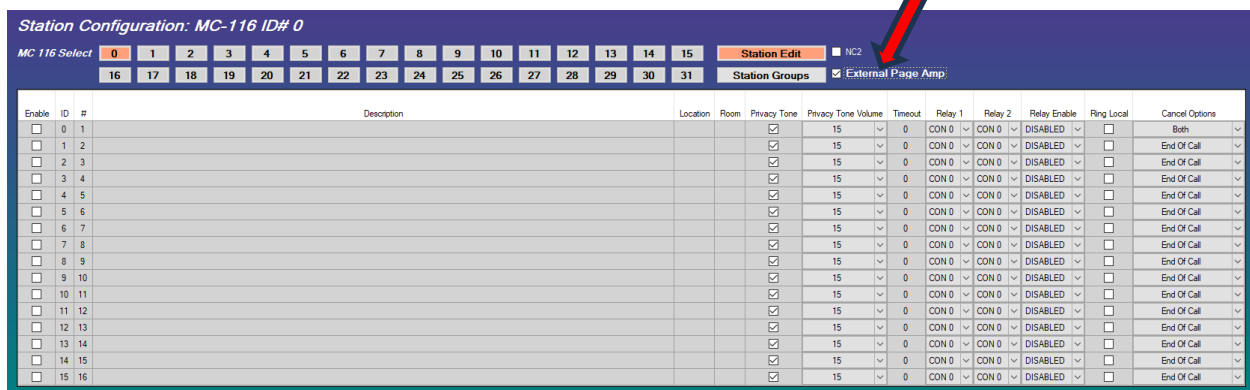

The check box in programming is set for each 116 to tell it to either use the built in 20-watt amplifier or an external amplifier connected to the 116. If the External Paging Amplifier is set “On” (Checked), then each time the 116 is told to page it will automatically activate the built-in page relay and connect the External Amplifier screw terminal inputs to the Station select bus. If this feature is set to “Off” (Unchecked) the built-in page relay will not activate and the internal 20-Watt amplifier will be used for paging program amplification.

## MC-IP-116-NC2 Connections



The MC-IP-116-NC2 has 16 RJ45 connectors, one for each remote station. All NC2 devices communicate over standard CAT cable and provide 2 lights, 2 Call Buttons and 1 Voice Path per station connector. Dome lights and stations have a CAT In and a CAT Out connector so that the installer can run the CAT cable from station to station and select the call type and signal level via jumpers on the station. The system does not care what order stations are wired in.

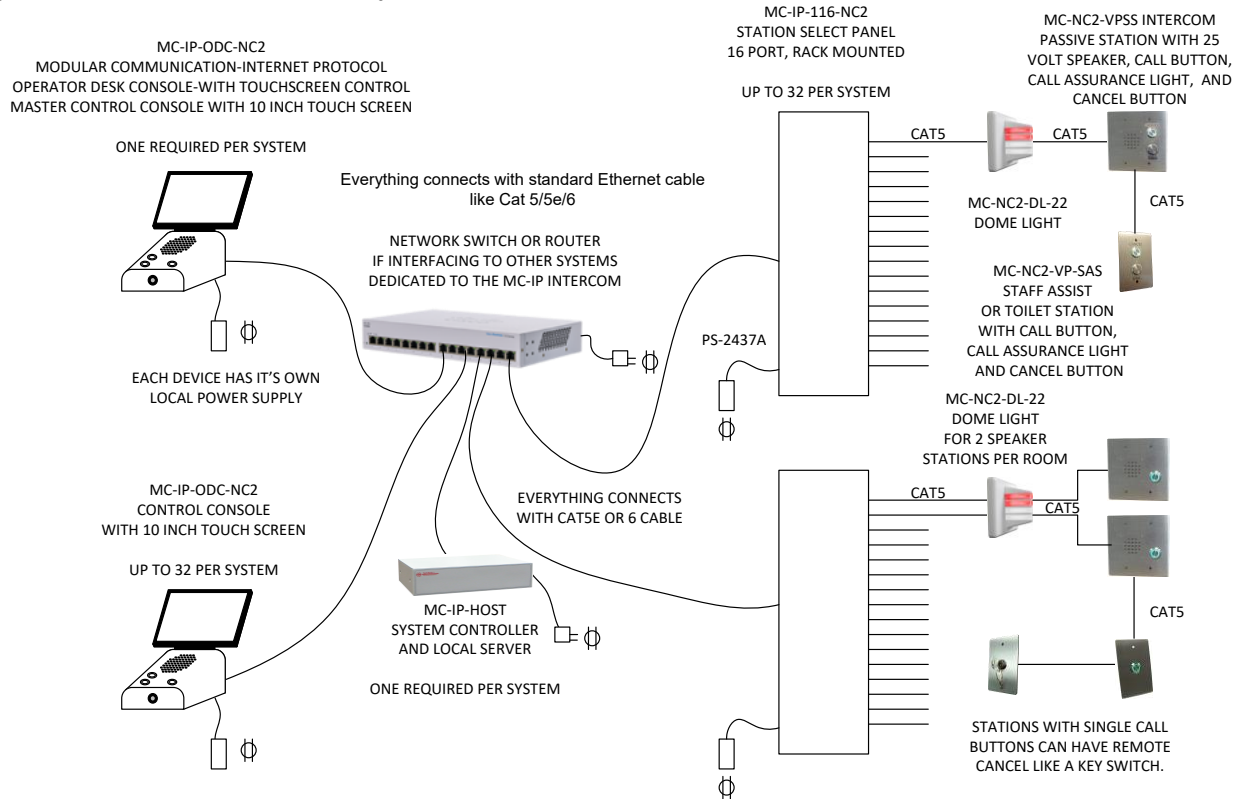

## Station Connector Wiring

### MC-NC2 STATION CONNECTOR PIN OUTS

← 1	IND-PWR_(+)
← 2	/NC2_CALL-IN-1
← 3	/NC2_LITE-OUT-1
← 4	+_SPEAKER
← 5	-_SPEAKER
← 6	/NC2_LITE-OUT-2
← 7	/NC2_CALL-IN-2
← 8	POWER_(-) COMMON

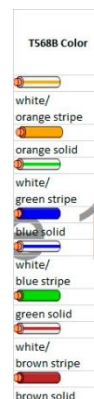

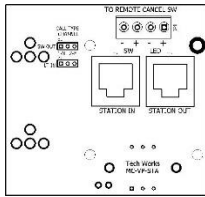

**MC-NC2-VPSS-2G** is a two gang Vandal Resistant Passive Intercom Speaker Station with an ultra-bright LED call confirmation lighted call button. Jumpers on the back of the station allow the installer to select Normal or Emergency level calls from this station and whether to light the top of bottom light of the Dome Light. Stations are available in both local cancel and remote cancel



**MC-NC2-VPSS-2G-RC** The “RC” stands for Remote Cancel meaning that the call can be canceled from the administrative console or a remote contact like a key switch or push button. Local Remote Cancel switch (with or without light) Connects to screw terminals on the top Rear of the station. The Remote Cancel can be any contact closure such as a button or a key switch



The Tech Works **MC-NC2-VP-SAS** and **VPBL** are call for HELP Station with a Vandal Resistant Push button with concentric Call Assurance Light built in to the button and mounted on a rugged stainless-steel plate. A convenient Push for Help button is provided for activating the Emergency Call directly at the station. Staff is provided with a distinctive "CANCEL" button to reset the station or, Remote Cancel can be any contact closure such as a button or a key switch. Local Remote Cancel switch (with or without light) Connects to screw terminals on the top Rear of the station.



Remote Cancel options include the Tech Works VPKS-1, a Vandal Resistant Key Switch station normally used as a remote reset or “Cancel” station on our NC-Series Nurse Call products and is specifically designed for the Healthcare and Security industry. With its pre-wired connections, it is easy to install and requires no maintenance. It is perfect for those locations where call cancel without enter a prison cell is required but may be subject to abuse or vandalism.

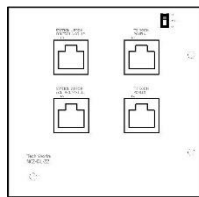

**MC-NC2-DL-22** is a 2 color Dome Light where each color indicates a call from a separate station sharing a single voice path to that room. A “Normal Call” illuminates the White Light and an “Emergency Call” will light the Red Light

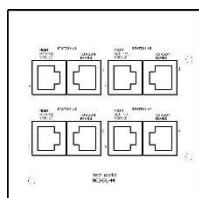

**MC-NC2-DL-44** is a 4 color Dome Light where each color indicates a call from a separate station with individual voice paths. The 4 colors Red, Yellow, Green, and White are associated with separate station locations in a single room or space.

## MC-IP-MSI-11 Connections



### Speaker Output:

Two Position Euro-Style Barrier

### Strip:

Speaker (+)

Speaker (-)

*25-Volts, 10-Watts Maximum*

### Microphone Input:

Four Position Euro-Style Barrier

### Strip:

Universal Microphone/Line Input (+)

Universal Microphone/Line Input (-)

Shield/Switch Common

Talk Switch (N.O.)

*Configured for a Microphone Level Input:*

*2000 Ohms Balanced*

*-75dBm or -60dBm (Selectable) minimum*

*input (Balanced) for full rated output*

*Selectable Equalization - 3 settings*

*optimized for voice communication*

*Selectable Phantom Power (22 Volts, Short Circuit Protected)*

### Call Switch:

Two Position Euro-Style Barrier

### Strip:

Call Switch (+), (N.O.)

Call Switch (-)

RJ-45, CI-BUSS, "Master" Connector

RJ-45, CI-BUSS, "Slave" Connector

Microphone ON (someone is listening to you)

### Remote Indicator Output:

Three Position Euro-Style Barrier

### Strip:

Current Limited 24VDC (+)

Common 24VDC (-)

Mic On – pull to common control

Mic On local Indicator

### Network I.D. – Rotary Hex Switch

Sets local unit IP address so that the MC-IP Network Host will recognize it. See jumper settings below for more details. When using the MC-IP-MSI-11 with MC-IP-116, the MSI defaults to the first 32 points in the configuration program. So if you employ both in a single system, set your first MC-IP-116 to Network ID "2" to avoid conflicts.

Shielded RJ-45 Ethernet Connector to MC-IP Network

### Power Connectors: (Two)

3.5mm Barrel Connectors

**24Volts, 1.5 Amps Maximum, depending on Speaker load**

## What is an MC-IP-MSI 11 used for?

### Procedure and Clean Rooms in Healthcare

Whenever 2 or more Operators want to talk to places like clean rooms the MC-IP-ODC-TS can be connected to select any of up to 64 MC-IP-MSI-11 connected to the network.

Each MC-IP-MSI-11 is assigned to a space like a clean room or operating room and connects to its local Speakers and Microphone. Adjustments are made in each MSI to meet the acoustic needs of that space. The MSI can also support a light to tell the people in the room when their microphone is on and they are being listened to. Foot switches can also be added to place a call to an Operator or to activate the Microphone so that it is only on when they Push (step) TO Talk.

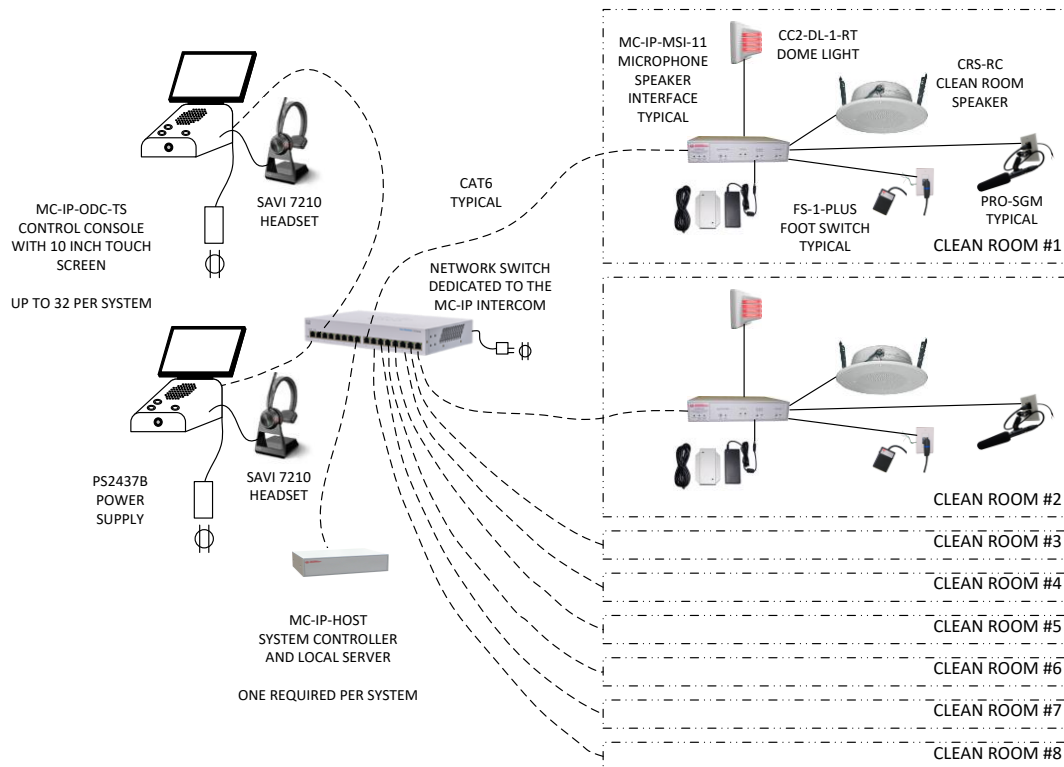

### Observation and Isolation in Detention and Mental Healthcare

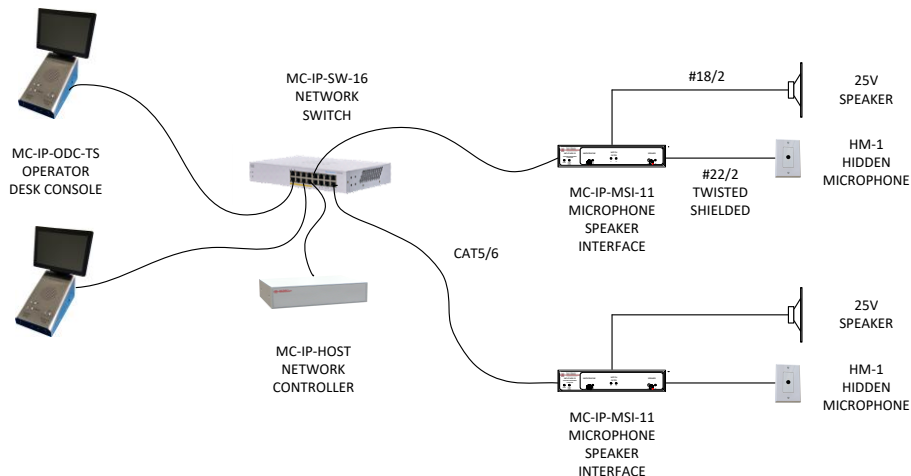

## MC-IP-MSI-11 Internal Jumpers

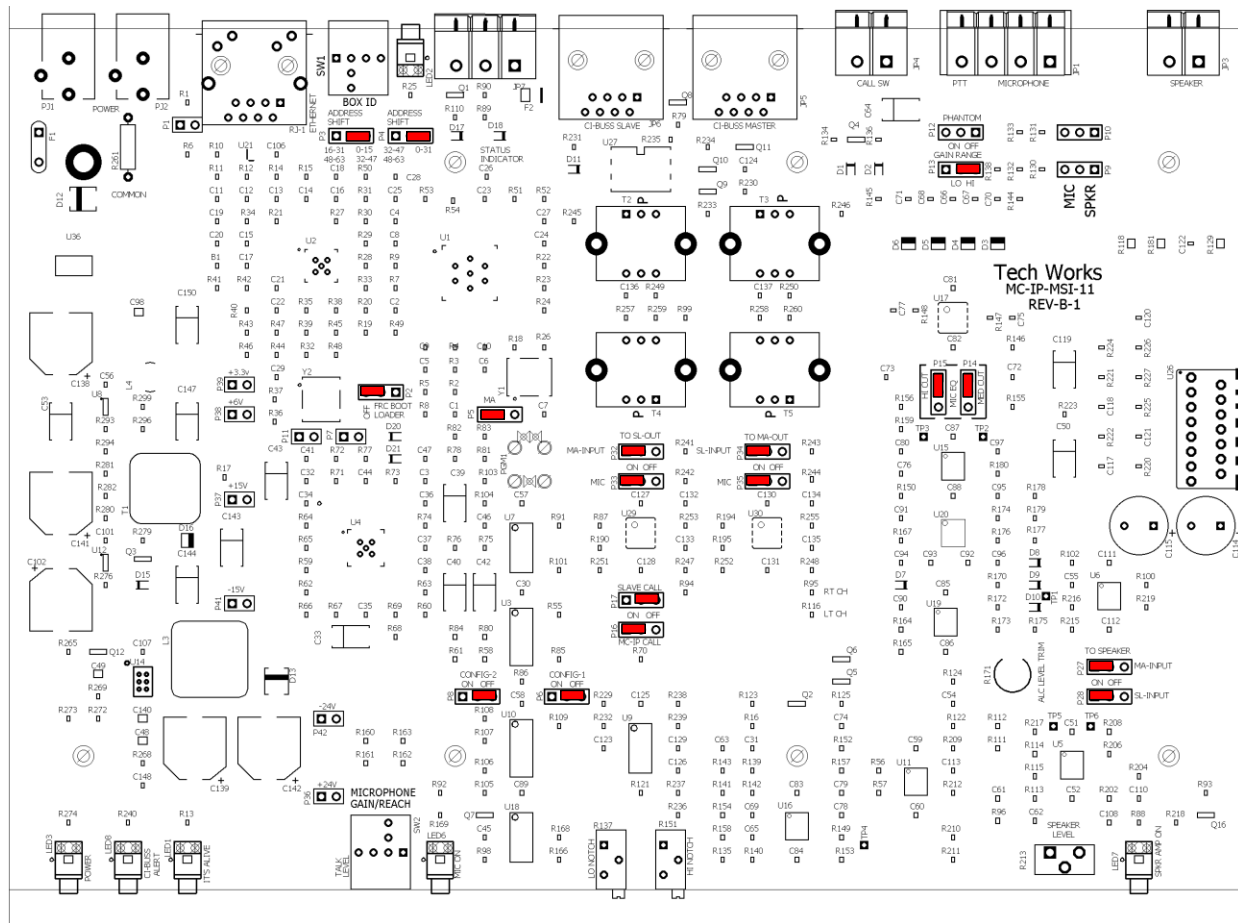

The MC-IP-MSI-11 has several internal jumpers to tailor the operation of the unit to the application. All the jumpers are shown in their “Default” positions.

- P3 Address Shift – Used to set the Station ID range of the rotary switch on the back. When set to the Right the address range is 0-15 which will correspond to IP Address 172.30.100.116 - 172.30.100.131. When set to the Left the address range is 16-31 which will correspond to IP Address 172.30.100.132 - 172.30.100.147
- P4 Option 2 – Address Shift –When set to the Left and P3 to the right the rotary switch address range is 32-47 which will correspond to IP Address 172.30.100.148 - 172.30.100.163 and with P3 set to the left and P4 set to the left the rotary switch address range is 48-63 which will correspond to IP Address 172.30.100.164 - 172.30.100.179
- P2 Force Boot Loader - Only used to restore software in the event of a problem.
- P12 Phantom – 24 VDC Power to a condenser microphone ON/OFF. This jumper is not installed for field setting. Consult the factory for applications.
- P13 Gain Range – Pads the input signal down by 15 dB if it is too loud.
- P14 MID CUT – Takes out the octave around 1K Hz by ~ 10dB which is typically the ringing sound in very hard acoustic environments.

P15 HI CUT – Shapes the Microphone audio frequency response by rolling off the signal at ~ 3dB/Octave above 4K Hz.

Taking out P13, P14, and P15, the input becomes a line level 0dB

CI Source - Determines what audio signals go to the CI-Buss Connectors and are heard by other CI-Buss devices if installed.

P32 MA-INPUT – Do you want the audio from the CI Master Connector to go to the CI-Slave Connector?

P33 MIC – Do you want the audio from this MSI Microphone to go to the CI-Slave Connector?

P34 SL-INPUT – Do you want the audio from the CI Slave Connector to go to the CI-Master Connector?

P35 MIC – Do you want the audio from this MSI Microphone to go to the CI-Slave Connector?

P27 MA-INPUT – Do you want the audio from the CI Master Connector to go to the Speaker?

P28 SL-INPUT – Do you want the audio from the CI Slave Connector to go to the Speaker?

Software Configuration – No Jumpers = Full Bi-Directional Audio, No Privacy Tone

P6 Config-1 On, Push To Talk Switch activates Microphone.

P8 Config-2 On, Privacy Tone ON letting the listener know they are being monitored.

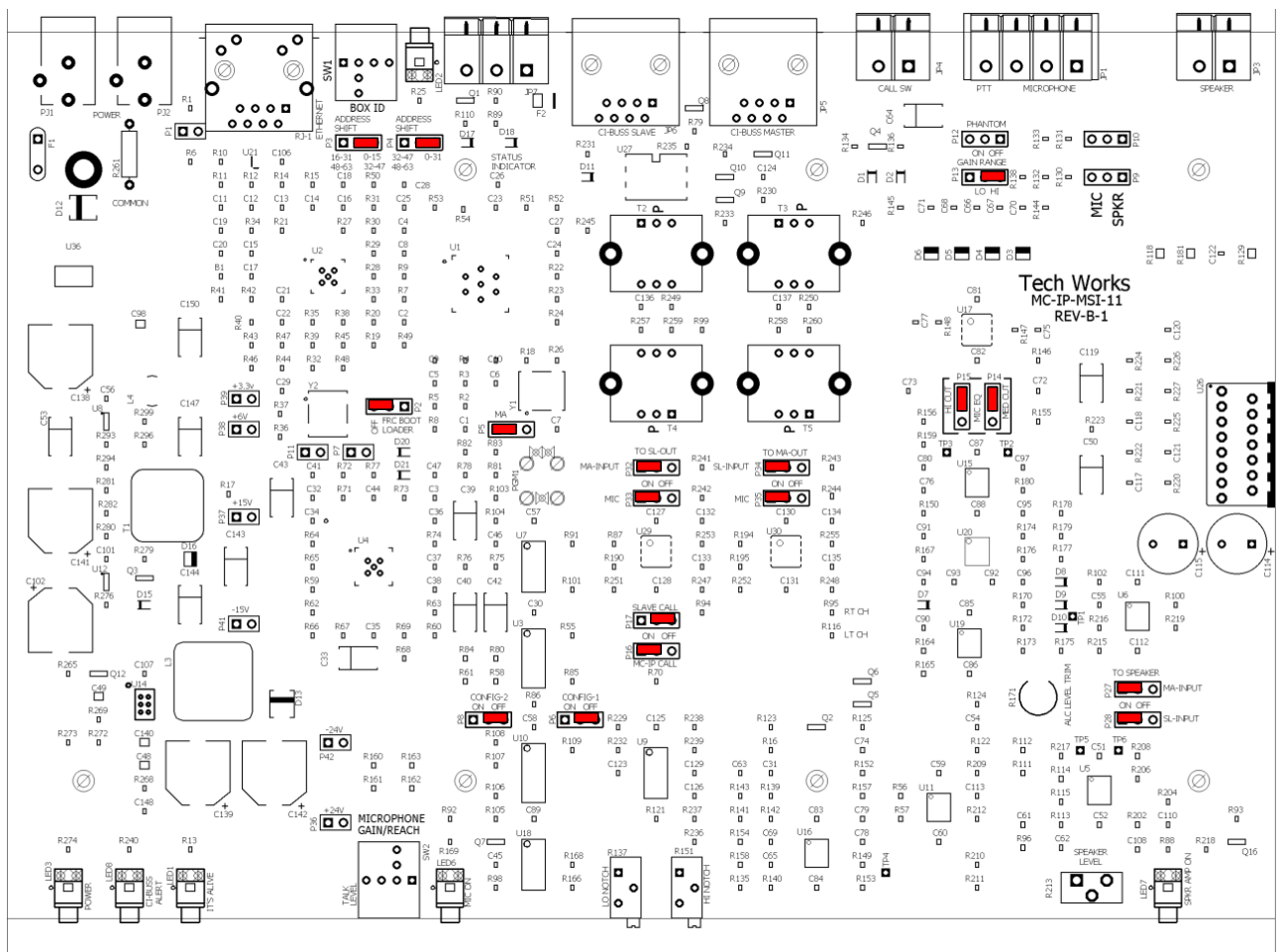

For more information on the CI-Series and the various options of those products visit <https://techworks-usa.com/dealer-ae/data-sheets/#CI>

## MC-IP Features and Programming Options

When any MC-IP-ODC Operator Desk Console selects a Station to have a conversation, either Master to Master (MC-IP-ODC to MC-IP-ODC) or Master to Station (MC-IP-ODC to MC-IP-116), the MC-IP-HOST sees if that Station is available. If not, the requesting Station is sent a “Busy Signal”. If the Station is available a connection is established between the two devices and the ODC is in control of the conversation. If a remote Station pushes their call button a message is sent to the HOST requesting and intercom call. Any calling Station can be sent to one or more Operator Desk Consoles (ODCs) at the same time for answering this is known as a “Hunt Group”. This is configured for each Station. Call routing and feature options are stored in the MC-IP-HOST (HOST) for call processing.

### Call Processing

Calls are typically generated from a Station. When a Station places a call, a message is sent to the HOST for processing. Independent timers are assigned and started for each new call and the call is then put into the Call Queue. Depending on the calling Station configuration and the state of the MC System, the HOST rings the ODC’s that were configured for that Station. An ODC will only ring when they are able to take the call, i.e. the ODC and the MC-IP-116 (116) are not busy. An ODC is considered “busy” when it is in a page or on a call. A 116 is considered “busy” when any Station on a 116 is in a call. If any Station on a 116 is in a page, the 116 is not considered “busy”. In this case, an ODC will ring and can even connect the call, however, the page will override the call.

**Master to Master (ODC to ODC)** calling has two options which are configured for each ODC. An ODC can be “Automatic” meaning that if it is not busy, and another ODC wants to talk to it, the voice channel will automatically open as if the calling ODC had called a remote Stations such as a door or a cell. In this case the calling ODC is in control of the Push To Talk function and call ending. If Privacy is turned on, the receiving ODC will hear a beep tone before the calling ODC hears any audio. However, if an ODC is NOT set to “Automatic” any ODC calls will be processed as if a remote Station were calling and the receiving ODC will have to answer it. In this case the receiving ODC will ring. To answer the call, the receiving ODC will generate a call to the originating ODC. At this point the "receiving" ODC is now the master and normal ODC to ODC communications are handled as stated above.

### Call RELAY (what the Telephone Industry calls “Circular hunting”)

Call relaying is a feature which redirects a call to another ODC. In the MC-IP the Call Relay is configured for each Station with up to two RELAY ODC’s. The call processing for Call RELAY is determined by the configuration. The configuration is independent for each Station. There are four aspects to Call RELAY, Call Time Out, RELAY 1, RELAY 2, and RELAY Enable. See below for a better definition.

If a Station that is calling my ODC is relayed to You, and you are on a call, the call will still be pending for you, however, your ODC will not ring. Anytime a new CALL comes in an independent Relay timer is started.

If a CALL comes in to an ODC and the ODC is "busy" in a page or on a call, the new call is in the Queue and a message is sent to "their" system visually indicating the Call, but the ODC will not ring.

If a CALL comes in to an ODC and the 116 is "busy" in a call, the new call is in the Queue and a message is sent to "their" system indicating the Call, but the ODC will not ring. ODC's will only ring when they are able to take the call, i.e., the ODC and the 116 are not busy. When any Station on a 116 is in use, all Stations for that 116 are tagged as busy.

### **Call RELAY Processing**

When RELAY Enable has been configured, calls are placed in a hybrid "Circular hunting" loop. Depending on the configuration, a loop consists of up to three steps. The first is the initial Hunt Group of ODC's, the second is the RELAY 1 ODC, and the third is the RELAY 2 ODC. When a new call is placed, one of the timers that were assigned was the Call Time Out. If a call is unanswered for the duration of the timer, the call will advance through the loop and the timer will be reset. Once the end of the loop is reached the process starts over. Typically, during this process, only the active loop ODC(s) will ring, however, there is a configuration option (Ring Local) that will keep ringing the initial Hunt Group until the call is answered.

### **Call Forward All**

Is where the ODC is out of service for some reason and all calls are to be rerouted to another ODC. This is a system command that is set up in the control system (Touch Screen) so that the Operator can put their console out of service. When a console is out of service it just means that their calls will ring somewhere else. The visual call status is still broadcast to all control screens and can still be displayed as long as the touch screen is still on. It is suggested that the Touch Screen Icon be programmed to reflect that the ODC is in Call Forward All mode.

### **Call Forward Processing**

An ODC can only use forwarding if it has been configured to allow it. When a forward is created, it will only be created if it does not create an endless forward. For example, if ODC-a is forwarded to ODC-b, and ODC-b to ODC-c, and ODC-c to ODC-a, any call to any ODC would be in an endless loop and never ring anywhere. To avoid this, the system will not allow a new forward until a section of the loop is broken. In the example above, the last forward would fail. This means that any forward not needed should be removed before a new one is created. In the example above, the last forward was put in because ODC-a is back from lunch. So ODC-a to ODC-b would be canceled, then ODC-c to ODC-a created.

**Console Call Enables** (aka Hunt Groups) - Calls can be to a single ODC or to multiple ODCs in a Hunt Group. Hunt Groups on the MC-IP are set up for each Station and are not system wide.

# MC-IP Call Processing

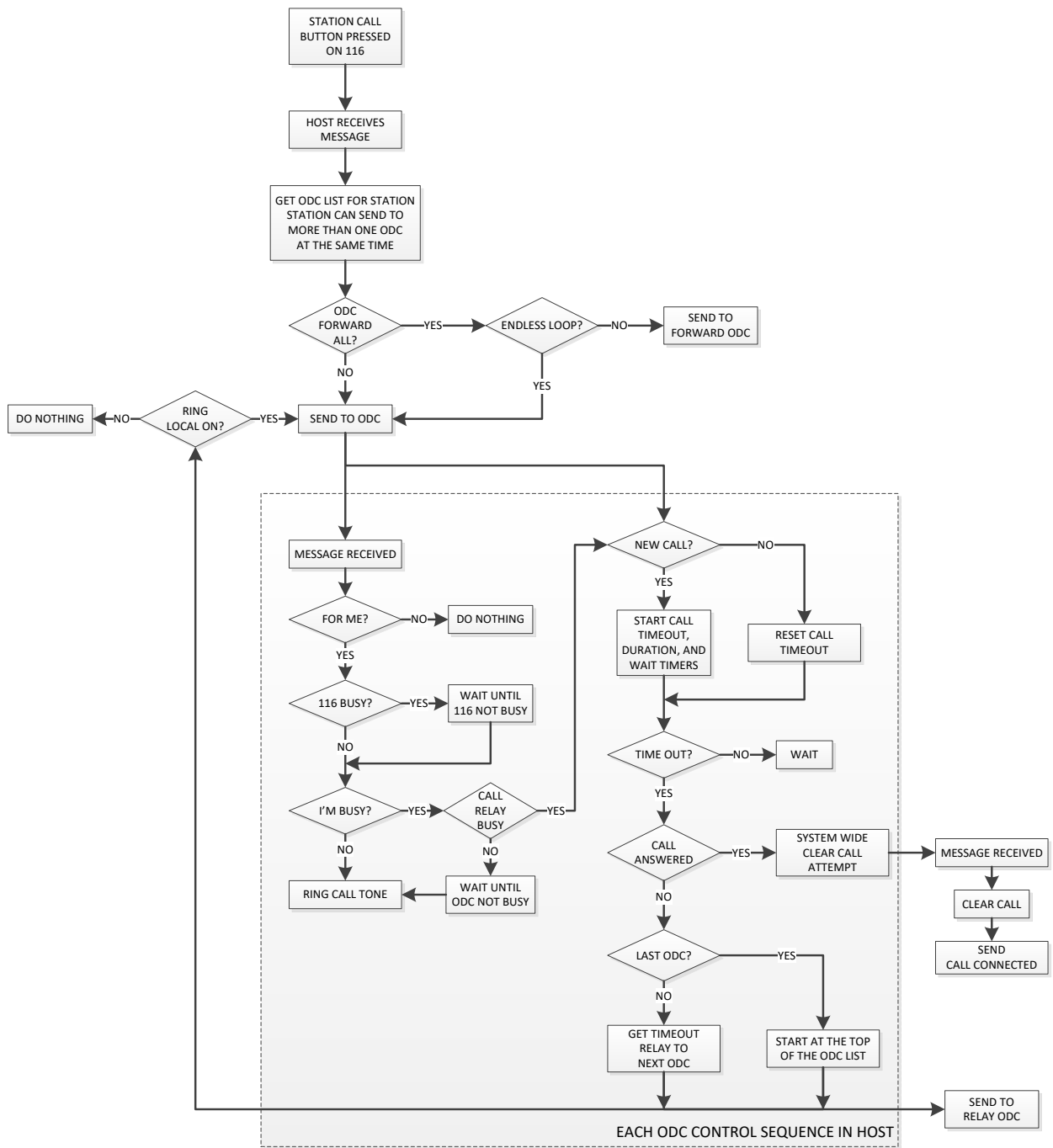

## MC-IP Configuration Utility

The MC-IP HOST and SERVER include an SD Card for storage of the system configuration. The SD Card is where the system configuration for this HOST or SERVER is stored. The reason for this is if there is ever a HOST or SERVER failure, the SD Card can be removed and installed in a new HOST and the new HOST or SERVER will read the SD Card on boot strap and will set the system up exactly as it was before.

By default, the SD card is blank and the HOST or SERVER will see that it has a blank SD card and boot to the system hardware defaults. The system hardware defaults are meant to allow a simple system to come up running with no programming required. The default is the first 2 MC-IP-116 (32 station) addresses will automatically call all of the first 4 MC-IP-ODC addresses with any call. All call tones and audio levels are by default set to the middle of their range. To change any of this, you need to use the Tech Works MC-IP Configurator Program. If you program one item and upload it to the system all other items will be blank. So, if you want to change one thing you have to program everything in the system. To help with this we make the default configuration available as an editable .mccfg file for your editing. This can be a good place to start your programming. The default configuration file is available on request from the factory.

Using the Tech Works MC-IP Configurator Program, create the system configuration you want to use and save it. You must use the MC Configuration software to load the Configuration into the HOST/SERVER SD Card. You can use the “Uploader” function built into the MC Configuration software if the computer running the Configurator software is connected to the MC-IP-HOST/SERVER network. The file is copied to the SD Card installed in a HOST/SERVER and the configuration will be read on boot strap (startup).

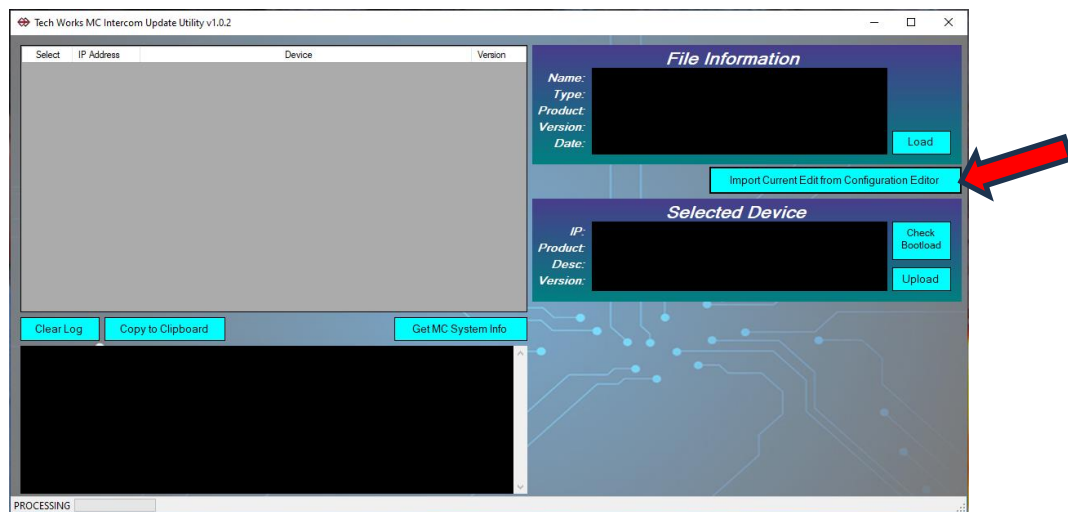

Be sure to save the file under the project and HOST name. Your file will be saved on your computer under that name followed by “.mccfg”. Simply copy this file to the Uploader and load it to a HOST/SERVER and it will send it to a formatted SD card. You can then remove the SD Card and archive it or swap the one in MC-IP- HOST/SERVER in the field. In this way, changes can be made by sending a technician out to the field without a computer.

The SD Card must be formatted to File System FAT32 for proper operation.

To set up your Modular Communication over Internet Protocol intercom system, a utility program is provided that will create and store your configuration. This program identifies all 32 MC-IP-ODC Operator Desk Consoles and how they will send and receive calls. Each ODC can also have up to 16 unique Paging Zones which are set up and assigned to each ODC in the Configuration Utility. It also Identifies all 32 MC-IP-116 Station Control Modules and all of their 16 Stations or all 64 MC-IP-MSI-11, and all of their calling attributes.

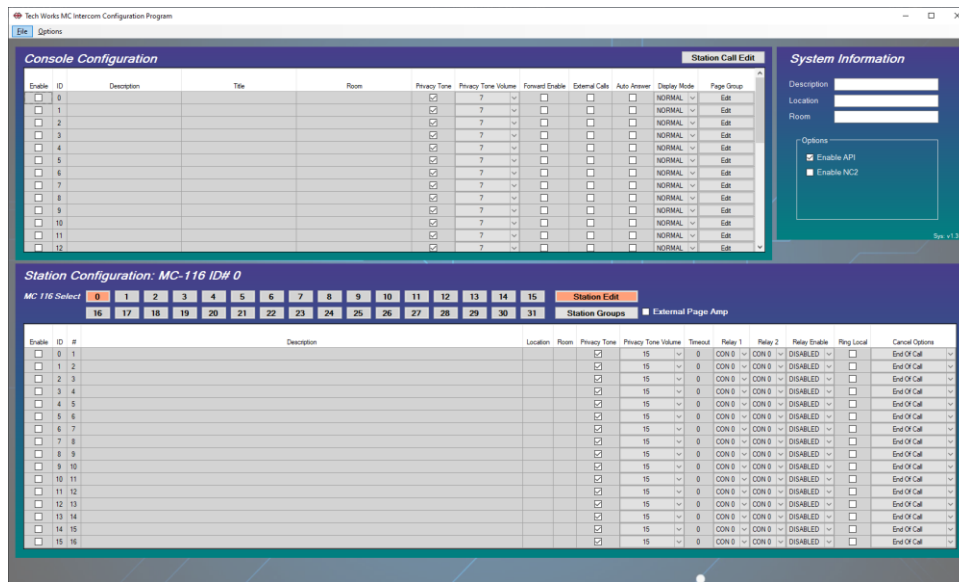

Begin by clicking on “Setup” and installing the “Tech Works MC Configurator. Application”. Once it is installed the above window will appear.

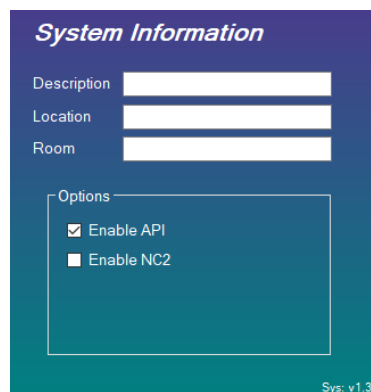

To start a new application, fill out the System Information screen and save your new configuration. When you “Save” your file you will be prompted for a “File” name, so the Description, Location, Room that you fill in is only for your reference and will not affect the file name.

The “Enable API” is a check box to indicate that this configuration will use the API commands to control the system.

The Enable NC2 is to activate the 2<sup>nd</sup> call point and indicator lights available with NC2 hardware. If this box is not check these features will not be available for programming and the 2<sup>nd</sup> button (Emergency Call) will not work on NC2 stations.

## Common Configuration Elements

### Programing Shortcuts

To facilitate faster programming, you can assign all of the Stations on a 116 or a group of MSIs to a Console by double clicking on the Console # at the top of the column and it will toggle all of the boxes in the vertical column below on or off. Double clicking the All column header will toggle on or off all of the enables for all of the Stations.

Column headers of any cell that is editable can be double clicked to help speed up programming. If a column is a check box, all values in the column will be toggled on or off.

Columns that are text, numbers, or contain drop down boxes, will open a window in which you can set the value for that column.

**All** is a button to assist in the selection of ODCs to receive call from this Station. By double clicking on the All button, all of the Console enables will toggle on or off for that selected Station. Green means selected.

**Privacy Tone Active** is an optional feature that inserts a tone every 10-20 seconds when a Station or ODC is being listened to. Privacy Tone (PT) is set for the end point of the call to alert the party being called that they are being listened to. If ODC-a calls ODC-b, a PT is used if ODC-b has it turned on. Same is true in regards to ODC to Station call. The end point, be it a Prison cell, Infirmary, Bathroom, Another Guard, or Teacher, can be individually configured for a PT or not.

The PT is ALWAYS echoed back to the calling ODC. So, if I call you, and you have PT on, when it beeps on your side, I hear it on my side. The PT is generated by the end point. This way there is no way for a Calling ODC to get messed up and NOT send the tone. Essentially, if someone is listening to me in the Bathroom, I will send the beep to them.

ODC to ODC calling is an option with any ODC. This is determined by how system connections are set up and allowed. An option is available to make sure that a particular ODC is never available to be called. In this way a Systems Integrator cannot inadvertently program a particular ODC to be listened to.

Paging is set in the ODC options. Group or Zone Paging is set for any group of Stations that are commonly paged at the same time. Each ODC can set up to 16 unique page Groups or Zones. Any Group can contain any combination of ODC and Remote Stations. Pages override a connected call. If Intercom Calls are happening between an ODC and Station, the Intercom Calls are muted while the Page happens. When the page is done, any muted call is restored and the PT is played immediately, if it is turned on for that end point. There can also be elevated priority Pages.

One of the 16-page groups can be set as an All-Page group for those Stations associated with a particular ODC.

**Interaction between ODC and another ODC or 116 or an MSI** is determined by how each one is programmed to act. The MC-IP-HOST is programmed using the Tech Works MC Configuration software. The following section describes how to use it. The Station Configuration screen below has 32 tabs across the top, one for each MC-IP-116 or MC-IP-MSI-11. Each 116 connects to up to 16 Stations While each MSI is a single station. Each screen shows the configuration of the 16 Stations connected to that 116 and the options for that Station. The MC-IP-MSI-11 64 station IDs will default to the 16 station configurations associated with the first 4 116 stations. In other words, MSI Network ID 0-15, IP Address 172.30.100.116 - 172.30.100.131, corresponds to MC-IP-116 “0”, station ID 0-15 for programming while MSI Network ID 16-31, IP Address 172.30.100.132 - 172.30.100.147, corresponds to MC-IP-116 “1”, station ID 0-15, while MSI Network ID 32-47, IP Address 172.30.100.148 - 172.30.100.163, corresponds to MC-IP-116 “2”, station ID 0-15, and MSI Network ID 48-63, IP Address 172.30.100.164 - 172.30.100.179, corresponds to MC-IP-116 “3”, station ID 0-15. So, in a mixed system using both MSIs and 116s you should start your Network IDs for the 116s at “4” to avoid conflicts.

**System Default Configuration** – All products ship are by default configured so that station addresses 1-32, the first 2 MC-IP-116, or first 32 MC-IP-MSI, and the first 4 MC-IP-ODC are active and configured to call each other. In other words when you open the box, if you simply plug them in and set the ID rotary switch of an MC-IP-116 to “0” or “1” and the MC-IP-ODC to “0” or “1” they will work as a system. ODC 0 and 1 will receive calls from stations 1-32 and can call each other.

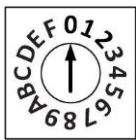

Each MC-IP-ODC, MC-IP-116, and MC-IP-MSI-11 have a rotary switch which assigns it a system Identification (ID) of 0-F (hex) which is 15. So, A=10, B=11, C=12, D=13, E=14, and F=15. To set the 116 to ID 16-31 you set the ID shift jumper P5 to “ON” and then set the rotary switch to 0=16, 1=17, 2=18, 3=19, 4=20, 5=21, 6=22, 7=23, 8=24, 9=25, A=26, B=27, C=28, D=29, E=30, F=31. The ID shift jumper and address switch are only read on “BOOT” Strap and that is when they receive their individual settings from the HOST. *If you change the address you must, **CYCLE POWER**.*

**Static protection such as static bracelets MUST be used at all times when any of the products are opened and vulnerable to electrostatic discharge.**

The installer sets the rotary switch at the time of installation to tell the system which Station Group it is. Once a MC-IP-ODC, MC-IP-116, or MC-IP-MSI-11 are connected to the MC-IP Network, the MC-IP-HOST automatically gets the ID and sends the configuration to the device. The device is now configured and ready to be used. The configuration for each device is set up in the HOST using the following screens.

First select the 116 or MSI that you wish to configure by clicking the tab at the top of the screen. The screen below is for setting up MC-IP-116 #0 which is technically the 1<sup>st</sup> system 116 because the first 116 is #0. You will see that the Station ID for those Stations associated with 116 #2 are 32-47. This is because the Station ID is assigned in sequence of 116 #0 = Station ID 0-15, 116 #1 = Station ID 16-31, 116 #2 = Station ID 32-47 and #3 = 48-63, etc., until MC-IP-116 #15 = Station ID 240-255. There are a total of 512 Stations and 32 ODCs per system. Station IDs are 0-511 and ODC IDs are 0-31.

Any Station can call any ODC or any combination of ODCs. Technically any ODC could call any Station but you would typically not set up a control screen for any Station or Page Zone that is not assigned to call an ODC. However, if a Central Command Control wanted to monitor all system activity, a screen could just as easily be set up to monitor all calls and Call any or all Stations.

## File Menu

In the upper left-hand corner is a standard Windows File Menu to allow basic file handling functions such as:

- New – Make a new configuration file
- Open – Open an existing configuration file for editing
- Save – To store the existing configuration
- Save As – To make a copy of the existing configuration under a new file name
- Exit – To close the Configurator Program

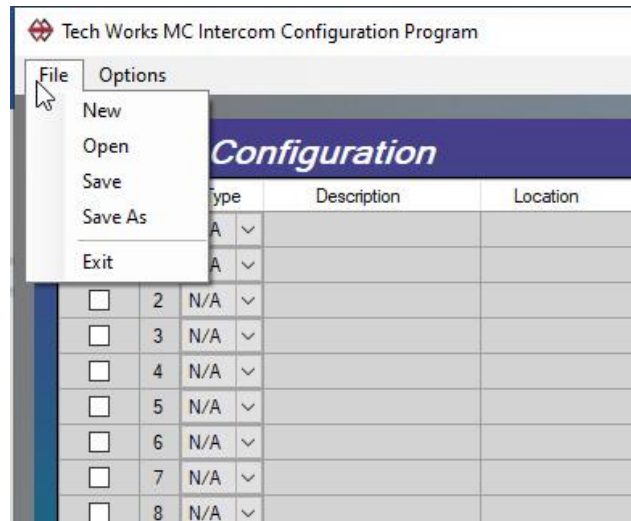

## Options Menu

- Also, in the upper left-hand corner is the Options menu.
- Auto Save feature automatically save your work every 5 minute.
  - Open Uploader – Software Updates Screen

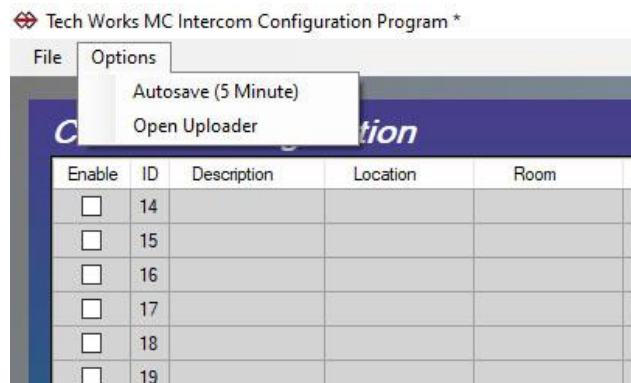

## Station Configuration

The Station Configuration is split into 2 screens to make programming easier. The button at the top right selects the screen you want to work on. The Station Edit Screen has 2 modes, depending on if you are editing a standard 116 or a 116-NC2.

**External Paging Amplifier** check box in programming is set for each 116 to tell it to either use the built in 20-watt amplifier or an external amplifier connected to the 116. If the External Paging Amplifier is set “On”, then each time the 116 is told to page it will automatically activate the built-in page relay and connect the External Amplifier screw terminal inputs to the Station select bus. If this feature is set to “Off” the built-in page relay will not activate and the internal 20-Watt amplifier will be used for paging program amplification.

## Station Edits

This is the standard 116 screen.



This is the 116-NC2 screen. Notice the NC2 check box. This box only appears if the NC2 check box on the “System Information” box is checked. This screen is used for a mixed system where some stations are connected to a standard MC-IP-116 and some are connected to an MC-IP-116-NC2. This screen gives the programmer the ability to not only set the basic call functionality but also the specific call cancel functions of the 2 call in buttons.

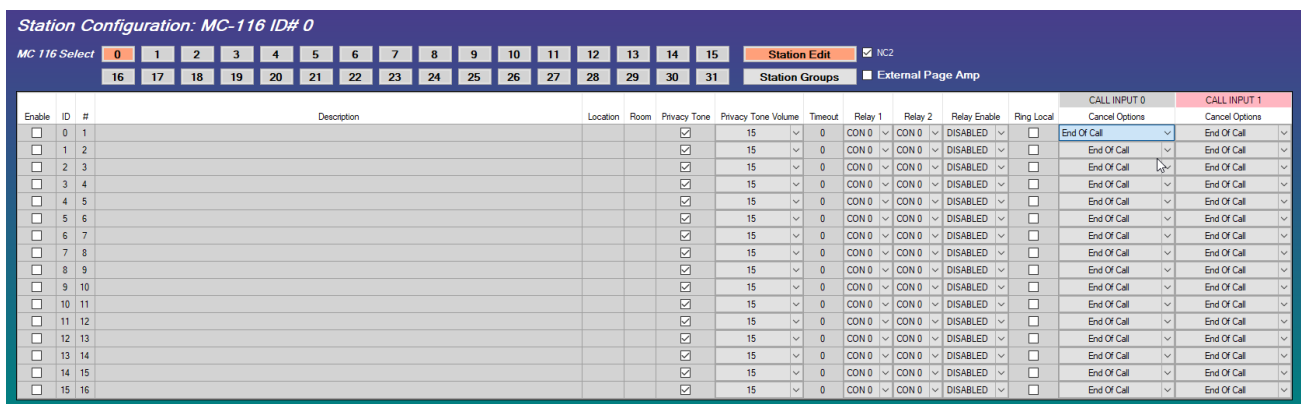

On the far right there are drop down menus for each of the 16 stations and each of the 2 call points for NC2.

The drop down Cancel Options are; End of Call, At Station, or Both, meaning that this call can be canceled at either the station or when the operator “End”s a call.

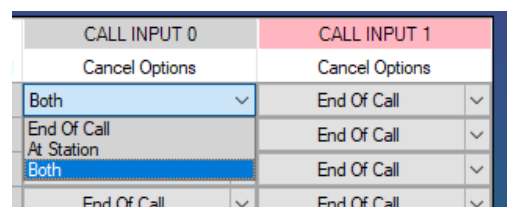

## Common Station Edits

Station Configuration: MC-116 ID# 0

MC 116 Select 0 1 2 3 4 5 6 7 8 9 10 11 12 13 14 15 Station Edit

16 17 18 19 20 21 22 23 24 25 26 27 28 29 30 31 Station Groups External Page Amp

Enable	ID	#	Description	Location	Room	Privacy Tone	Privacy Tone Volume	Timeout	Relay 1	Relay 2	Relay Enable	Ring Local	Cancel Options
<input type="checkbox"/>	0	1				<input checked="" type="checkbox"/>	15	0	CON 0	CON 0	DISABLED	<input type="checkbox"/>	End Of Call
<input type="checkbox"/>	1	2				<input checked="" type="checkbox"/>	15	0	CON 0	CON 0	DISABLED	<input type="checkbox"/>	End Of Call
<input type="checkbox"/>	2	3				<input checked="" type="checkbox"/>	15	0	CON 0	CON 0	DISABLED	<input type="checkbox"/>	End Of Call
<input type="checkbox"/>	3	4				<input checked="" type="checkbox"/>	15	0	CON 0	CON 0	DISABLED	<input type="checkbox"/>	End Of Call
<input type="checkbox"/>	4	5				<input checked="" type="checkbox"/>	15	0	CON 0	CON 0	DISABLED	<input type="checkbox"/>	End Of Call
<input type="checkbox"/>	5	6				<input checked="" type="checkbox"/>	15	0	CON 0	CON 0	DISABLED	<input type="checkbox"/>	End Of Call
<input type="checkbox"/>	6	7				<input checked="" type="checkbox"/>	15	0	CON 0	CON 0	DISABLED	<input type="checkbox"/>	End Of Call
<input type="checkbox"/>	7	8				<input checked="" type="checkbox"/>	15	0	CON 0	CON 0	DISABLED	<input type="checkbox"/>	End Of Call
<input type="checkbox"/>	8	9				<input checked="" type="checkbox"/>	15	0	CON 0	CON 0	DISABLED	<input type="checkbox"/>	End Of Call
<input type="checkbox"/>	9	10				<input checked="" type="checkbox"/>	15	0	CON 0	CON 0	DISABLED	<input type="checkbox"/>	End Of Call
<input type="checkbox"/>	10	11				<input checked="" type="checkbox"/>	15	0	CON 0	CON 0	DISABLED	<input type="checkbox"/>	End Of Call
<input type="checkbox"/>	11	12				<input checked="" type="checkbox"/>	15	0	CON 0	CON 0	DISABLED	<input type="checkbox"/>	End Of Call
<input type="checkbox"/>	12	13				<input checked="" type="checkbox"/>	15	0	CON 0	CON 0	DISABLED	<input type="checkbox"/>	End Of Call
<input type="checkbox"/>	13	14				<input checked="" type="checkbox"/>	15	0	CON 0	CON 0	DISABLED	<input type="checkbox"/>	End Of Call
<input type="checkbox"/>	14	15				<input checked="" type="checkbox"/>	15	0	CON 0	CON 0	DISABLED	<input type="checkbox"/>	End Of Call
<input type="checkbox"/>	15	16				<input checked="" type="checkbox"/>	15	0	CON 0	CON 0	DISABLED	<input type="checkbox"/>	End Of Call

**Enable** Tells the system that this Station is to be used.

**Station ID** is hard coded and set by the position of the rotary switch on the 116 as described above.

**Number** is the port number 1 of 16 where Stations connect on this 116.

**Description** is a description of the calling location connected to this port This is limited to 40 characters. If you are using a Tech Works MC-IP-ODC-TS Touch Screen console, this field will be what appears on the buttons of the Touch Screen. So be careful what you put in this field as the customer will see this on the Tech Works Touch Screen. The text space for each button is only 2 Lines/Button with 7 Characters of text per line, not 40 characters.

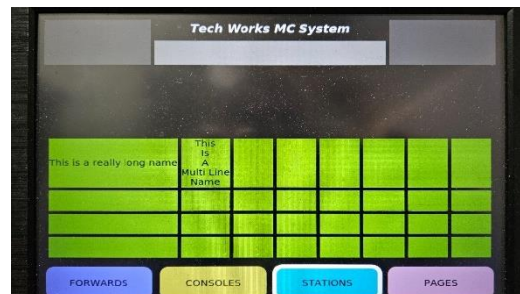
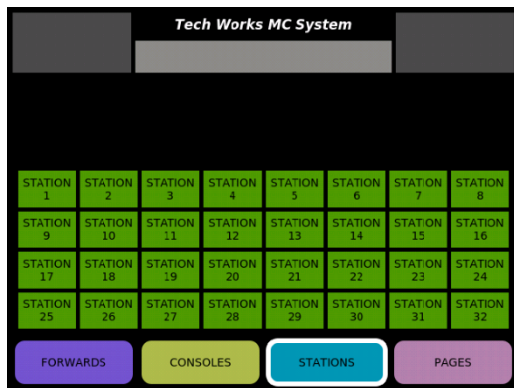

The buttons are dynamically created so that if you use too much text the screen will go wonky on you.

**Location** is a reference to a general area such as cell block or wing where the Station is located. This is limited to 30 characters.

**Room** is the actual Room or Cell number where the Station is located. This is limited to 10 characters.

**Privacy Tone** is a check box to enable the Privacy Tone whenever this Station is called.

**Privacy Tone Volume** sets the Privacy Tone level that comes out of the speaker into the room or cell where it is located. Level options are 0-15.

**Call Time Out** is the length of time that the system will wait to relay the call to another ODC.

A Relay is when a call is unanswered and a secondary answering location ODC rings with that call after some designated amount of time. On a Relayed Call the originally intended ODC will continue to ring even while the Relay ODC is ringing. The first ODC to answer will clear the call from the entire system. Relayed Calls are not Forwarded.

**Relay 1** is an ODC that calls from this Station should be Relayed to if calls are to be relayed.

**Relay 2** is another ODC that calls from this Station should be Relayed to if calls are to be relayed.

**Relay Enable** is how to route relay calls. There are 4 options:

1. **Relay 1** which means send relayed calls to the OCD designated as Relay 1 only.
2. **Relay 2** which means send relayed calls to the OCD designated as Relay 2 only.
3. **Both** which means send calls to both Relay 1 and Relay 2 as a Circular Hunt group. So, when a call is to be Relayed it will first send the call to Relay 1 and if the timer expires a second time it will then send the call to Relay 2.
4. **DISABLED** means that this Station will not Relay any calls to any other ODC.

**Ring Local** is a check box to designate if this Station is supposed to continue to ring throughout the relay process.

**Can Cancel** is the check box to designate if this station can cancel a call at the station by pressing the button a second time or not. When check this station “Can Cancel” it’s Call Ins.

## Station Groups

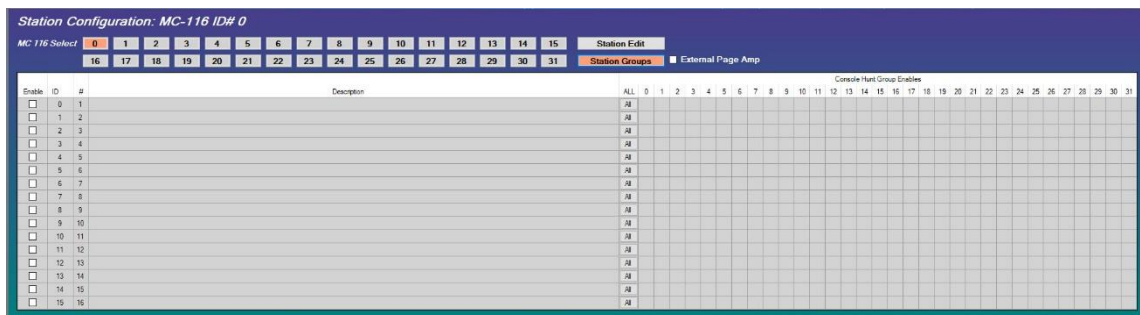

Station Groups are used to assign what ODC(s) will simultaneously ring when a call is first placed from this particular Station. When an ODC in the group picks up the call, the remaining ODC(s) in the group will have the call canceled for them and stop ringing.

**Enable** indicates if Hunting is allowed for this 116 Port when the box is checked.

**Console Hunt Group Enables** tells the 116 call point which ODC or ODCs to Ring. Select as many as you want.

**ALL** is a short cut that allows the programmer to quickly send this station’s calls to ALL 32 ODCs with the click of a single button.

Where each call Rings is unique to that Call Point.

## Console (ODC) Configuration



Each MC-IP-ODC has a rotary switch which assigns it a system Identification (ID) of 0-F (hex) which is 15. So, A=10, B=11, C=12, D=13, E=14, and F=15. To set the ODC to ID 16-31 you set the ID shift jumper P4 to “ON” and then set the rotary switch to 0=16, 1=17, 2=18, 3=19, 4=20, 5=21, 6=22, 7=23, 8=24, 9=25, A=26, B=27, C=28, D=29, E=30, F=31. The ID shift jumper and address switch are only read on “BOOT” Strap and that is when they receive their individual settings from the HOST. *If you change the address you must, **CYCLE POWER.***

**Static protection such as static bracelets MUST be used at all times when any of the products are opened and vulnerable to electrostatic discharge.**

The installer sets the rotary switch at the time of installation to tell system which Station Group it is. Once the ODC is connected to the MC-IP Network, the MC-IP-HOST automatically gets the ODC’s ID and sends the configuration to the ODC. The ODC is now configured and ready to be used. The configuration for each ODC is set up in the HOST using the following screens.

Console Configuration											Station Call Edit	
Enable	ID	Description	Title	Room	Privacy Tone	Privacy Tone Volume	Forward Enable	External Calls	Auto Answer	Display Mode	Page Group	
<input type="checkbox"/>	0				<input checked="" type="checkbox"/>	7	<input type="checkbox"/>	<input type="checkbox"/>	<input type="checkbox"/>	NORMAL	Edit	
<input type="checkbox"/>	1				<input checked="" type="checkbox"/>	7	<input type="checkbox"/>	<input type="checkbox"/>	<input type="checkbox"/>	NORMAL	Edit	
<input type="checkbox"/>	2				<input checked="" type="checkbox"/>	7	<input type="checkbox"/>	<input type="checkbox"/>	<input type="checkbox"/>	NORMAL	Edit	
<input type="checkbox"/>	3				<input checked="" type="checkbox"/>	7	<input type="checkbox"/>	<input type="checkbox"/>	<input type="checkbox"/>	NORMAL	Edit	
<input type="checkbox"/>	4				<input checked="" type="checkbox"/>	7	<input type="checkbox"/>	<input type="checkbox"/>	<input type="checkbox"/>	NORMAL	Edit	
<input type="checkbox"/>	5				<input checked="" type="checkbox"/>	7	<input type="checkbox"/>	<input type="checkbox"/>	<input type="checkbox"/>	NORMAL	Edit	
<input type="checkbox"/>	6				<input checked="" type="checkbox"/>	7	<input type="checkbox"/>	<input type="checkbox"/>	<input type="checkbox"/>	NORMAL	Edit	
<input type="checkbox"/>	7				<input checked="" type="checkbox"/>	7	<input type="checkbox"/>	<input type="checkbox"/>	<input type="checkbox"/>	NORMAL	Edit	
<input type="checkbox"/>	8				<input checked="" type="checkbox"/>	7	<input type="checkbox"/>	<input type="checkbox"/>	<input type="checkbox"/>	NORMAL	Edit	
<input type="checkbox"/>	9				<input checked="" type="checkbox"/>	7	<input type="checkbox"/>	<input type="checkbox"/>	<input type="checkbox"/>	NORMAL	Edit	
<input type="checkbox"/>	10				<input checked="" type="checkbox"/>	7	<input type="checkbox"/>	<input type="checkbox"/>	<input type="checkbox"/>	NORMAL	Edit	
<input type="checkbox"/>	11				<input checked="" type="checkbox"/>	7	<input type="checkbox"/>	<input type="checkbox"/>	<input type="checkbox"/>	NORMAL	Edit	
<input type="checkbox"/>	12				<input checked="" type="checkbox"/>	7	<input type="checkbox"/>	<input type="checkbox"/>	<input type="checkbox"/>	NORMAL	Edit	

**Enable** is a check box that tells the system that this ODC is to be used.

**Station ID** is hard coded and set by the position of the rotary switch on the ODC as described above.

**Description** is the description of the hardware and how it is being used. This is limited to 40 characters.

**Title** is a reference to a general area such as cell block or wing where the Operator Console Station is located. This is limited to 30 characters. If this programming is being use with a **MC-IP-ODC-TS** touch screen station, the text that is entered here will appear at the top of the Touch Screen. If this field is left blank the words “**Tech Works MC System**” will appear at the top of the console screen.

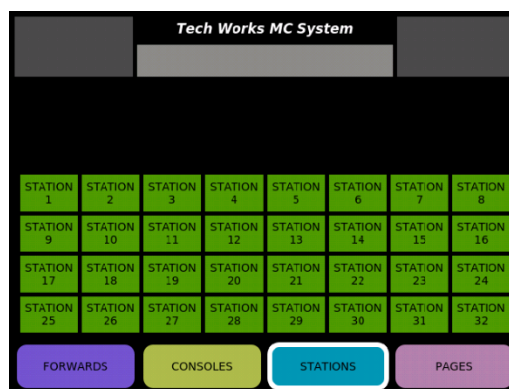

Console Configuration											Station Call Edit	
Enable	ID	Description	Title	Room	Privacy Tone	Privacy Tone Volume	Forward Enable	External Calls	Auto Answer	Display Mode	Page Group	
<input type="checkbox"/>	0				<input checked="" type="checkbox"/>	7	<input type="checkbox"/>	<input type="checkbox"/>	<input type="checkbox"/>	NORMAL	Edit	
<input type="checkbox"/>	1				<input checked="" type="checkbox"/>	7	<input type="checkbox"/>	<input type="checkbox"/>	<input type="checkbox"/>	NORMAL	Edit	
<input type="checkbox"/>	2				<input checked="" type="checkbox"/>	7	<input type="checkbox"/>	<input type="checkbox"/>	<input type="checkbox"/>	NORMAL	Edit	
<input type="checkbox"/>	3				<input checked="" type="checkbox"/>	7	<input type="checkbox"/>	<input type="checkbox"/>	<input type="checkbox"/>	NORMAL	Edit	
<input type="checkbox"/>	4				<input checked="" type="checkbox"/>	7	<input type="checkbox"/>	<input type="checkbox"/>	<input type="checkbox"/>	NORMAL	Edit	
<input type="checkbox"/>	5				<input checked="" type="checkbox"/>	7	<input type="checkbox"/>	<input type="checkbox"/>	<input type="checkbox"/>	NORMAL	Edit	
<input type="checkbox"/>	6				<input checked="" type="checkbox"/>	7	<input type="checkbox"/>	<input type="checkbox"/>	<input type="checkbox"/>	NORMAL	Edit	
<input type="checkbox"/>	7				<input checked="" type="checkbox"/>	7	<input type="checkbox"/>	<input type="checkbox"/>	<input type="checkbox"/>	NORMAL	Edit	
<input type="checkbox"/>	8				<input checked="" type="checkbox"/>	7	<input type="checkbox"/>	<input type="checkbox"/>	<input type="checkbox"/>	NORMAL	Edit	
<input type="checkbox"/>	9				<input checked="" type="checkbox"/>	7	<input type="checkbox"/>	<input type="checkbox"/>	<input type="checkbox"/>	NORMAL	Edit	
<input type="checkbox"/>	10				<input checked="" type="checkbox"/>	7	<input type="checkbox"/>	<input type="checkbox"/>	<input type="checkbox"/>	NORMAL	Edit	
<input type="checkbox"/>	11				<input checked="" type="checkbox"/>	7	<input type="checkbox"/>	<input type="checkbox"/>	<input type="checkbox"/>	NORMAL	Edit	
<input type="checkbox"/>	12				<input checked="" type="checkbox"/>	7	<input type="checkbox"/>	<input type="checkbox"/>	<input type="checkbox"/>	NORMAL	Edit	

**Room** is the actual Room number where the hardware is located. **This is limited to 10 characters.**

**Privacy Tone** is a check box to enable the Privacy Tone whenever this Station is called.

**Privacy Tone Volume** sets the Privacy Tone level that comes out of the speaker into the room or cell where it is located. Level options are 0-15 with 0 being the lowest.

**Forward Enable** is a check box that determines if this ODC can forward its calls to another ODC. If the box is checked, the systems integrator can add a Call Forward.

**External Calls** means this ODC can get a call from another ODC.

**Auto Answer** means if an ODC calls this ODC, if ON it connects automatically, If OFF it rings and then this ODC "accepts the call".

**Display Mode** is a drop-down menu only used with the MC-IP-ODC-TS Touch Screen model. The menu options are "Normal", "Simple", Compact, and Simple Compact.

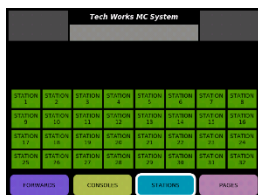
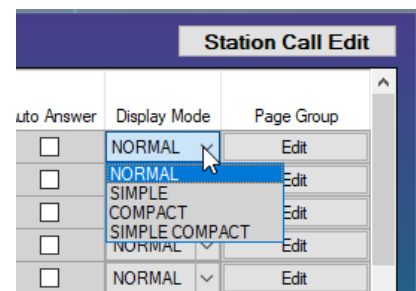

**Normal Mode** gives the user access to all system stations and functions assigned to it.

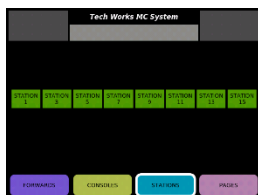

**Simple Mode** gives the user a smaller menu screen for use with smaller systems.

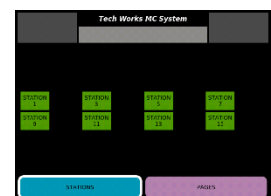

**Compact Mode** eliminated any unused stations that are not Active so the user only see real stations

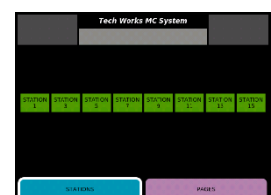

**Simple Compact Mode** is a combination of the Simple operating Command and the Active stations

**Page Group Edit** takes the programmer to a separate screen to set up the paging details for each ODC.

**Page Group Configuration** is a separate screen used to set up a group of Stations that are commonly paged at the same time. Each ODC has the ability to set up 16 (0-15) separate Page Groups/Zones that are unique to that ODC. Most of the time an ODC has Stations that they page that are not tied to any other ODC. However, a central command control location may want to Page multiple ODC areas including ODCs.

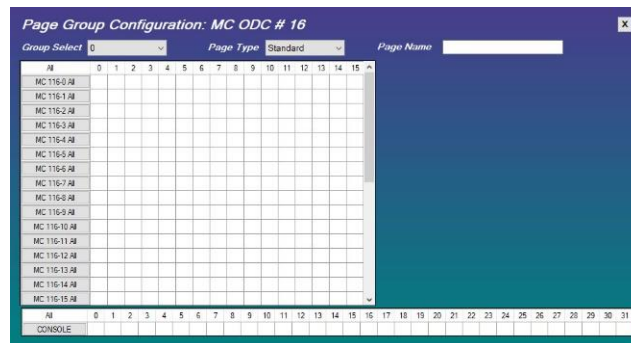

**Group Select**, up at the top left is a drop-down menu which represents the Zone you want to create 0-15.

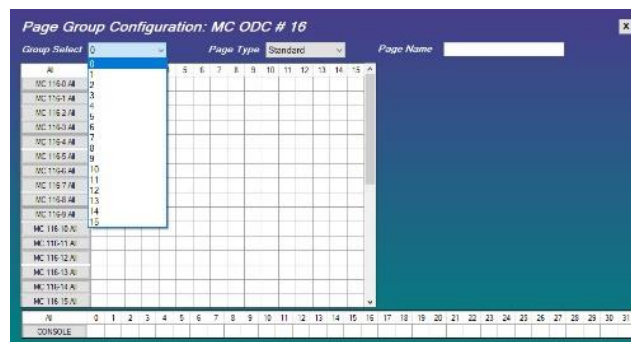

**“Page Type”** select:

**Override Page** will override any other Stations call or page currently in process by putting current calls on hold while Priority page occurs and restoring them when it ends.

**Standard Page** will override local intercom calls, placing them on hold until the Page ends, but will not override other Page calls.

**Page Name** For convenience you can give each Page Group a name to identify it.

To select the stations to include in a Group you can individually click on each station box associated with each MC-IP-116. Or to select all station on a particular 116 you can just double click on the 116 buttons at the left.

Repeat to create up to 16 Groups/Zones for each ODC.

Typically, Zone “0” is used to set a Zone that represents “All Call” on a particular ODC.

**Console** allows you to add ODCs to include in this Group by selecting them individually or All by double clicking the Console button.

## Station Call Edits

This is where you set how a call “Rings” at the operator location. The list on the left is the 32 ODCs.

Again, there are 2 set up screens for this function; one for standard 116 and one for 116-NC2 because the second call point should ring differently from the first call point. There are up to 3 types of Calls per Console. The 2<sup>nd</sup> call point only appears for programming if the NC2 Check box is Checked

**Call Input 0** is the first and only call input on a standard MC-IP-116 so it is not labeled on the Standard screen. This is a Normal Call on NC2

Console Configuration							Station Call Edit		
Enable	ID	Description	CALL INPUT 0			CONSOLE CALLS			
			Call Volume	Reminder	Ringtone	Call Volume	Reminder	Ringtone	
<input type="checkbox"/>	0		7	<input type="checkbox"/>	0	7	<input type="checkbox"/>	2	
<input type="checkbox"/>	1		7	<input type="checkbox"/>	0	7	<input type="checkbox"/>	2	
<input type="checkbox"/>	2		7	<input type="checkbox"/>	0	7	<input type="checkbox"/>	2	
<input type="checkbox"/>	3		7	<input type="checkbox"/>	0	7	<input type="checkbox"/>	2	
<input type="checkbox"/>	4		7	<input type="checkbox"/>	0	7	<input type="checkbox"/>	2	
<input type="checkbox"/>	5		7	<input type="checkbox"/>	0	7	<input type="checkbox"/>	2	
<input type="checkbox"/>	6		7	<input type="checkbox"/>	0	7	<input type="checkbox"/>	2	
<input type="checkbox"/>	7		7	<input type="checkbox"/>	0	7	<input type="checkbox"/>	2	
<input type="checkbox"/>	8		7	<input type="checkbox"/>	0	7	<input type="checkbox"/>	2	
<input type="checkbox"/>	9		7	<input type="checkbox"/>	0	7	<input type="checkbox"/>	2	
<input type="checkbox"/>	10		7	<input type="checkbox"/>	0	7	<input type="checkbox"/>	2	
<input type="checkbox"/>	11		7	<input type="checkbox"/>	0	7	<input type="checkbox"/>	2	
<input type="checkbox"/>	12		7	<input type="checkbox"/>	0	7	<input type="checkbox"/>	2	

**Call Input 1** is the second call (Emergency Call) input available on the MC-IP-116-NC2.

Console Configuration							Station Call Edit				
Enable	ID	Description	CALL INPUT 0			CALL INPUT 1			CONSOLE CALLS		
			Call Volume	Reminder	Ringtone	Call Volume	Reminder	Ringtone	Call Volume	Reminder	Ringtone
<input type="checkbox"/>	0		7	<input type="checkbox"/>	0	7	<input type="checkbox"/>	1	7	<input type="checkbox"/>	2
<input type="checkbox"/>	1		7	<input type="checkbox"/>	0	7	<input type="checkbox"/>	1	7	<input type="checkbox"/>	2
<input type="checkbox"/>	2		7	<input type="checkbox"/>	0	7	<input type="checkbox"/>	1	7	<input type="checkbox"/>	2
<input type="checkbox"/>	3		7	<input type="checkbox"/>	0	7	<input type="checkbox"/>	1	7	<input type="checkbox"/>	2
<input type="checkbox"/>	4		7	<input type="checkbox"/>	0	7	<input type="checkbox"/>	1	7	<input type="checkbox"/>	2
<input type="checkbox"/>	5		7	<input type="checkbox"/>	0	7	<input type="checkbox"/>	1	7	<input type="checkbox"/>	2
<input type="checkbox"/>	6		7	<input type="checkbox"/>	0	7	<input type="checkbox"/>	1	7	<input type="checkbox"/>	2
<input type="checkbox"/>	7		7	<input type="checkbox"/>	0	7	<input type="checkbox"/>	1	7	<input type="checkbox"/>	2
<input type="checkbox"/>	8		7	<input type="checkbox"/>	0	7	<input type="checkbox"/>	1	7	<input type="checkbox"/>	2
<input type="checkbox"/>	9		7	<input type="checkbox"/>	0	7	<input type="checkbox"/>	1	7	<input type="checkbox"/>	2
<input type="checkbox"/>	10		7	<input type="checkbox"/>	0	7	<input type="checkbox"/>	1	7	<input type="checkbox"/>	2
<input type="checkbox"/>	11		7	<input type="checkbox"/>	0	7	<input type="checkbox"/>	1	7	<input type="checkbox"/>	2
<input type="checkbox"/>	12		7	<input type="checkbox"/>	0	7	<input type="checkbox"/>	1	7	<input type="checkbox"/>	2

**Console Calls** are calls from other Operator Consoles.

**Call Volume** determines how loud the Call Ringing tone will be on this ODC. Level options are 0-15 with 0 being the lowest.

**Reminder** is a check box to allow the operator to receive a tone from the console speaker if a call is pending while another call is active. This tone is delayed after the call is placed and rings only if the call is ignored.

**Ring Tone** is the actual sound heard from the console speaker when this call is pending. There are a variety of built in tones available so that each call type is easily identified.

## Programming an MC-IP-MSI-11 address

Programming the MSI can get a little confusing. Let's start with the station ID and IP address.

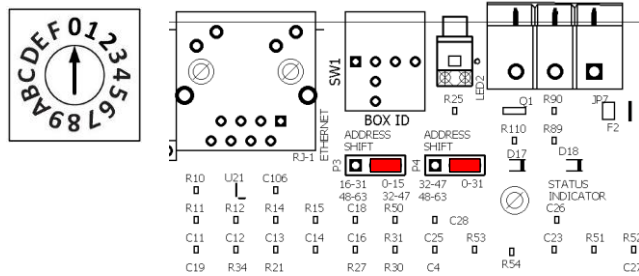

With both shift jumpers to the right or OFF position the station ID rotary switch sets the station ID to 0-15, IP Address 172.30.100.116 - 172.30.100.131, corresponds to MC-IP-116 “0”, station ID 0-15 for programming.

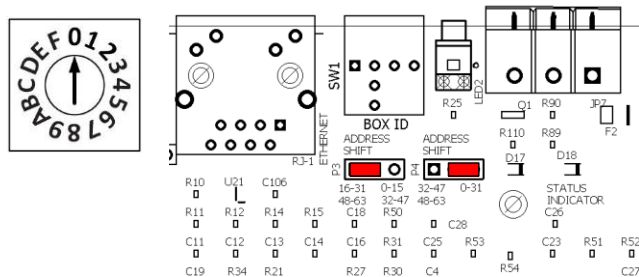

With shift jumper P3 to the left and P4 to the right the station ID rotary switch sets the station ID to 16-31, IP Address 172.30.100.132 - 172.30.100.147, corresponds to MC-IP-116 “1”, station ID 0-15 for programming.

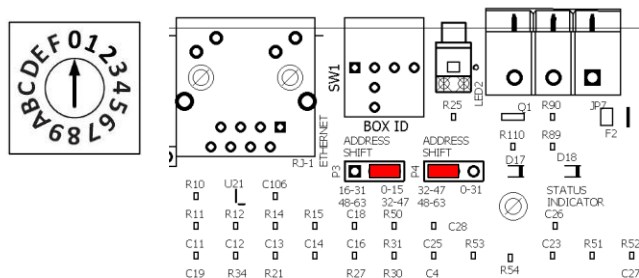

With shift jumper P3 to the right and P4 to the left the station ID rotary switch sets the station ID to 32-47, IP Address 172.30.100.148 - 172.30.100.163, corresponds to MC-IP-116 “2”, station ID 0-15 for programming.

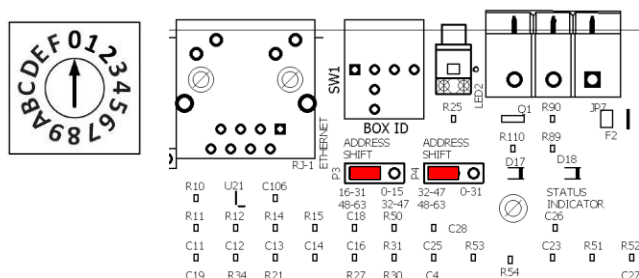

With shift jumper P3 and P4 both to the left the station ID rotary switch sets the station ID to 48-63, IP Address 172.30.100.164 - 172.30.100.179, corresponds to MC-IP-116 “3”, station ID 0-15 for programming.

## Programming an MC-IP-MSI-11 Configuration

Let's say that you have 11 of the MC-IP-MSI-11 that all want to call 2 Operator MC-IP-ODC-TS. You would set the configuration like this:

The screenshot shows the 'Tech Works MC Intercom Configuration Program - KSUMosier' interface. It is divided into three main sections:

- Console Configuration:** A table with columns: Enable, ID, Description, Title, Room, Privacy Tone, Privacy Tone Volume, Forward Enable, External Calls, Auto Answer, Display Mode, and Page Group. Rows 0 and 1 are selected. Row 0: Nurses Station, Room 120, Privacy Tone 7. Row 1: Anesthesia, Room 121, Privacy Tone 7.
- Station Configuration: MC-116 ID# 0:** A grid for configuring 16 stations (ID 0-15). The 'MC 116 Select' row shows stations 0-15. The 'Station Groups' row shows 'Station Groups' selected. The grid has columns for 'Console Hunt Group Enables' (0-31) and rows for station descriptions (OR1A-OR5B, Ophthalmology, Anesthesia, Recovery).
- System Information:** Fields for Description (KSU Mosier Hall), Location (Small Animal Clinic), and Room (C119). Options for 'Enable API' and 'Enable NC2' are visible.

If you wanted to set up an All Page from ODC #1 you would do it like this:

The screenshot shows the 'Page Group Configuration: MC ODC # 1' window. It includes a 'Group Select' dropdown (0), a 'Page Type' dropdown (Standard), and a 'Page Name' field (All Page). The main area is a grid for configuring page groups for stations 0-15. The grid has columns for stations 0-15 and rows for page group names (MC 116-0 All to MC 116-15 All). The 'All' row shows green boxes for stations 0-10. The 'CONSOLE' row shows a green box for station 0.

This calls All station plus the other Console

## To Upload the Configuration

1. Install the “Tech Works MC Configurator” application and open it.
2. Create a configuration and save the file.
3. Open the “Uploader” by clicking on the “Options” tab and “Open Uploader”.

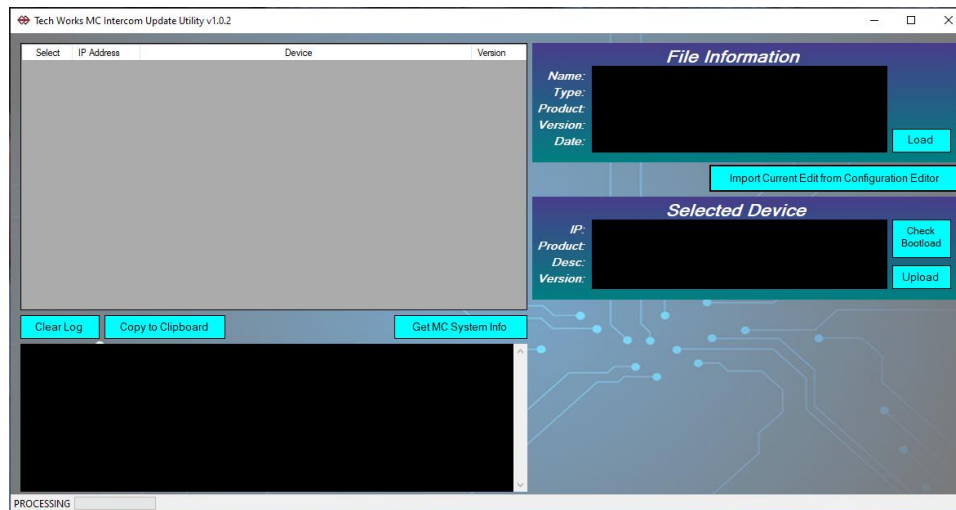
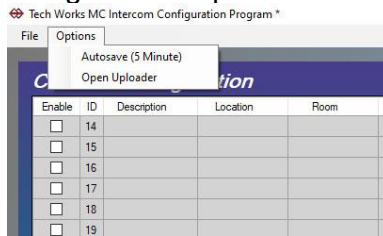

4. Select “GET MC System Info” to see the devices available for Upload.
5. Click “Import Current Edit from Configuration Editor”
6. If the file matches network device it will be hi-lighted in Yellow. Select the HOST from the list of devices and it will appear in the “Selected Device” window.
7. Click the “UPLOAD” button to transfer the file.
8. Once a message “Configuration Transfer Complete” is received, the HOST will push the update out to the ODC’s and 116’s within about a second or two.

## To load Firmware Updates

Once the Initial Firmware is loaded, you can upload future updates by doing the same thing as above but selecting a device and the firmware you want to load.

1. Select “GET MC System Info” to see the devices available for Upload.
2. Click “Load File” and select the Firmware file you want to load.
3. If the file matches network device they will be hi-lighted in Yellow. Select the device you want to load and it will appear in the “Selected Device” window.
4. Click the “UPLOAD” button to transfer the file.
5. Once a message “Programming Complete” appears the device will restart to load the new firmware and acquire it’s configuration from the HOST or SERVER.

## MC-IP-SERVER Configuration

When you add MC-IP-SERVERs to a system, they reside on both the local network as a HOST and on the WAN as a communication SERVER to connect one local network to another. Each SERVER is configured using the Tech Works MC-Configurator Software just like a HOST as described above.

### WHEN MULTIPLE SYSTEMS NEED TO BE TIED TOGETHER THE MC-IP-SERVER PROVIDES CALL ROUTING BETWEEN INTERCOM SYSTEMS

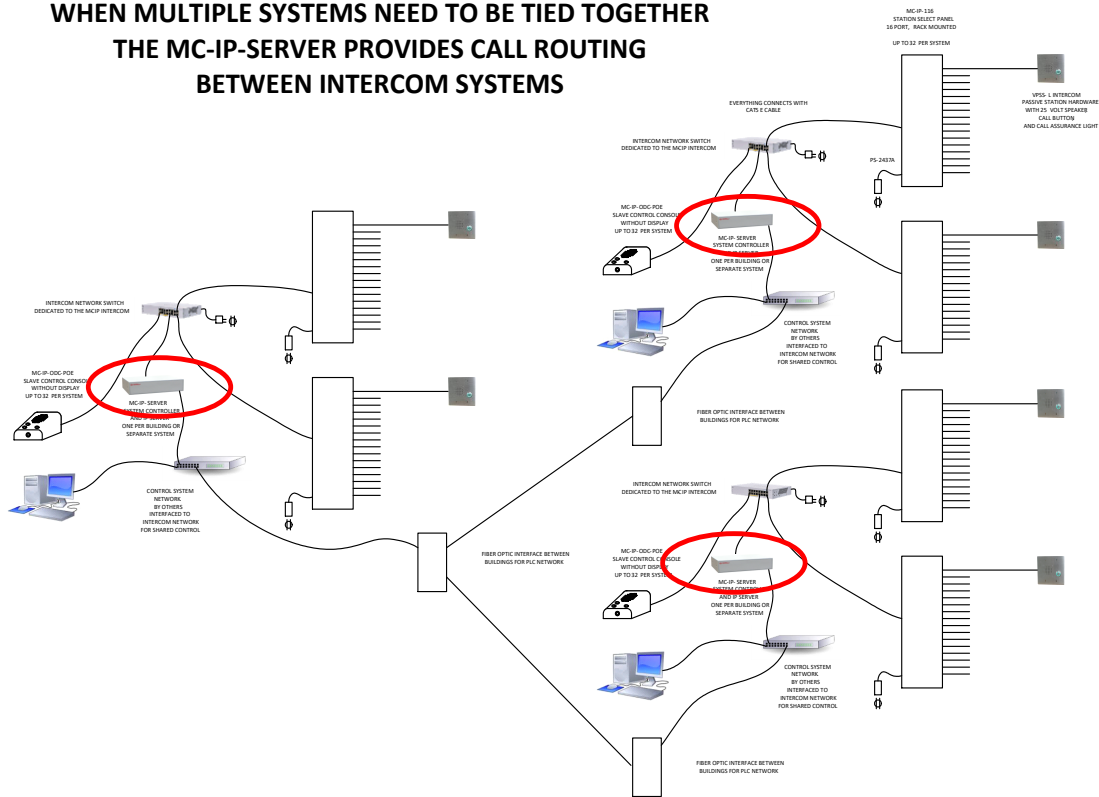

Once you have each separate system configured, you need to configure the SERVER itself to reside on your WAN network. To do this, simply plug a monitor, keyboard and mouse into a SERVER. The monitor will display this Default Screen.

TECH WORKS - MC Server - ID # 0

**MC Network**  
 IP Address: 172.30.100.2  
 Subnet Mask: 255.255.255.0  
 Gateway: 172.30.100.1

**WAN Network**  
 IP Address: 192.168.1.97  
 Subnet Mask: 255.255.255.0  
 Gateway: 192.168.1.1

FIRMWARE VERSION: 2.0.0

**WAN NETWORK SETTINGS**

IP: 192 . 168 . 1 . 97  
 SUBNET: 255 . 255 . 255 . 0  
 GATEWAY: 192 . 168 . 1 . 1  
 SERVER ID: 0

SAVE

8/28/22 - 3:04:56 pm

SERVER LIST

ID	Enabled	IP Address	Description
0	<input checked="" type="checkbox"/>	192.168.1.97	Default Settings
1	<input checked="" type="checkbox"/>	192.168.1.98	West Wing
2	<input type="checkbox"/>		
3	<input type="checkbox"/>		
4	<input type="checkbox"/>		
5	<input type="checkbox"/>		
6	<input type="checkbox"/>		
7	<input type="checkbox"/>		
8	<input type="checkbox"/>		
9	<input type="checkbox"/>		
10	<input type="checkbox"/>		
11	<input type="checkbox"/>		
12	<input type="checkbox"/>		
13	<input type="checkbox"/>		
14	<input type="checkbox"/>		
15	<input type="checkbox"/>		
16	<input type="checkbox"/>		
17	<input type="checkbox"/>		
18	<input type="checkbox"/>		
19	<input type="checkbox"/>		
20	<input type="checkbox"/>		
21	<input type="checkbox"/>		
22	<input type="checkbox"/>		
23	<input type="checkbox"/>		
24	<input type="checkbox"/>		
25	<input type="checkbox"/>		
26	<input type="checkbox"/>		

SAVE SERVER INFO

## WAN NETWORK SETTINGS

The MC-IP-SERVER WAN network settings are totally flexible and follow all network setup standards. You can set the WAN networks to any IP address, Subnet, and Gateway that meets your network needs. The MC-Network settings are fixed to make local network setup easy, while the WAN is totally up to you.

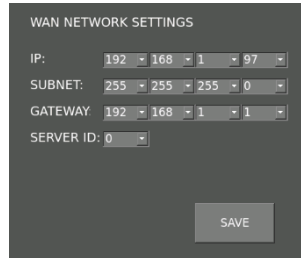

The screenshot shows a configuration window titled "WAN NETWORK SETTINGS". It contains five rows of dropdown menus for IP, SUBNET, GATEWAY, and SERVER ID. The IP is set to 192.168.1.97, SUBNET to 255.255.255.0, and GATEWAY to 192.168.1.1. A "SAVE" button is located at the bottom right.

Select and assign an IP Address to this SERVER

Set the Subnet to be compatible with your network

Set your network Gateway

Now you need to assign this SERVER so it can find other SERVERS on the WAN and so that it can be found.

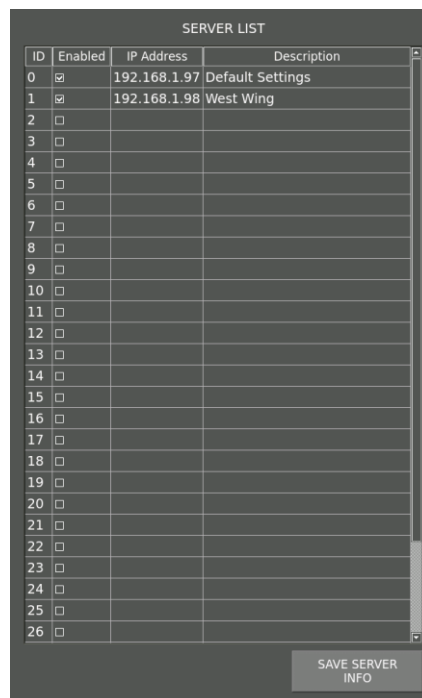

The screenshot shows a "SERVER LIST" window with a table of 27 servers. The first two servers are enabled and have IP addresses and descriptions. A "SAVE SERVER INFO" button is at the bottom right.

ID	Enabled	IP Address	Description
0	<input checked="" type="checkbox"/>	192.168.1.97	Default Settings
1	<input checked="" type="checkbox"/>	192.168.1.98	West Wing
2	<input type="checkbox"/>		
3	<input type="checkbox"/>		
4	<input type="checkbox"/>		
5	<input type="checkbox"/>		
6	<input type="checkbox"/>		
7	<input type="checkbox"/>		
8	<input type="checkbox"/>		
9	<input type="checkbox"/>		
10	<input type="checkbox"/>		
11	<input type="checkbox"/>		
12	<input type="checkbox"/>		
13	<input type="checkbox"/>		
14	<input type="checkbox"/>		
15	<input type="checkbox"/>		
16	<input type="checkbox"/>		
17	<input type="checkbox"/>		
18	<input type="checkbox"/>		
19	<input type="checkbox"/>		
20	<input type="checkbox"/>		
21	<input type="checkbox"/>		
22	<input type="checkbox"/>		
23	<input type="checkbox"/>		
24	<input type="checkbox"/>		
25	<input type="checkbox"/>		
26	<input type="checkbox"/>		

Check the "ENABLE" box for the SERVERS to exist on this system.

Set the IP for each SERVER Enabled.

Add a brief Description to identify each SERVER (Housing Unit A, B, etc.)

Hit "SAVE SERVER INFO" to store the settings and the SERVER will Reboot with the new settings.

Your done with this SERVER. Repeat for all SERVERS. Your done. It's that easy.

On the SERVER home screen there are 2 buttons in the upper right-hand corner.

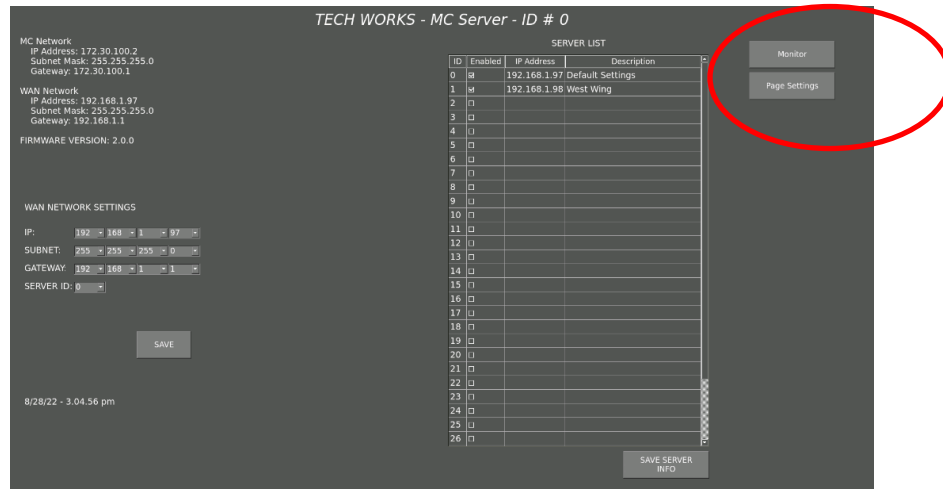

By clicking on the “Monitor” button you will be taken to the following screen

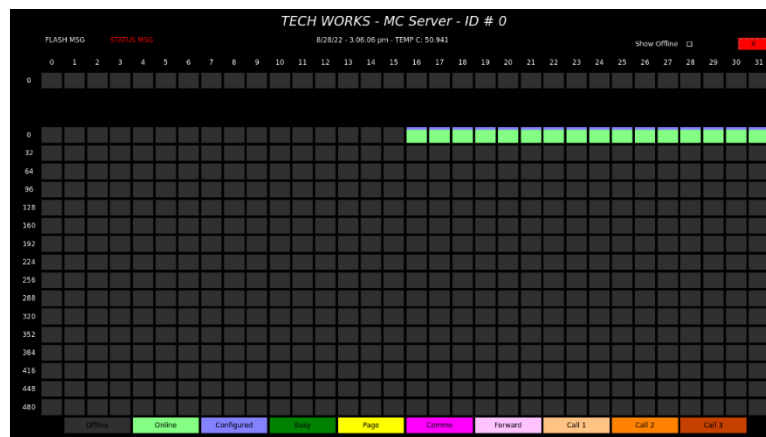

This screen shows you the status of device connected to this SERVER. The icons across the bottom of the screen are simply a legend to identify what the meaning of the colors are of the station information above. This particular SERVER has one MC-IP-116 connected and configured as stations 16-31 which correspond to rotary switch setting “1”. The active boxes being green indicates that all 16 stations are configured and active or “Online”. If a station was busy, it’s box would change to Dark Green. If a station was being Paged it would be Yellow.

***This is simply a way to monitor the system for diagnostic purposes only. This takes a lot of systems resources and will kill the SERVER if left active. Do not monitor a SERVER for more than just a few minutes to avoid shut down. This is for DIAGNOSTIC use ONLY!***

## Global Paging

Paging across SERVERS is done a bit differently than local paging. By clicking on “Page Settings” you will be taken to this screen:

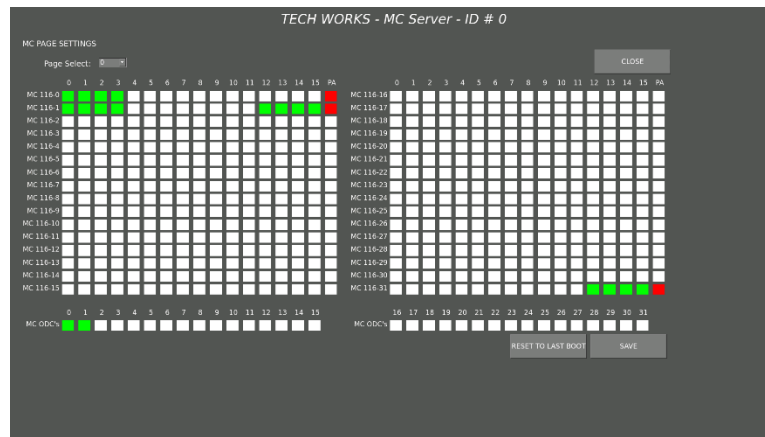

**Global Page Group Configuration** is a separate screen used to set up a group of Stations that are commonly paged at the same time. Each SERVER has the ability to set up 16 (0-15) separate Page Groups/Zones that are unique to that SERVER. Most of the time a SERVER has Stations that are allowed to be paged that are unique to that building or system such as Exercise Yards or Common areas. However, a central command control location may want to Page multiple areas including ODCs.

In simple Local HOST paging an Operator Console sets up its individual page zones or Groups. When using SERVERS, each SERVER has Page Groups which are accessible from remote SERVERS. So just like you set up ODC Page Groups in the MC-Configuration software, you set up Global Page groups for this SERVER. What you do is create a page group on each server with whatever stations/ODC's that you want to Page. This page group setting is local to each server. Then you send a “Global Page” command at the source server and pass the page group and a mask of what servers are to get the page.

**Group Select**, up at the top left is a drop-down menu which represents the Zone you want to create 0-15.

To select the stations to include in a Group you can individually click on each station box associated with each MC-IP-116. Or to select all station on a particular 116 you can just double click on the 116 buttons at the left.

Repeat to create up to 16 Groups/Zones for each SERVER.

Typically, Zone “0” is used to set a Zone that represents “All Call” on a particular SERVER.

**PA**, is the far-right hand box in each row and stands for “Pre-Announce Tone”. By clicking this box a beep tone will be sent before each Global page begins.

**Console** allows you to add ODCs to include in this Group by selecting them individually or All by double clicking the Console button.

**Reset to Last Boot**, will set this SERVER to what it was set to before you started.

**Save**, don't forget to save your settings before continuing.

**Close**, will take you back to the main SERVER Home Screen

## External Control System API

An API can be used when Systems Integrators want to use a separate touch screen control console that is also used for things like door control, lighting, and cameras. If external control is to be used, it is highly recommended that a router be used to isolate the MC-IP network from any other network. Only the necessary ports and traffic should be allowed to pass through the router as needed. If a router is used, it should NOT be configured as a DHCP server. The LAN IP settings of the router should be the following:

IP: 172.30.100.1  
MASK: 255:255:255:0  
Subnet: 172.30.100.1

The HOST is able to be controlled through ASCII based commands sent via TCP at IP address 172.30.100.2 on port 60000. Commands are structured in the format of [**command source destination \r\n**]. HOST response commands are structured similar but have a response designation at the start of the message [**response**] [**original command**].

Commands received by the HOST will be responded to in the following ways. Any command that is an invalid command will be returned with a **Fail** response. Any command that is a valid command will be returned with an **Ackd** response. The one exception is that a valid command can be sent to the Host and it could return a **Busy** response. This would happen if the command sent is not possible to be acted upon. An example of this, is that if a 116 has a Station in communication and I want to talk to it, I would get back a **Busy** response as the Host is unable to connect the call. These return responses are followed by the original command.

Example:

If a command of **Hello 0 0 \r\n** is sent, the return response would be **Fail Hello 0 0 \r\n**.

If a command of **Ical 0 9 \r\n** is sent, then the return response would be either **Ackd Ical 0 9 \r\n** or **Busy Ical 0 9 \r\n**, depending on the "busy" state of the ODC and the Station.

If a command of **Ical 9 \r\n** is sent, then the return response would be **Fail Ical 9 \r\n** , since the value 2 is missing.

Specific API commands from the MC-IP-HOST will be sent to the control system indicating what is going on with the Intercom. The control system will send specific API commands to tell the MC-IP-HOST what to do. Each command is followed by an ODC-ID (O), Station-ID (S), and/or PageGroup (P) and a carriage return (\r) and line feed (\n). The commands are structured as [Command] space [Source] space [Destination] space [\r\n]

When a station presses a button a lcrq [ODC] [station] is sent to all ODC's it has been configured for. When an ODC answers the call by sending a lcal [ODC] [station], a lcan [ODC] [station] is sent to all the pending ODC's and a lcom [ODC] [station] is sent to indicate who took the call. When the call is done a lend [ODC] [station] is sent.

When you communicate over a system using SERVERs the commands are the same as when using a HOST on a simple system. The difference is the message needs to include a little more information so that the system knows who wants to talk to whom. More on this later.

## API Command List

The following is a list of the commands made available for integrators to use to communicate with the MC-IP system. Some command formats are for communication with a HOST and others are for communication with a SERVER.

Command	Description
List	Internal Usage
Time	Use Socket Timer
Toff	Disable Socket Timer
<b>Hrst</b>	<b>Hardware Reset</b>
Arst	Reset All Calls
Firm	Show Firmware
Asta	Get all ODC and Station Status Bits
Msta	Get all ODC Status Bits
Ista	Get all Station Status Bits
Ilst	List Station Calls
Plst	List Active Pages
P3lst	List Active Pages 3 value mode
Mlst	List Console Calls
Flst	List of Forwards
Irst	Reset All Station Calls
Mrst	Reset All Console Calls
Prst	Reset All Pages
Info	List versions and last digit of IP
Ical	Call Station
Ical	Call ODC to Station across servers
Iend	End Station Call
Iend	End Call ODC to Station across servers
Mcal	Call Console
Mcal	Call ODC to ODC across servers
Mend	End Console Call
Mend	End Call ODC to ODC across servers
Pcal	Start Page
Pcal	Start Page with PA Buss force
Pend	End Page
Pend	End Page with PA Buss force
Fset	Create Forward
Frst	Remove Forward
Mmut	Mute = 1, Mute the Ringing Mute = 0, Turn Mute Off
GPcal	Start Server page with mask indicating what servers to page N number
GPend	End Server page with mask indicating what servers to page N number

When doing ODC to ODC calls, the process is essentially the same. The one difference is in the Mcal and Mcrq because an ODC can be configured to not auto answer. If a Mcal is sent and the destination ODC is not configured to auto answer, a normal Ackd response will be returned and a Mcrq will be generated. And the ODC will ring. A Mcal will then need to be sent from the original destination ODC to connect the call.

Example:

ODC 1 calls ODC 2 and ODC 2 has the auto answer turned off.

Outgoing: Mcal [ODC1] [ODC2]

Incoming: Ackd Mcal [ODC1] [ODC2]

Incoming: Mcrq [ODC1] [ODC2]

ODC 2 would be ringing.

To connect the call;

Outgoing: Mcal [ODC2] [ODC1]

Incoming: Ackd Mcal [ODC2] [ODC1]

Incoming: Mcom [ODC2] [ODC1]

A typical call sequence might be:

1. Station #26 tries to call ODC #2 and a system message is sent from the MC-IP-HOST, "lcrq 02 26\r\n", which makes the Icon on the touch screen labeled Station #26 start to flash and the console to ring.
2. ODC #2 answers the call by pressing the Icon on the touch screen labeled Station #26 which sends the system message to the MC-IP-HOST, "lcal 02 26 \r\n", and changes the touch screen Icon to a different color and on steady, not flashing. This opens the voice channel between the ODC #2 and Station #26 and they have a conversation.
3. The ODC #2 ends the connection by pressing the Icon for Station #26 which sends the system message to the MC-IP-HOST, "lend 02 26 \r\n", and changes the touch screen Icon to its inactive state and color.

## API Command Details

**"lcal" – Intercom Call** - When an ODC wants to talk to a Station.

Command: lcal O S \r\n // Connect comms O to S

Response: Ackd lcal O S, lcom O S (If the call is connected)

Note a lcom O S may also be sent if call was generated by a station and an lcrq is pending"

Example: lcal 02 47\r\n

This would be where Operator ODC #2 tries to connect to Station #47

**"lend" – Intercom Call End** - When an ODC wants to disconnect or "end" a call to a Station.

Command: lend O S \r\n // End call/comms O to S

Response: Ackd lend O S

Example: lend 02 47\r\n

This would be where Operator #2 ends the connection to Station #47

**"lcrq" – Intercom Call Request** - When a Station places a call to an ODC.

Command: lcrq O S \r\n // A call from S for O is generated by the MC-IP-116.

Example: lcrq 00 29\r\n

This would be where Station #29 places a call to Operator #0

**“Ican” – Intercom Call Canceled** - When a Station cancels a call to an ODC.

Command: Ican O S \r\n // A call from S for O

Example: Ican 00 29\r\n

This would be where Station #29 cancels a call to Operator #0

**“Mcal” – Master to Master Call** – When an ODC wants to call another ODC.

Command: Mcal O O \r\n // Connect comms O to O

Response: Ackd Mcal O O, Mcon O O (If the call is connected)

Example: Mcal 03 12 \r\n

This would be where Operator ODC #3 tries to connect to ODC #12

**“Mend” – Master to Master Call End** – When an ODC wants to end a currently active call to another Master.

Command: Mend O O \r\n // End call/comms O to O

Response: Ackd Mend O O

Example: Mend 03 12 \r\n

This would be where Operator ODC #3 ends the connection to ODC #12

**“Pcal” – Page Call** – When an ODC wants to Page a Page Group / Zone.

Command: Pcal O P \r\n // Connect Page O to page group P

Response: Ackd Pcal O P

Example: Pcal 08 15 \r\n

This would be where Operator ODC #8 establishes a Page to Group/Zone #15

**“Pend” – Page End** – When an ODC wants to end a Page.

Command: Pend O P \r\n // End Page O to group P

Response: Ackd Pend O P

Example: Pend 08 15 \r\n

This would be where Operator ODC #8 ends a Page to Group/Zone #15

**“Fset” – Forward All Calls** – When an ODC wants to go out of service and Forward All Calls to a different Operator Console.

Command: Fset O O \r\n // Forward O to O

Response: Ackd Fset O O

Example: Fset 04 5 \r\n

This would be where Operator ODC #4 forwards all of its calls to ODC#5

**“Frst” – Forward All Reset** – When an ODC wants to go back into service and end Call Forward All.

Command: Frst O O \r\n // Cancel Forward O to O

Response: Ackd Frst O O

Example: Frst 04 5 \r\n

This would be where Operator ODC #4 Resets or cancels call forward to ODC#5

A set of “List” commands have been added to show the current active calls and forwards. These commands do not require any additional values to be sent.

“**l1st**” - **Intercom List** - List of all active ODC to Station calls.

Command: l1st \r\n

Response: l1oa [ODC] [STATION] \r\n

“**l1st**” – **Master List** - List of all active ODC to ODC calls.

Command: M1st \r\n

Response: M1oa [ODC source] [ODC destination] \r\n

“**flst**” – **Forward List** - List of all active forwards.

Command: Flst \r\n

Response: Floa [ODC source] [ODC destination] \r\n

Responses have been added to help with understanding why a command was not able to be processed. Here are the following responses.

“**Npos**” – **Forward Not Possible** - This is sent when a forward is not possible.

If an attempt to create new forward that would create an endless loop were to be sent, a Npos response would be sent indicating that the forward is not possible at this time.

“**Ncon**” – **No Connection Possible** - This is sent when an action is not allowed due to the configuration.

If the configuration was set for ODC1 to not accept external calls and someone attempted to call it, a Ncon response would be sent indicating that ODC1 is not configured to allow this action.

## SERVER API

When you communicate over a system using SERVERs the commands are the same as when using a HOST on a simple system. All of the previous information in this manual applies to systems using MC-IP-SERVERs. All of the Commands are the same. The difference is the message needs to include a little more information so that the system knows who wants to talk to whom.

Remember that basic commands are structured as:

[Command] space [Source] (Console) space [Destination] (Station) space [\r\n] where “\r” is a carriage return and “\n” line feed.

The difference when SERVERS are involved is, what SERVER is the [Source] connected to and what SERVER is the [Destination] connected to? So, the message becomes:

[Command] space [CON SERVER] space [Source] (Console) space [STA SERVER] space [Destination] (Station) space [\r\n]

So, to place a call would look like this:

lcal 00 02 01 15

This would be a call from SERVER 0, Console 2 to SERVER 1 Station 15

In other words, the local HOST message lcal 02 01 15 would become lcal 00 02 01 15

## Global Page API

The command for a global page is:

```
GPcal [ODC] [SERVER PAGE GROUP] [SERVER MASK]\r\n
```

Broken down:

GPcal = Global Page call

[ODC] = The local ODC that is the source of the page

[SERVER PAGE GROUP] = the page group that will be used for all servers

[SERVER MASK] = a binary mask for what servers to include.

Here is an example of the bit value for the servers as you can see the mask value doubles at each server ID incrementation.

SERVER ID	Mask Value	Binary	Hex
0	1	00000001	0x01
1	2	00000010	0x02
2	4	00000100	0x04
3	8	00001000	0x08
4	16	00010000	0x10
5	32	00100000	0x20
6	64	01000000	0x40
7	128	10000000	0x80

To give you an idea of the usage I will explain a single "All call" page.

Example:

I will go to page settings on each server, select page 0, and assign all stations/ODC's in use on the server. I would repeat this for all my servers. Now we can think of this as page group 0 as an all page. Assuming we have 4 servers (0,1,2,3) and I want to do an all page from ODC-7 on SERVER-X, and I want to include all servers. I would calculate the mask by adding the Mask Value of each server, so in the case of server 0,1,2,3 I would add 1,2,4,8. So my mask would = 15.

From SERVER-X my command would be:

```
GPcal 7 0 15\r\n;
```

Using the same settings, say I only wanted to send the page to SERVER-0 and SERVER-3. The command would be:

```
GPcal 7 0 9\r\n;
```

Here is the list of Global Page commands:

```
GPcal [ODC] [SERVER PAGE GROUP] [SERVER MASK]\r\n = Global Page Call
```

```
GPend [ODC] [SERVER PAGE GROUP] [SERVER MASK]\r\n = Global Page End
```

Responses:

```
GPend [ODC] [SERVER PAGE GROUP] [SERVER MASK]\r\n = Global Page Ended
```

```
GPcom [ODC] [SERVER PAGE GROUP] [SERVER MASK]\r\n = Global Page Connected
```

**Tech Works OMRON Library 1.0.1**  
 File: Tech Works MC-IP Interface\_r04-02-25a.slr

Tech Works, working in conjunction with Omron, has created an OMRON Sysmac Studio Library to make integration between the MC-IP Intercom and OMRON NX series PLC easier. The library is available on request from Tech Works. This document will describe how the MC-IP-SERVER library can be used.

Once installed this is what a typical OMRON NX PLC application would look like.

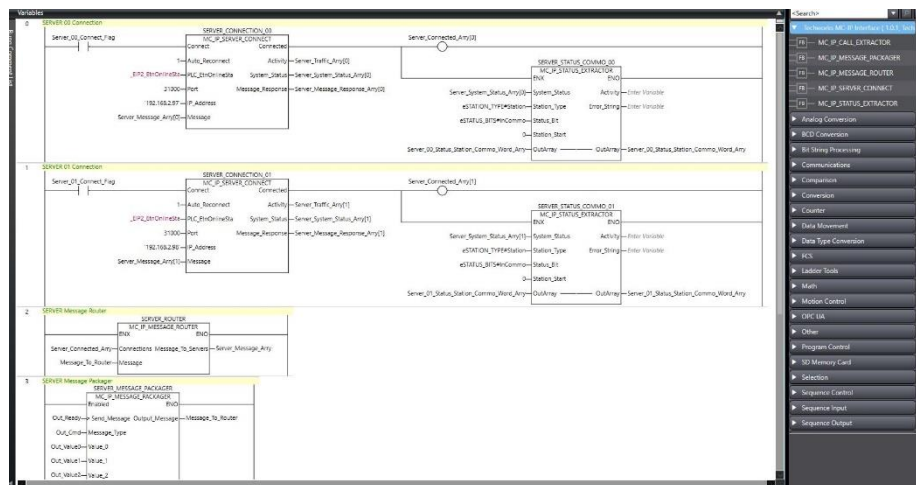

Messages that are passed to/from the SERVER are done through various variables that may utilize structures and enumerated values. Enumerated values are prefaced with a lowercase “e” whereas structures are prefaced with a lowercase “s”.

**Enumerated Values** **Description**

eMESSAGE_TYPES	Defines the type of message being sent/received
eSTATUS_BITS	Bit mask used to extract particular values from status messages
eSTATION_TYPE	Defines the type of station. Station or Master

**Structures** **Member** **Description** **Type**

sMESSAGE		Message Payload	
	Cmd	Message Type	eMESSAGE_TYPES
	Value0	Value 0	UDINT
	Value1	Value 1	UDINT
	Value2	Value 2	UDINT
	Value3	Value 3	UDINT
sMESSAGE_SEND		Message Send Structure	
	Send	Flag to send the message	BOOL
	Send_Message	Message Payload	sMESSAGE
sSTATUS_BITS		Node Bits received from the status message	
	OnLine	Node is Online	BOOL
	Configured	Node is Configured	BOOL
	Busy	Node is Busy	BOOL
	InCommo	Node is In a Call	BOOL

	InPage	Node is In an active Page	BOOL
	CallBit0	Node is Calling Bit 0	BOOL
	CallBit1	Node is Calling Bit 1	BOOL
	Forwarded	Node is Forwarded	BOOL
	Misc	Reserved for future use	BYTE
sSTATUS_MSG		System Status Message	
	Cmd	Message Type	eMESSAGE_TYPES
	SationInfo	Array of Sation Status Bits	ARRAY[0..511] OF sSTATUS_BITS
	ConsoleInfo	Array of Console Status Bits	ARRAY[0..31] OF sSTATUS_BITS
	ActiveCalls	Array of Console Calls	ARRAY[0..31] OF sSTATUS_CALL_INFO
	CheckSum	Message Check Sum	UDINT
sSTATUS_CALL_INFO_BITS		Call Information Bits	
	InCommo	Node is In a Call	BOOL
	Spare6	Reserved for future use	BOOL
	Spare5	Reserved for future use	BOOL
	Spare4	Reserved for future use	BOOL
	Spare3	Reserved for future use	BOOL
	Spare2	Reserved for future use	BOOL
	Spare1	Reserved for future use	BOOL
	Spare0	Reserved for future use	BOOL
	Misc	Reserved for future use	BYTE
sSTATUS_CALL_INFO		Call Information	
	Call_Info_Bits	Call Information Bits	sSTATUS_CALL_INFO_BITS
	SrcServerID	Call Server Source ID	BYTE
	DestNodeType	Call Node Destination Type	eSTATION_TYPE
	DestServerID	Call Server Destination ID	BYTE
	DestNodeID	Call Node Destination ID	WORD
sMESSAGE_RESPONSE		Message Response	
	Cmd	Message Type	eMESSAGE_TYPES
	Value0	Value 0	UDINT
	Value1	Value 1	UDINT
	Value2	Value 2	UDINT
	Value3	Value 3	UDINT
	Status	Status Value	UDINT

There are 5 function blocks within the library:

1. MC\_IP\_SERVER\_CONNECT
2. MC\_IP\_MESSAGE\_PACKAGER
3. MC\_IP\_MESSAGE\_ROUTER
4. MC\_IP\_STATUS\_EXTRACTOR
5. MC\_IP\_CALL\_EXTRACTOR

## MC\_IP\_SERVER\_CONNECT:

This function block is used to connect to the SERVER and passes messages to and from the PLC to the SERVER. This function block only handles a single SERVER; you will need to use one for every SERVER that the PLC will be connecting to.

### MC\_IP\_SERVER\_CONNECT Function Block Variables

Name	In/Out	Type	Description
Connect	IN	BOOL	When TRUE, the PLC will connect to the SERVER
Auto_Reconnect	IN	BOOL	When TRUE, the PLC will reconnect to the SERVER should it loose communication.
Port	IN	UINT	This is the Port used on the SERVER for communication. This should be set to 31000
IP_Address	IN	STRING	This is the WAN IP Addressw of the SERVER
Message	IN	sMESSAGE_SEND	The message structure that will be sent from the PLC to the SERVER
Connected	OUT	BOOL	This will be TRUE when the SERVER has established a connection
Activity	OUT	BOOL	This will toggle everytime a message is sent to the SERVER either from the Message input or messages sent within the module.
System_Status	OUT	sSTATUS MSG	This is the system status from the SERVER.
Message_Response	OUT	sMESSAGE_RESPONSE	Message returned from the SERVER when a message is sent. This is generally used for diagnostic purpose.

## MC\_IP\_MESSAGE\_PACKAGER

This function block is used to package up a message to be sent by setting the message type to be sent and the required message values. The message will be sent on the rising edge of the Send\_Message input.

*MC\_IP\_MESSGAE\_PACKAGER Function Block Variables*

Name	In/Out	Type	Description
Enable	IN	BOOL	Enable the function block
Send_Message	IN	BOOL	When TRUE, the PLC will connect to the SERVER
Message_Type	IN	eMESSAGE_TYPES	Type of message to be sent
Value_0	IN	UDINT	Value 0 Of message *
Value_1	IN	UDINT	Value 1 Of message *
Value_2	IN	UDINT	Value 2 Of message *
Value_3	OUT	UDINT	Value 3 Of message *
ENO	OUT	BOOL	Always High
Output_Message	OUT	sMESSAGE_SEND	Packaged message to be sent to the SERVER

\* The Values(0-3) are message dependent and follow the standard formatting of the SERVER API commands.

## MC\_IP\_MESSAGE\_ROUTER

This function block is optional; however, it is meant to be used to simplify sending messages by routing it to the appropriate SERVER when using arrays. When a message is created using the packager, it needs to be sent to the appropriate SERVER. For example, an lcal 1 2 3 4 means that we want to call from SERVER\_01 CONSOLE\_02 to SERVER\_03, STATION\_04. This message MUST be packaged and sent to either SERVER\_01 or SERVER\_02. The router helps with this by looking at the first SERVER value and moving the message to an array that corresponds to the SERVER's.

*MC\_IP\_MESSGAE\_ROUTER Function Block Variables*

Name	In/Out	Type	Description
ENX	IN	BOOL	Enable the function block
Connections	IN	ARRAY[0..31] OF BOOL	SERVER connection flags
Message	IN	sMESSAGE_SEND	Packaged Message to Send
ENO	OUT	BOOL	Always High
Message_To_Servers	OUT	ARRAY[0..31] OF sMESSAGE_SEND	Message Output for Server[x]

## MC\_IP\_STATUS\_EXTRACTOR

This function block extracts an array of a status bit from the system status message and assembles them into a bit representation word array. The first bit of the word array starts with the value of the Status\_Bit at the Station\_Start value and will fill to the size of the array. This is best

Status\_Bit = InCommo

Station\_Start = 0

WORD	0								1							
BIT	0	1	2	3	//	13	14	15	0	1	2	//	13	14	15	
STATION InCommo	0	1	2	3	//	13	14	15	16	17	18	//	29	30	31	

Status\_Bit = InCommo

Station\_Start = 3

WORD	0								1							
BIT	0	1	2	3	//	13	14	15	0	1	2	//	13	14	15	
STATION InCommo	3	4	5	6	//	16	17	18	19	20	21	//	32	33	34	

### MC\_IP\_STATUS\_EXTRACTOR Function Block Variables

Name	In/Out	Type	Description
ENX	IN	BOOL	Enable the function block
System_Status	IN	sSTATUS_MSG	System status message from SERVER
Station_Type	IN	eSTATION_TYPE	Station type to extract from
Status_Bit	IN	eSTATUS_BITS	Bit to extract from the Status Message
Station_Start	IN	UINT	Station start position
Out_Arry	IN/OUT	ARRAY[*] OF WORD	Word Array the bits will be stored in
ENO	OUT	BOOL	Always High
Activity	OUT	BOOL	Toggles every time a status message is processed
Error_String	OUT	STRING	Text string indication of an error for diagnostic use

## MC\_IP\_CALL\_EXTRACTOR

This function block can be used to get information on a Masters current call.

### MC\_IP\_CALL\_EXTRACTOR Function Block Variables

Name	In/Out	Type	Description
ENX	IN	BOOL	Enable the function block
Status_Message_Call_Inf o	IN	sSTATUS_CALL_INF O	Call Message Information
ENO	OUT	BOOL	Always High
Src_Server_ID	OUT	BYTE	Call Server Source ID
Dest_Node_Type	OUT	eSTATION_TYPE	Call Node Destination Type
Dest_Server_ID	OUT	BYTE	Call Server Destination ID
Dest_Node_ID	OUT	WORD	Call Node Destination ID
InCommo_Bit	OUT	BOOL	In call flag

**Notes:**

**This is the Back Page of the**  
***Tech Works***  
**MC-IP Systems Manual**

**Copyright Tech Works, Inc.**  
**Henderson Nevada**  
**All rights Reserved**