



CI-MSI-22

Microphone / Speaker Interface System Planning & Installation Manual

The Tech Works CI-MSI-22 Microphone Speaker Interface is part of the Collaborative Intercom product group. Designed to take a variety of Audio Intercommunication products and let them talk to each other over the Tech works CI-BUSS.

The CI-MSI-22 consists of five Functional Modules; Two Inputs; The local Microphone/Line Input and the PA-BUSS Input, Two Outputs; a 25 Volt Speaker Output and the PA-BUSS Output, and the CI-BUSS Interface. The Jumper Options determine how these Modules interact and function with each other. The "Standard Configuration" is a Remote (Single Location) for use with an Operator Console. The Power Amplifier, is used for a Procedure Room Speaker while the Microphone Input is used for a boom mounted or hanging Procedure Room Microphone. The PA-OUT, is used as Procedure Room Monitor Output, perhaps for Background Music. The PA-IN, may be used for an additional Microphone. The CI-BUSS may be used with other Interfaces, such as a HSI-41

Initial setup is accomplished with built in level indicator lights and the controls. Once completed, no further adjustments should be required. Integral ALC, Variable Notch Filters, and Speaker Ducking allow for full duplex conversations without feedback.

The CI-MSI-22 can be used in a small Intercom when connected to a single CI-BUSS product or as an addition to larger systems using Headsets, and a variety of CI-BUSS and PA-BUSS devices. The Intercom simply plug together using standard CAT-6 patch cables. When connected to another CI-BUSS unit all headsets, speakers and microphones become part of that system. The CI-MSI-22 provides a level of flexibility and control unmatched in communication.

BENEFITS

- Superior Sound Quality
- Low Cost
- Total Flexibility
- Easy set up
- Simple integration

Associated Equipment

PA-402	Program and Paging Amplifier
CI-HSI-41	Collaborative Intercom Headset Interface
CI-ODC-1	Collaborative Intercom Operator Desk Console

Design Information

Color: Light Gray metal enclosure
Power: 24VDC, 1.5A Power Supply
(Not included)

Weight: 2.6 lbs.

Dimensions: 8.5" W X 6" D X 1.75" H

Architects' and Engineers' Specifications

A Microphone, Speaker Interface must be provided for this project to have hands-free full duplex communication in the Procedure Room. The Microphone, Speaker Interface must be capable of articulate voice pickup from a professional cardioid condenser microphone and clear listening from an industry standard 25 volt speaker without feedback. The system shall include band pass filters, narrow band notch filters and adjustable ducking for tuning the system to the room acoustics while maintaining full duplex communication. The system must include Automatic Level Control and the Collaboration Intercom interface for connection to other Tech Works CI-BUSS devices for a complete and operable system. System connections must be via industry standard CAT-6 patch cords. The Microphone, Speaker Interface shall operate from a separate UL Listed 24 VDC 1 Amp power source.

The Microphone, Speaker Interface shall be
Tech Works Model CI-MSI-22



Tech Works®

"Making Specialized Communication Easy"

Table of Contents

	Page
Front Controls and Indicators	3
Rear Connections	4
Initial Adjustments	5
Notch Filter Setup	5
Configuration Options	7
Universal Microphone/Line Input	8
PA-BUSS Input:	9
PA-BUSS, Monitor/Communications, Output	10
Feedback Prevention, Ducking	11
<i>Ceiling</i> Speaker Output:	12
CI-BUSS, Collaboration Buss	13
CI-MSI-22, Configuration Worksheet	14
Packaging & Mechanical	16
Accessories	17

Figures

Front Panel	3
Rear Panel	4
Simplified Block Diagram	6
Jumper Options	7
Universal Microphone/Line Input	8
PA-BUSS Input Simplified Block Diagram	9
PA-BUSS Connectors	9
PA-BUSS Output Simplified Block Diagram	10
Feedback Prevention, Ducking	11
Speaker Output Simplified Block Diagram	12
CI-BUSS Simplified Block Diagram	13
Packaging & Mechanical	16
Accessories	17

The CI-MSI-22 is Collaboration Intercom Building Block with five Functional Modules:
 Two Inputs; The 'Local' Microphone/Line Input, The PA-BUSS Input
 Two Outputs; The PA-BUSS Monitor/Communications Output, Speaker Amplifier
 CI-BUSS Interface

The “Configuration” ties the Functional Modules Together with Jumpers.
 The “Configuration” also determines how the CI-MSI-22 responds to external Audio, and Control Inputs.
 Different “Configurations” support many applications.

Front Controls and Indicators:

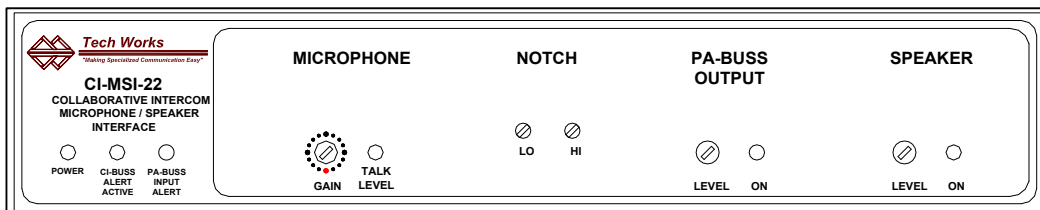

Power indicator: Green, when operating Normally.

CI-BUSS, ALERT Active Indicator: Green, when the *Operator Microphone* is Active.

PA-BUSS Input, ALERT Indicator: Green, when the PA-BUSS Input is Active.

Microphone Gain:

16 Position Rotary Switch, factory set to 8.
 3dB/Step, 45dB Range

Talk Level Indicator:

Off, BUSSES are not receiving the Microphone output.
 Green, Microphone has low input level.
 Green, flashing to Red, Normal Operation, with Local Microphone, and ALC is active.

Notch Filter:

'LO' Band Notch Filter trimpot, 250 to 1000Hz.
 'HI' Band Notch Filter trimpot, 750Hz to 3000Hz .

PA-BUSS Output

Level Control trimpot.
 ON Indicator: Green, when the PA-BUS is Active.

Speaker Output

Level Control trimpot.
 ON Indicator: Green, when the Speaker Amplifier is Active.

NOTE: The Controls are for system setup. They are not User Controls.

Rear Connections:

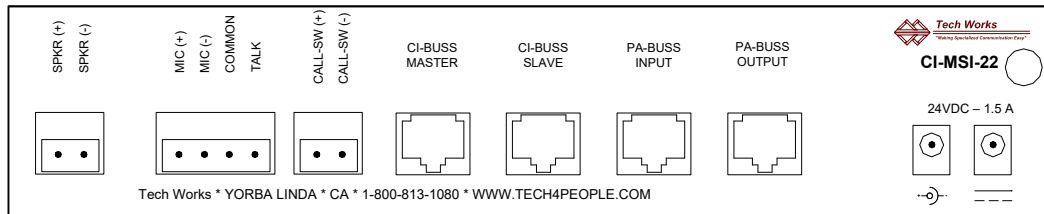

Speaker Output:

Two Position Euro-Style Barrier Strip:

Speaker (+)

Speaker (-)

25-Volts Maximum, 10-Watts Maximum.

Microphone Input:

Four Position Euro-Style Barrier Strip:

Universal Microphone/Line Input (+)

Universal Microphone/Line Input (-)

Shield/Switch Common

Talk Switch (N.O.)

Configured for a Microphone Level Input:

2000 Ohms Balanced

-75dBm or -60dBm (Selectable) minimum input (Balanced) for full rated output.

Selectable Equalization - 3 settings optimized for voice communication.

Selectable Phantom Power (23 Volts, Short Circuit Protected).

Configured for a Line Level Input:

2000 Ohms Balanced, 1000 Ohms Unbalanced.

Balanced input -35dBm to +5dB or -20dBm to +20dB Accommodation range (Selectable).

Un-Balanced Input -30dBm to +10dB or -10dBm to +20dB Accommodation range (Selectable).

Call Switch:

Two Position Euro-Style Barrier Strip:

Call Switch (+), (N.O.)

Call Switch (-)

Call Switch must Float W.R.T. Common.

CI-BUSS, "Master" Connector, RJ-45

CI-BUSS, "Slave" Connector, RJ-45

PA-BUSS, Input Connector, RJ-45, Optionally Powered

PA-BUSS, Output Connector, RJ-45, Always Powered

Maximum available PA-BUSS Power is: 23 Volts @ 350MA

Power Connectors: (Two)

3.5mm Barrel Connectors, 24Volts, 1.5 Amps Maximum, depending on Speaker load.

Chassis, Earth Ground

Hex Nut, The Chassis is connected to Circuit Common through a 1-Meg-Ohm resistor.

Initial Adjustments:

There are both Input and Output Controls with associated Indicators. When the Indicators are green the associated control is enabled. The Audio may be 'Keyed' depending on the Configuration and system setup.
Only attempt adjustments if the associated indicator is lighted green!

The CI-BUSS uses a standard audio level of ~0dBm RMS. The Digital Rotary Switch (3dB/Step) is used to set Microphone Gain. The nominal Microphone gain is ~6dB, or less, into limiting.

Microphone Gain is always setup first. Initially, the Output level controls should be set to minimum (No Output)

Limiter Setup with a Microphone: *Always do this first*

Provide a normal input to the Microphone, or Line input. Insure the Microphone is Keyed, the indicator is Green. Advance the "Microphone Gain", from "0" until the Talk Level indicator just flashes Red. *If this setting is below "2" move the Gain Range Jumper to the "LOW" Position.* Advance the "Microphone Gain" no more than two clicks (6dB into limiting).

Monitor/Communications and Speaker setup: *Assure there is an audio input.*

With normal audio input levels, with Inputs and outputs keyed (Output Indicator Green). Set the Speaker Listening Level. See the PA-BUSS Section for Monitor/Communications Output Adjustments.

Notch Filter Setup: *Do after initial setup*

The factory settings are: LO, fully CCW, HI, Fully CW; the Notch Filters are essentially disabled

Notch Filters can greatly reduce feedback; however they cannot make up for poor acoustic isolation.

There are two distinct primary resonance modes in most installations. One is room resonance; usually one mode is most prevalent, such as floor to ceiling resonance. This frequency is usually on the order of a few hundred cycles. The second mode is the distance of the microphone from a near object. This frequency is much higher near 1000Hz. The CI-MSI-22 incorporates two filters in tandem, one a low Band Filter 250Hz to 1000Hz, and the other a High band Filter 750Hz to 3000Hz.

Adjust the Notch Filters one at a time. Increase the Microphone Gain Control until feedback occurs. Make a rough determination of the frequency (or measure the frequency with a counter).

If the feedback is below ~800Hz, adjust the 'Lo Notch' until feedback ceases. If the feedback is above ~800Hz, adjust the 'Hi Notch' until feedback ceases. (This is a 20-turn pot so it is best to start from one extreme, and slowly turn the pot in the other direction.

Increase the Microphone Gain Control until feedback occurs again, if it is at the same frequency; try finely adjusting the same filter to see if the feedback can be eliminated. If the frequency is different, and in the other range not already tuned, repeat the steps above.

If only one Notch Filter is required, the other filter should be set at the extreme of its range. Fully CCW (lowest frequency) for the LO filter, and fully CW (highest frequency) for the HI filter.

After the Notch Filters are adjusted, redo the initial adjustment above.

Note: Before making any adjustments assure there are audio Inputs and Outputs. All the associated indicators must be lighted green.

Functional Block Diagram (Simplified):

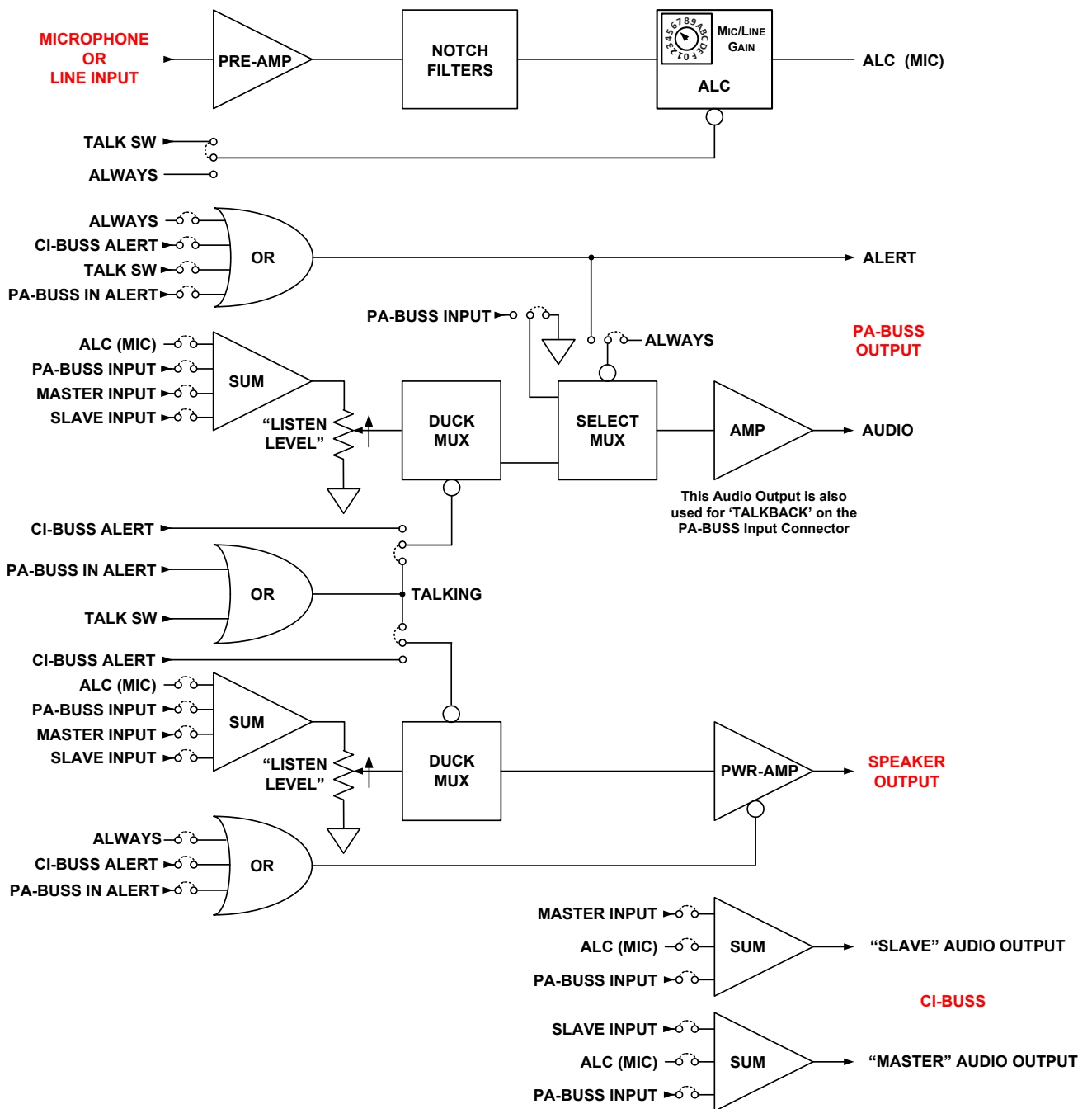

Simplified Block Diagram to illustrate some of the Configuration Jumper Options

Major Component not shown:
Transformers, Opto-Couplers, Audio Buffers

Jumpers not shown:
Microphone or Line Input Options; *see explanations below*
Ducking Levels; *see explanations in the "General Section"*
PA-BUSS Input, Power Pair; *see explanations in the "General Section"*

Configuration Options:

The CI-MSI-22 is designed to accommodate many applications. For most applications the factory default setting is sufficient. For 'special' applications a few jumpers may need to be moved. These Jumpers determine how the CI-MSI-22 interacts with other Components of the System.

Before attempting a Configuration you should review the CI & PA, BUSS sections.

The CI-MSI-22 consists of five Functional Modules:

Two Inputs; Local Microphone/Line Input; PA-BUSS Input

Two Outputs; PA-BUSS Monitor/Communications Output; Speaker Amplifier

CI-BUSS Interface

The Jumper Options determine how these Modules interact and function with each other.

The "Standard Configuration" is a Remote (Single Location) for use with an Operator Console.

This is a Remote (Single Location) for use with an Operator Console.

The Power Amplifier, is used for a Procedure Room *Ceiling* Speaker.

The PA-OUT, is used as Procedure Room Communications.

The PA-IN, may or may not be used for another Microphone.

The CI-BUSS may be used with other Interfaces, such as a HSI-41.

Jumper Options

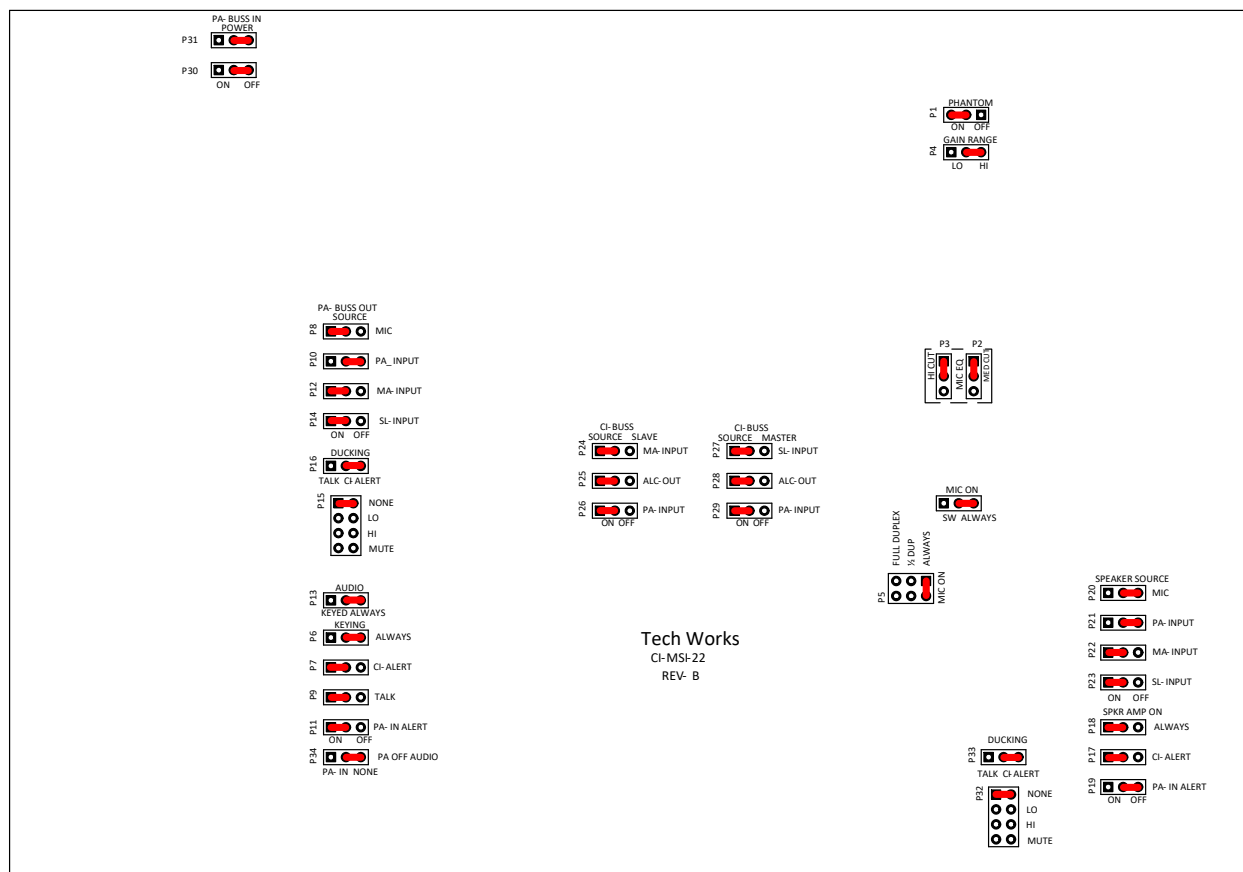

The following is an explanation of the options, using the 'Standard Configuration'.

Universal Microphone/Line Input (Notch Filter not shown):

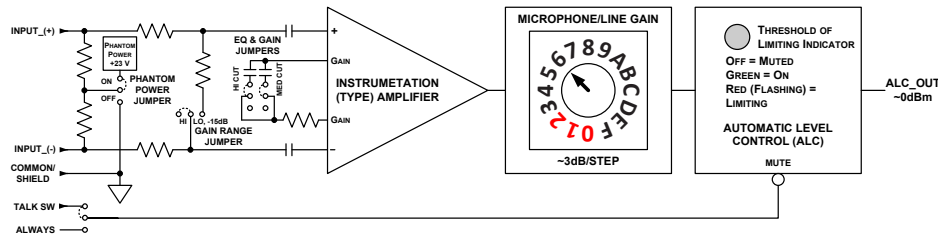

This input can accommodate a wide range Microphone or Line inputs.

The Microphone Sensitivity is adjustable with the 16 Position Rotary Switch, with ~3db/Step for a 45 dB range.

By using the Gain Switch, and Jumper options the total Range is -75dB to +20dB.

The Signal is processed with an ALC, to assure the Output never exceeds 0dBm.

Indicators allow the Microphone Gain to be adjusted to the optimal level.

Phantom Power:

Terminating Resistors referenced to +23Volts, Current limited @ 7MA , ON.
 Terminating Resistors connected to Common, OFF.

Gain Range:

Input Gain reduced 15dB, LO.
 Full Gain, HI.

EQ Jumpers (Two):

Both Jumpers, upper position, lowest frequency Roll-off.
 (Used with most gooseneck and Hanging microphones).

Only MED CUT Jumper Upper Position, Medium frequency Roll-off, used with most flush mounted microphones.

Only HI CUT Jumper Upper Position, Highest frequency Roll-off used with most Speakers used as a microphone.

Both Jumpers Lower Position, (Line Input) ~170Hz Roll-off, Sensitivity reduced to -35dBm input for full Output.

Notes:

*If the Limiting occurs with the Stepped Gain Control on "0", "1" or "2".
 There is insufficient Headroom, use the "LO" Gain Range.*

For a Balanced Line Level Input the LO Gain Position is also used.

The Accommodation Range for full output is ~ -10dBm to +20dBm (With 10dB of Headroom).

The ALC may be enabled, or inactive (Muted).

The ALC passes signals when the Talk Switch is Active. This is selectable:

MIC ON TALK_SW ALWAYS.

PA-BUSS, Monitor/Communications, Output, has many uses:

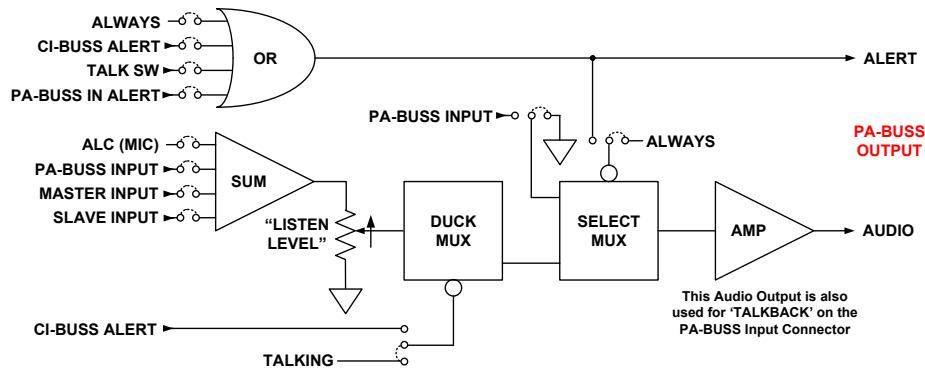

It could be:

- A logging output, for recording the conversation, or just selected individuals.
- A “paging” output to talk to people observing a procedure.
- Used for Patient Communications, to talk to the patient that is undergoing a procedure such as an MRI.

There could be Background Music, which is only interrupted when communications or Paging takes place. For the various applications see the PA-BUSS Section of the main Systems Planning guide.

The PA-BUSS Monitor has several Audio Selection Choices, which are summed:

- Master Connector: ON OFF
- Slave Connector: ON OFF
- PA-BUSS Input: ON OFF
- ALC (Microphone): ON OFF

Each of these selections determines what is sent out of the PA-BUSS Output connector. This could determine what comes out of a speaker, or what is heard by another device connected to the PA-BUSS.

The Audio May be Keyed (See below) or may always be enabled KEYED ALWAYS

The PA-BUSS Monitor ALERT Signal (Keying Signal) is selectable, logical OR’ed

- Talk Switch Active TALK_SW ON OFF
- CI-BUSS is ALERTed CI-BUSS_ALERT ON OFF
- Always (Overrides other selections) ALWAYS ON OFF

The Alert signal determines when other devices connected to the PA-BUSS Output and react to commands from the PA Output. This would include muting of Music or turning on Paging.

The PA-BUSS is always powered, 23 Volts, at a Maximum of 300 Milliamps

This power is made available to run modules connected to the PA-BUSS.

For more details on the PA-BUSS please see the PA-BUSS Section of the main CI & PA-BUSS Systems Planning & Installation Manual.

Feedback Prevention:

Please read the section on "Audio System Setup" in the main CI & PA-BUSS Systems Planning & Installation Manual

Selective Gain Reduction, "Ducking" is used to determine how much to turn down the sound.

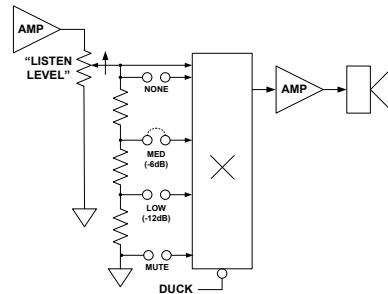

The Monitor/Communications level may be reduced to avoid Feedback, "Ducking".

Ducking is invoked if:

Either Local Mike is Active,	TALKING
CI-BUSS is ALERTed,	ALERT

Ducking Options:

0dB, No Level Reduction,	NONE
-6dB, Moderate Level Reduction,	LO
-12dB, High Level Reduction,	MED
MUTE, No Audio Output,	MUTE

Ducking is available for both the PA-BUSS Output and the built in Amplifier Output for a local Ceiling Speaker. There are two separate sets of jumpers, one for the PA-Buss and one for the Amplifier.

Notch Filter

Notch Filtering the Microphone reduces acoustic room resonance peaking.

Rooms without acoustic treatment have significant resonances. This 'peaking' has the effect of greatly increasing gain at these resonance frequencies.

This is significant with directional hanging microphones; floor to ceiling resonances are magnified. A notch filter can be used to reduce this peaking, without adversely affecting communications.

Some Tech Works products include two variable notch filters to control these resonant frequencies. One is a low audio band, variable center (or movable) notch filter, and the other is a hi audio band, variable notch filter. Each filter includes a 20 turn precision potentiometer which allows the installer to adjust the filter until a high frequency feedback is eliminated and then a lower frequency feedback is eliminated.

By eliminating the first two primary ring modes or resonant frequencies in a room the gain before feedback can be increased by as much as 6-12 dB or 4 times the power to the listener.

Ceiling Speaker Output:

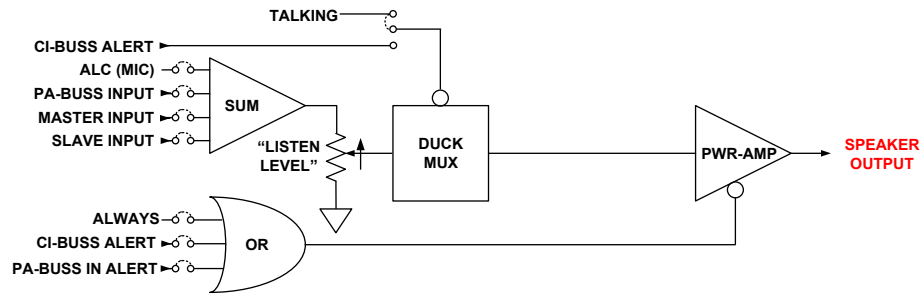

This would usually be one or more Ceiling Speakers, in a Procedure Room, or Operating Room, or it could be for the Operator Speaker, or other uses.

The Feedback reduction, "Ducking" is set to a modest level, and is keyed by the Talk Switch.

There are several Audio Selection Choices, which are summed:

Microphone:	ON	OFF
PA-BUSS Input:	ON	OFF
Master Connector:	ON	OFF
Slave Connector (Usually the Operator Microphone):	ON	OFF

The Speaker level may be reduced to avoid Feedback, "Ducking".

Ducking is invoked if:

Either Local Mike is Active,	TALKING
CI-BUSS is ALERTed,	ALERT

Ducking Options: Selective listening level reduction:

0dB, No Level Reduction,	NONE
-6dB, Moderate Level Reduction,	LO
-12dB, High Level Reduction,	MED
MUTE, No Audio Output,	MUTE

The Speaker Amplifier is enabled when, logical OR'ed:

Always, overrides other choices,	ON	OFF
CI-BUSS is ALERTed,	ON	OFF
PA-Input is ALERTed,	ON	OFF

CI-BUSS, the Collaboration Buss, allows chaining of several Units:

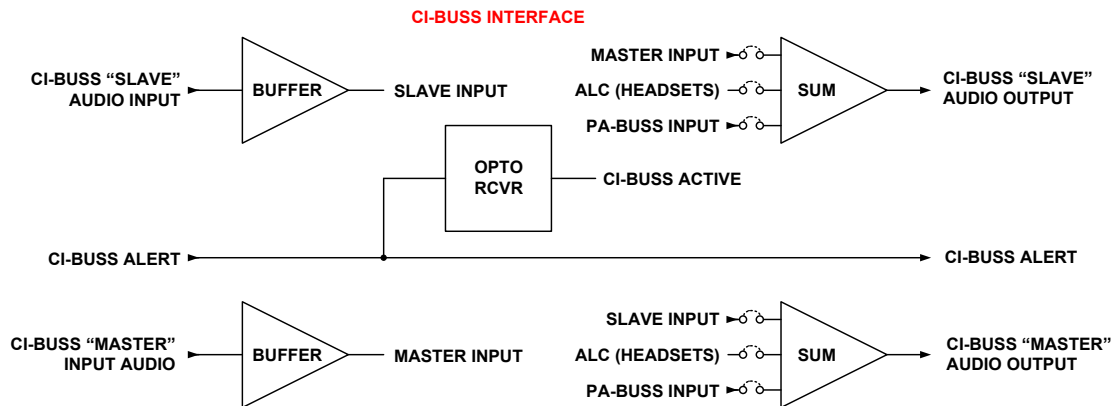

In the Standard Configuration **all the users** of the CI-BUSS **talk and listen to each other**. However there may be situations where some users may only listen, or only talk.

There are two Collaboration Buss connectors on the MSI-22. One is Labeled "Master" and the other is labeled "Slave". The Jumpers illustrated above determine what is sent out of the SLAVE connector or the MASTER connector.

The Jumper Selections allow selective Collaboration or communication between units on the chain. So just because something comes into the Slave Connector, does not mean that it has to go out of the Master connector to the other devices. By moving the Jumpers the installer can determine what comes in and what goes out of each connector independently. Changing one selection does not affect another.

These settings do not affect the Monitor/Communications Output, PA-BUSS.

Slave IC-BUSS Connector, BUSS Output, Summed:

Master Connector:	ON OFF
Headsets:	ON OFF

Master IC-BUSS Connector, BUSS Output, Summed:

Slave Connector:	ON OFF
Headsets:	ON OFF

The Call Pair is a "Party Line" passing through to all the Blocks forming a Group. The Operator Console Responds to a *Switch Closure* by initiating a Calling Sequence. All Switches must be floating, or isolated with Opto-Couplers.

The Alert Pair is a "Party Line" passing through to all the Blocks forming a Group. The Operator Console sends a signal to all the Other Blocks, *such as my Microphone is On*. The other Blocks may be configured to "Respond" in an appropriate manner. Responder Blocks, are electrically isolated, with Opto-couplers.

For more details on the CI-BUSS please see the CI-BUSS Section of the main Systems Planning guide.

CI-MSI-22, Configuration Worksheet:
"Standard Configuration" shown in Red

Universal Microphone or Line Input			Phantom Powered hanging Microphone
Phantom Power	ON	OFF	
Gain Range	LOW	HIGH	
HI EQ	IN	OUT	
LO EQ	IN	OUT	
Mike On	ALWAYS	TALK SWITCH	
PA-BUSS Input, Power Jumpers (2)			PA-BUSS Input is not Powered If a MHI-11 is used, the PA-INPUT will need to be Powered
Power	ON	OFF	
PA-BUSS Output			PA-BUSS Output is Configured for a Ceiling Speaker
Audio Sources, Summed			
Microphone	ON	OFF	
PA-BUSS Input	ON	OFF	
Master IC-BUSS Connector, <i>Could be Headsets, etc</i>			
Slave IC-BUSS Connector, <i>Could be Operator Microphone</i>			
Duck when:			
Only when the CI-BUSS is ALERTed, Only when Talk Switch is Active			
Ducking level			
0dB, NONE -6dB, MEDIUM -12dB, LOW Muted, MUTED			
Audio Outputted (See Below)			
Always PA-BUSS Output Is ALERTed			
Audio Output is ALERTed when: OR'ed			
Always, other Jumpers Ignored	ON	OFF	
CI-BUSS is ALERTed	ON	OFF	
Talk Switch is Active	ON	OFF	
PA-BUSS Input Active	ON	OFF	
Audio Output when 'Off'			
PA-BUSS Audio Input, or nothing,	PA IN	NONE	
Speaker AMPLIFIER			Ceiling Speaker

Audio Sources, Summed	
Microphone	ON OFF
PA-BUSS Input	ON OFF
Master IC-BUSS Connector, <i>Could be Headsets, etc</i>	
<i>Slave IC-BUSS Connector, Could be Operator Microphone</i>	
Duck when:	
Only when the CI-BUSS is ALERTed	
Only when Talk Switch is Active	
Ducking level	
0dB, NONE	
-6dB, MEDIUM	
-12dB, LOW	
Muted, MUTED	
The Amplifier is enabled when: OR'ed	
Always, other Jumpers Ignored	ON OFF
CI-BUSS is ALERTed	ON OFF
PA-BUSS Input Active	ON OFF

Ducks when the Talk Switch is Active

Modest Speaker level Reduction

Keyed when *Operator* is talking to the Procedure Room

CI-BUSS passes all

Slave IC-Buss Output, Summed	
Master Connector:	ON or OFF
Microphone:	ON or OFF
PA-BUSS Input,	ON or OFF
Master IC-BUSS Output, Summed	
Slave Connector:	ON or OFF
Microphone:	ON or OFF
PA-BUSS Input,	ON or OFF

Packaging & Mechanical:

1U, Half Rack, 8.60" X 1.75" X 6.00"

Mounting Options: Table-Top; Under Counter; Rack
Modular aluminum and steel enclosure

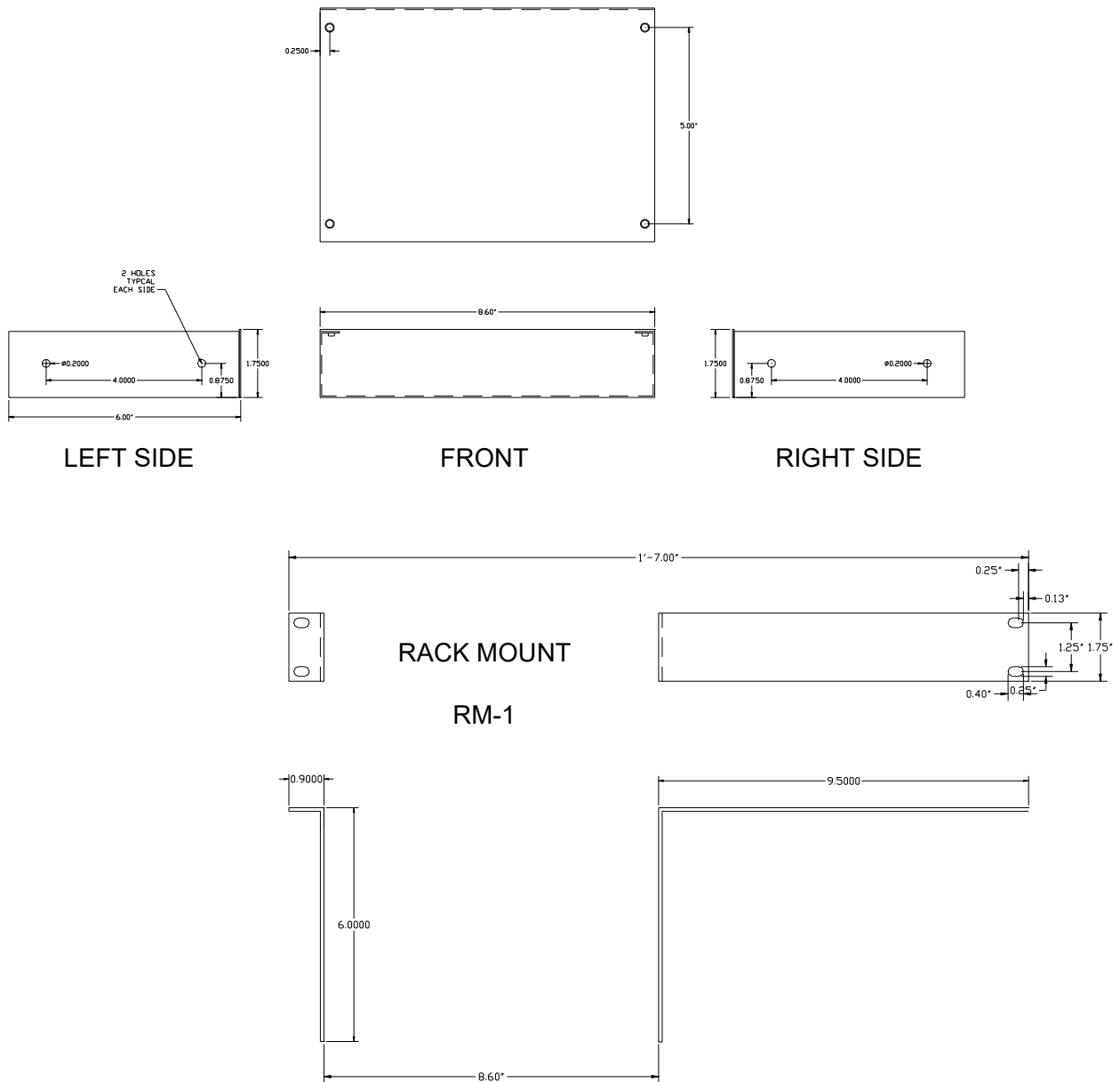

Accessories



CS-540 Wireless Headset - When the user requires mobility, privacy, and quality the CS-540 does it all in a light weight rechargeable package with an integral over the ear mounting band.



PRO-45 Hanging Microphone - In the procedure room area such as an operating table the PRO 45 is a high quality condenser microphone with cardioid pattern for excellent signal to noise and 25' cable included for easy connection.



PRO-47T -PLUS - Microphone with a DESK STAND BASE and Two Switches. This is the perfect solution for the Cath Lab operator location. It is an attractive professional assembly complete with a Blue "Talk" and an Amber "Listen" switch to allow complete control of communication flow.



PRO-42 - is a Wide-Range Miniature Condenser Microphone with a hemi-cardioid polar pattern. It was designed for surface-mounted applications in high-quality sound reinforcement and other demanding sound pickup situations like procedure room boom arms.



HM-1 - Hidden Microphone - The HM-1 is an Omni-Directional Condenser Microphone with an electronically balanced preamp designed for interview pick up. This is a complete assembly including a 1-gang face plate and mounting hardware.



FS-1-ODC – Foot Switch for the Operator Desk Console allows the operator to use the microphone as a Push-To-Talk unit without tying up their hands to use a button.



FS-1-PLUS - Call / Control Switches - The FS-1-PLUS which includes a 15 foot cable with connectors and wall plate. Both offer a variety of hands free call in and control options.



System 21 Flush Speaker System- is a complete cost, effective, assembly that includes a high-quality 8" loudspeaker, 25V transformer and perforated steel grill. This unit is made to "Blind Mount" in to hard ceilings.



System 5 Ceiling Mount Speaker System- This is a complete assembly including a back box and mounting hardware. The System 5 comes complete with a 25 volt transformer or is available as the System 5-8 in 8 Ohm for Music playback.

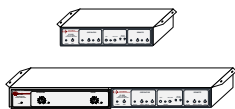

WM Wall Or Under Counter Mount – All Tech Works Universal Box products are available with 1" metal tabs on each side of the unit for easy attachment to either a wall or the underside of a counter. Also available in a side by side WM2 .



RM Rack Mount - All Tech Works Universal Box products can be rack mounted as either a single unit, dual units (side by side), or as companions with accessories like the PA-402 Amplifier. The rack mount is 1 rack unit (1-7/8") High by EIA 19" Wide.



CAT6-* Computer Patch Cables, for plugging CI and PA Buss modules together to make a system. Available in a variety of lengths from 1 foot to 50 feet.

PC-* Power Cords, for sharing system power between CI and PA Buss modules together to make a system. Available in a variety of lengths from 1 foot to 50 feet.