

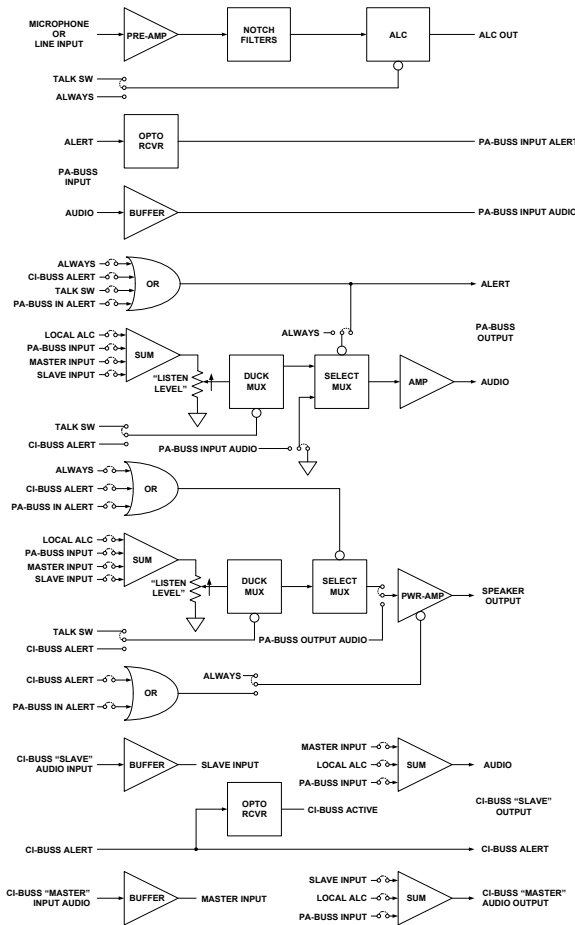

CI-MSI-22

QUICK REFERENCE GUIDE

The MSI-22 is a Microphone and Speaker Interface for our Collaborative Intercom family of products. The can be two Microphones (One from the Microphone Input; one from the PA-BUSS Input using a PA-MI-1) Two Speaker outputs (One from the Speaker Output; one from the PA-BUSS output using a AS-1 or PA-402)



Basic Microphone / Speaker Interface Block Diagram (Transformers not shown for clarity)

Each input can be routed to an output or all outputs by placing routing jumpers inside the unit as desired. The CI-BUSS interface performs the same function for additional units. The Microphone is processed with ALC to be of constant level and passed to other Units in both directions as selected. The ALC has an indicator for the Threshold of Limiting. This indicator also serves as a setup indicator for adjusting the Microphone level.



Tech Works®

"Making Specialized Communication Easy"

Front Controls and Indicators:

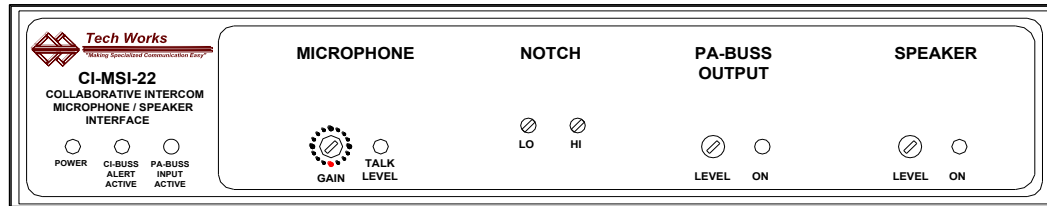

Power indicator: Green, when operating Normally

CI-BUSS, ALERT Active Indicator: Green, when the *Operator Microphone* is Active

PA-BUSS Input, ALERT Indicator: Green, when the PA-BUSS Input is Active

Microphone Gain: 16 Position Rotary Switch, factory set to 8, 3dB/Step, 45dB Range

Talk Level Indicator: Green, low input level; Green, flashing to Red, Normal Operation, with Local Microphone, and ALC is active

Notch Filter: 'LO' Band Notch Filter trimpot, 250 to 1000Hz; 'HI' Band Notch Filter trimpot, 750Hz to 3000Hz

PA-BUSS Output: Level Control trimpot; ON Indicator: Green, when the PA-BUS is ON

Speaker Output: Level Control trimpot; ON Indicator: Green, when the Speaker Amplifier is ON

NOTE: The Microphone Gain control is for setup; once set, it should not be touched by the User

Rear Connections:

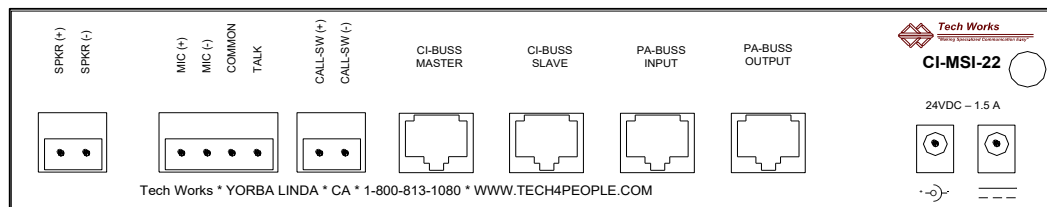

Speaker Output: 25-Volts Maximum, 10-Watts Maximum; Two Position Euro-Style Barrier Strip: Speaker (+/-)

Microphone Input: Four Position Euro-Style Barrier Strip: Universal Microphone/Line Input (+/-); Shield/Switch Common; Talk Switch (N.O.)

Selectable Equalization - 3 settings optimized for voice communication

Selectable Phantom Power (22 Volts, Short Circuit Protected)

Configured for a Microphone Level Input: 2000 Ohms Balanced, -75dBm or -60dBm (Selectable) minimum input (Balanced) for full rated output

Configured for a Line Level Input: 2000 Ohms Balanced, 1000 Ohms Unbalanced, Balanced input - 35dBm to +5dB or -20dBm to +20dB Accommodation range (Selectable), Un-Balanced Input -30dBm to +10dB or -10dBm to +20dB Accommodation range (Selectable)

Call Switch: Two Position Euro-Style Barrier Strip: Call Switch (+/-), (N.O.)
Call Switch must Float W.R.T. Common

CI-BUSS, "Master" Connector, RJ-45

CI-BUSS, "Slave" Connector, RJ-45

PA-BUSS, Input Connector, RJ-45, Optionally Powered for a CI-MI-1

PA-BUSS, Output Connector, RJ-45, Always Powered for an AS-1, 23 Volts @ 350MA Maximum

Power Connectors: (Two) - 3.5mm Barrel Connectors

Chassis: Knurled nut, Earth Ground

The Chassis is connected to Circuit Common through a 1-Meg-Ohm resistor

Initial Adjustments:

There are both **Input and Output Controls with associated Indicators**

When the Indicators are green the associated control is enabled

The Audio may be 'Keyed' depending on the Configuration and system setup

Only attempt adjustments if the associated indicator is lighted green!

The CI-BUSS uses a standard audio level of ~0dBm RMS

The Digital Rotary Switch (3dB/Step) is used to set Microphone Gain

The nominal Microphone gain is ~6dB, or less, into limiting

Microphone Gain is always setup first

Initially, the Output level controls should be set to minimum (No Output)

Limiter Setup with a Microphone:

Always do first

Provide a normal input to the Microphone, or Line input

Insure the Microphone is Keyed, the indicator is Green

Advance the "Microphone Gain", from "0" until the Talk Level indicator just flashes red

Advance the "Microphone Gain" no more than two clicks (6dB into limiting)

Monitor/Communications and Speaker setup:

Assure there is an audio input

With normal audio input levels, with Inputs and outputs keyed (Output Indicator Green)

Set the Speaker Listening Level

See the PA-BUSS Section for Monitor/Communications Output Adjustments

Notch Filter Setup: Do after initial setup

The factory settings are: LO, fully CCW, HI, Fully CW; the Notch Filters are essentially disabled

Notch Filters can greatly reduce feedback; however they cannot make up for poor acoustic isolation

There are two distinct primary resonance modes in most installations. One is room resonance; one mode is most prevalent, such as floor to ceiling resonance. This frequency is usually on the order of a few hundred cycles. The second mode is the distance of the microphone from a near object. This frequency is much higher near 1000Hz. The MSI-22 incorporates two filters in tandem, one a low Band Filter 250Hz to 1000Hz, and the other a High band Filter 750Hz to 3000Hz

Adjust the Notch Filters one at a time. Increase the Microphone Gain Control until feedback occurs.

Make a rough determination of the frequency (or measure the frequency with a counter).

If the feedback is below ~800Hz, adjust the 'Lo Notch' until feedback ceases. If the feedback is above ~800Hz, adjust the 'Hi Notch' until feedback ceases. (This is a 20-turn pot so it is best to start from one extreme, and slowly turn the pot in the other direction

Increase the Microphone Gain Control until feedback occurs again, if it is at the same frequency; try finely adjusting the same filter to see if the feedback can be eliminated. If the frequency is different, and in the other range not already tuned, repeat the steps above

If only one Notch Filter is required, the other filter should be set at the extreme of its range.

Fully CCW (lowest frequency) for the LO filter, and fully CW (highest frequency) for the HI filter.

After the Notch Filters are adjusted, redo the initial adjustment above

Note:

Before making any adjustments assure there are audio Inputs and Outputs

All the associated indicators must be lighted green

Configuration Options:

The MSI-22 is designed to accommodate many applications. **For most applications the factory default setting is sufficient.** For 'special' applications a few jumpers may need to be moved. These Jumpers determine how the MSI-22 interacts with other Components of the System

Before attempting a Configuration you should review the "BUSS Systems Guide" CI & PA, BUSS sections

The **MSI-22 consists of five Functional Modules:**

Two Inputs; Local Microphone/Line Input; PA-BUSS Input

Two Outputs; PA-BUSS Monitor/Communications Output; Speaker Amplifier

CI-BUSS Interface

The **Jumper Options determine how these Modules interact and function with each other**

The "Standard Configuration" is a Remote (Single Location) for use with an Operator Console

This is a Remote (Single Location) for use with an Operator Console, CI-ODC

The Power Amplifier, is used for a Procedure Room *Ceiling* Speaker

The PA-OUT, is used as Procedure Room Communications

The PA-IN, may or may not be used for another Microphone

The CI-BUSS may be used with other Interfaces, such as a CI-HSI-41

Jumper Options

